

Investigation on thermo-mechanical behavior of shape memory alloy actuator

MILENA KURZAWA, DOROTA STACHOWIAK

*Institute of Electrical Engineering and Electronics
Department of Mechatronics and Electrical Machines
Poznan University of Technology
Piotrowo 3A, 60-965 Poznań, Poland
e-mail: dorota.stachowiak@put.poznan.pl*

(Received: 30.09.2016, revised: 19.02.2017)

Abstract: The paper presents the design procedure and elaborated software for designing calculation of the shape memory alloy (SMA) actuator. The thermo-mechanical behavior of a linear SMA actuator has been studied. The experimental set-up was especially designed to perform the thermo-mechanical characterization of SMA wires. The stroke (s) – temperature (T) hysteresis characteristics have been determined. The cycle of heating and cooling has been performed under a constant load. The model for the SMA actuator $s - T$ behavior has been proposed and successfully implemented. The selected results and conclusions have been presented. The concept proposal of the linear actuator using the SMA wire has been given.

Key words: shape memory alloys, linear actuator, hysteresis, SMA wire

1. Introduction

The shape memory alloys (SMAs) are functional materials, which can be applied in many applications like the linear actuators due to their large strain recovery, high stiffness and strength [1-5]. The SMA materials have the ability to change their shape depending on the transformation temperatures. In this type of material two crystalline structures can be distinguished: (a) martensite (M) which is thermodynamically stable at a lower temperature and (b) austenite (A), which is the parent phase stable at a higher temperature. The SMA materials in the martensite phase have the crystal structure with a simple symmetry, such as tetragonal, rhombohedral, orthorhombic, monoclinic or triclinic depending on the composition of the alloy, whereas in the austenite phase they are more symmetrical, usually based on a cubic lattice [1, 2]. SMAs are characterized by four temperatures, i.e. the start and finish transformation temperatures: M_s , M_f (martensite start and finish) and A_s , A_f (austenite start and finish).

The behavior of SMA materials (e.g. nickel-titanium metallic alloys, so called Nitinol) is shown in Fig. 1. SMAs have two unique properties: Shape memory effect (SME) and superelasticity (SE) [1, 6, 7]. The SME refers to the phenomenon that SMAs return back to their predetermined shapes upon heating. The SE also known as pseudoelasticity refers to the phenomenon that SMAs can undergo a large amount of inelastic deformations and recover their shapes after unloading [1, 3]. These unique properties are the result of reversible phase transformations of SMAs. The SME is easily found at the martensite phase, which mostly appears at a low temperature. Conversely, the SE is easily detected at the austenite phase, which is stable at a high temperature [1, 3, 7]. When SMAs in martensite are subject to external stress, they deform through a so-called detwinning mechanism, which transforms different martensite variations to the particular one variation that can accommodate the maximum elongation. Due to its parallelogram structure, the martensite phase is weak and can be easily deformed. On the other hand, the austenite phase has only one possible orientation and shows relatively strong resistance to external stress [1, 3, 7].

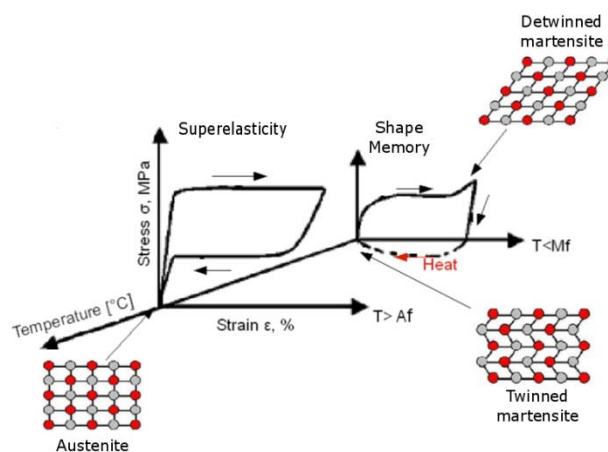

Fig. 1. The behavior of superelasticity and the shape memory effect in the SMA materials according to the phase transformation

The paper deals with the thermo-mechanical behavior of the linear SMA actuator. Nitinol (Ni-Ti) is the material used for the studied SMA wire. The goals of the paper are the discussion of the thermo-mechanical properties of Nitinol material and the proposal of a concept of the linear actuator using the Nitinol wire. The SMA wire is the most commonly applied form for these actuators because of its ease of use and convenient electrical activation.

2. The linear SMA actuator

The design strategy for an actuator based on shape memory wire is to clearly define the appropriate requirements [1, 6, 7]. The SMA wire actuator has the following design parameters: wire diameter, high and low temperature length, low temperature stress and reset force

(high and low temperatures denoted the temperature at an austenite phase and martensite phase, respectively). The wire diameter can be calculated by the following formula:

$$d = \sqrt{\frac{4F}{\pi\sigma_h}} \text{ [mm]}, \quad (1)$$

where: F is the required force in [N], and σ_h is the maximum design stress at a high temperature, in [MPa].

The high temperature length can be obtained from:

$$L_h = \frac{s(1 + \varepsilon_h)}{\varepsilon_l - \varepsilon_h} \text{ [mm]}. \quad (2)$$

In the above formula, s is the stroke in [mm]. Stroke is the difference between the length for the low and high operating temperatures. ε_l is the low temperature strain, and ε_h is the high temperature strain. The high temperature strain described as the ratio of σ_h to the value of Young's modulus of material at a high temperature (E_h), in [MPa].

$$\varepsilon_h = \frac{\sigma_h}{E_h} \text{ [-]}. \quad (3)$$

The low temperature length is given by the formula:

$$L_l = L_h + s \text{ [mm]}. \quad (4)$$

The low temperature stress is defined as the product of ε_l and E_l where E_l is the value of Young's modulus for the material at a low temperature, in [MPa]

$$\sigma_l = \varepsilon_l \cdot E_l \text{ [MPa]}. \quad (5)$$

The reset force can be calculated as follows:

$$F_r = \sigma_l \cdot \frac{\pi \cdot d^2}{4} \text{ [N]}. \quad (6)$$

On the basis of the presented algorithm the own software was developed in Microsoft Visual Studio C# for Windows. The screenshot of the calculator form is shown in Fig. 2.

The user of software can enter the initial data, such as for example stroke and required force. The results of calculation are presented in the group box – Calculations. The software user can find the calculated values of the main properties of shape memory alloy wire actuator, e.g. wire diameter, high and low temperature length.

3. Thermo-mechanical behavior of SMA wire

3.1. Experimental setup

The application of SMA wire as an active element of an actuator is only possible when the thermo-mechanical characterization under various operating conditions are known. Therefore,

the authors elaborated on the special experimental setup for the investigation of the SMA wire properties. The view and schematic block diagram of the elaborated experimental setup have been shown in Fig. 3. The changes of the wire length have been measured by the Potentiometric Linear Transducer (PLT) displacement sensor, which has been placed in series to the SMA wire.

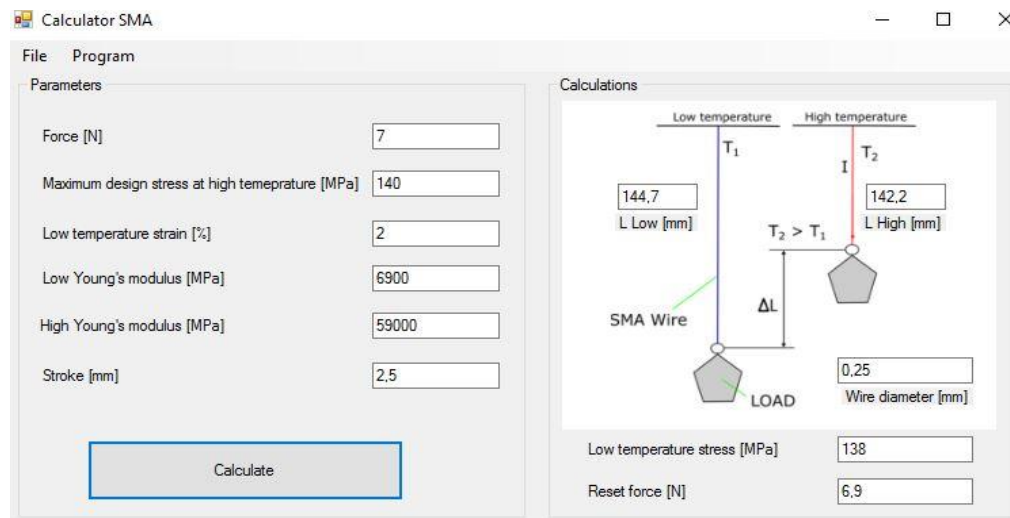

Fig. 2. The screenshot of calculator form

The power supply QPX600DP (80 V, 50 A) was chosen to the linear SMA actuator, which allows for stabilization of the value of current (I) as well as voltage (U). The Joule-heating of the wire and its subsequent contraction are produced by a current that flows through the wire. Both values of U and I are measurable in real-time. Three thermocouples (K-type) have been used for the measurement of the wire temperature.

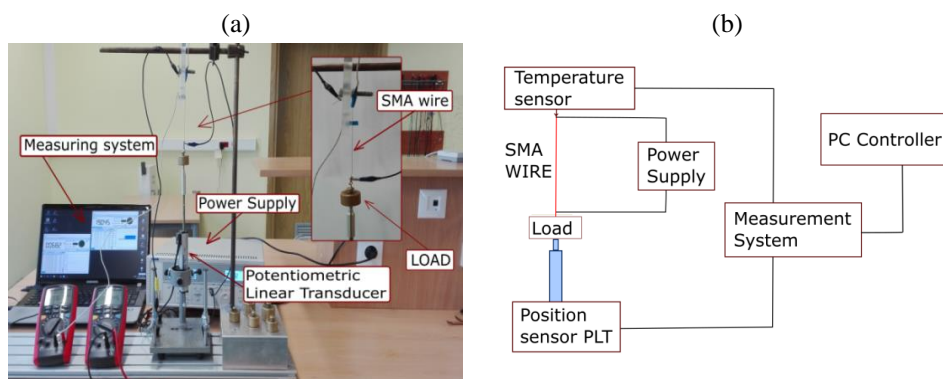

Fig. 3. The experimental setup: a) view, b) block diagram

3.2. Heat transfer model of transformation temperature

The SMA wire temperature can be estimated from the unidirectional heat transfer equation for electrical heating and free convection [7-9]. The SMA heat transfer model has been formulated to describe the rate of temperature change due to a change in voltage of the wire and the convective heat loss to the environment. This model can be defined by the first-order dynamic equation by

$$m_w c_p \frac{dT}{dt} = \frac{U^2}{R} - h_c A_w (T - T_a), \quad (7)$$

where: U is the voltage, R is the SMA wire resistance per unit length, c_p is the specific heat, m_w is the SMA wire mass per unit length, A_w is the circumferential area of the SMA wire, T_a is the ambient temperature, T is the SMA wire temperature, h_c is the heat convection coefficient. The coefficient h_c is approximated by a second order polynomial of the temperature to improve the heat transfer model, $h_c = h_0 + h_2 T^2$ [9].

The heat transfer expression (7) assumes that the problem is one-dimensional, the load applied to the wire is constant, the radiation effects are negligible compared with convection effects of heat transfer, volume and area changes are negligible, the ambient temperature is constant.

The SMA materials are very attractive as thermo-mechanical actuators for applications in robotics [1, 3, 6]. The modeling, design, and optimization of an SMA actuator, is strongly dependent on the knowledge of hysteresis that can mathematically describe the stroke-temperature characteristics. Hysteresis modeling has been studied extensively in the literature [7, 10-12]. In this paper, a model adapted from the limiting loop proximity hysteresis has been used. The limiting loop proximity hysteresis model was originally developed for magnetic hysteresis [11]. The stroke – temperature hysteresis can be obtained from:

$$s(T) = \frac{H_h}{\pi} \left[\arctan \left(\beta \left(\delta \frac{H_w}{2} + T_c - T \right) \right) + \frac{\pi}{2} \right], \quad (8)$$

where: $s(T)$ is the stroke, H_h is the hysteresis height, H_w is the hysteresis width, β is related with $d\varepsilon/dT$ at T_c , T_c is the critical temperature at the center of the hysteresis curve, δ is operator defined as 1 or -1 .

The model is simulated in MATLAB/Simulink environment. The block diagram of heat transfer and stroke – temperature hysteresis model have been shown in the Fig. 4. The elaborated model has been divided in two subsystems representing the heat transfer model and hysteresis model. The first subsystem has been described by Equation (7) whereas the second one by Equation (8). The hysteresis model has been expressed in the form of an algebraic equation which is computationally simple to implement. The parameters of this model have been determined experimentally from experimental data with regard to $s - T$ loops.

The elaborated model allows for taking into account the several different ways of voltage supply of SMA actuator, e.g. DC voltage, linearly increase voltage or the voltage waveform created by the user. The model has the potential to be applied for control purposes in active structures.

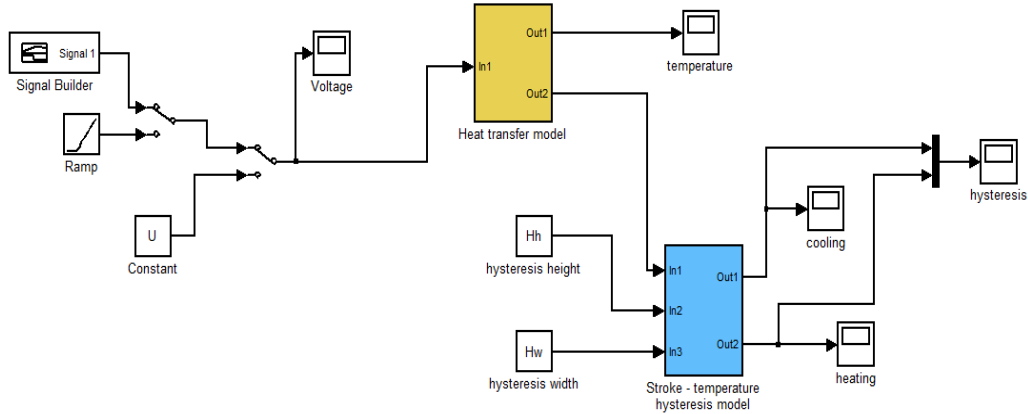

3.3. Selected results

In order to obtain the thermo-mechanical properties and parameters of an SMA wire, an experimental setup has been carried out. The SMA wire of ‘Flexinol LT’ type has been considered, for which the diameter was 0.25 mm and the length was 140 mm. The thermal properties of NiTi, directly extracted from the manufacturer’s data sheets [13]. The rest of the parameters needed for simulation can either be calculated or easily measured through simple experiments.

The temperature of the SMA wire has been experimentally measured and evaluated with computed temperature by a heat transfer model using Equation (7). The SMA wire has been heated by a rapidly increasing current (see Fig. 5a). The waveforms of temperature and stroke of the SMA wire registered during the heating and cooling cycle have been given in Fig. 5b. The SMA wire has been heated by a slowly increasing current. In the cooling cycle the current has been slowly decreased under natural air convection.

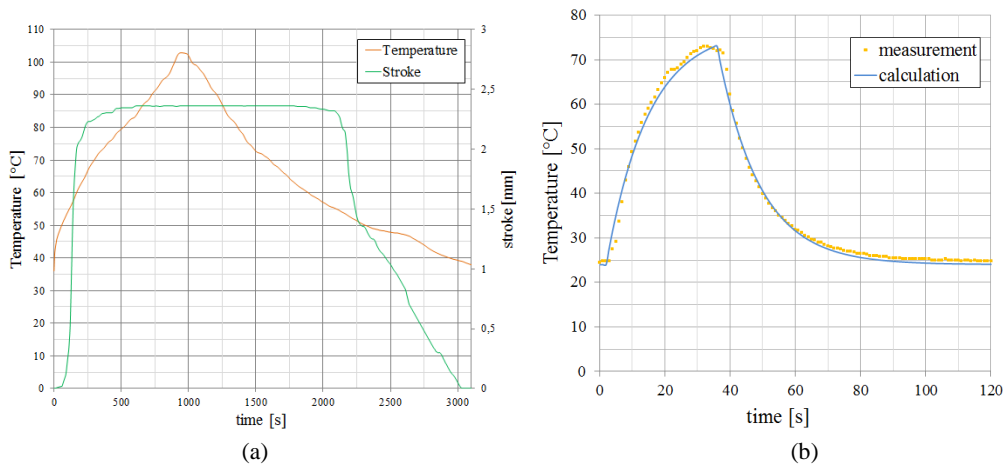

Fig. 5. (a) The measured and calculated temperature of the SMA wire, (b) the temperature and stroke of the SMA wire registered during the heating and cooling cycle

Fig. 6 shows the stroke versus temperature hysteresis loops. The SMA wire elongation and shortening are induced both mechanically and thermally. The experiments are carried out at different loads to investigate its behavior. The stroke – temperature hysteresis loops shown in Fig. 6 have been also calculated using Equation (8) and the $s - T$ hysteresis model (see Fig. 4). The parameters of this model were determined experimentally on the basis of the measured data. The obtained results can be considered satisfactory.

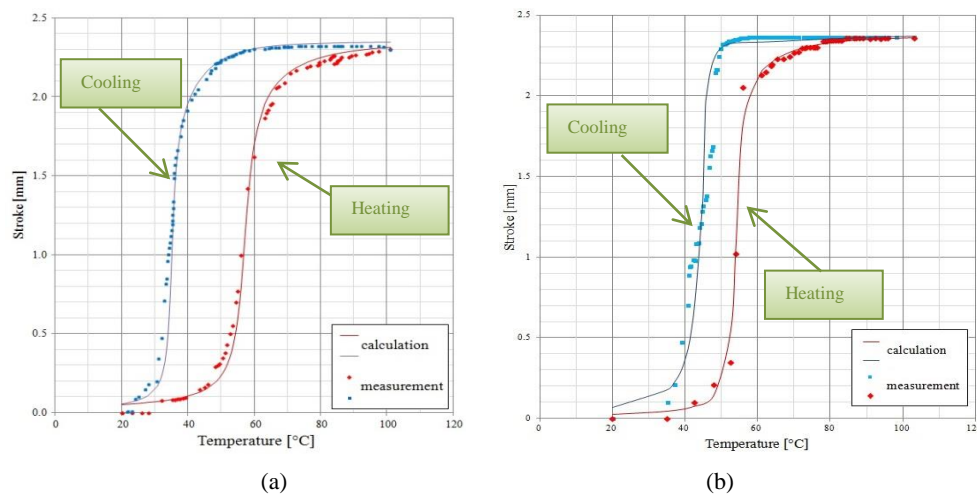

Fig. 6. Stroke – temperature hysteresis at applied load: (a) $Q = 0.1$ kg and (b) $Q = 0.2$ kg

It can be observed that by increasing the applied load the width of the hysteresis loop has been changed. This behavior is typical of the SMA's and corresponds to an increase of transformation temperatures as a function of the mechanical loading.

4. The prototype of the linear SMA actuator

There are a few different configurations of the SMA wire (see, Fig. 7). If it is loaded by a spring or weight, then the strain is small (3-4%) but when the SMA actuator is equipped with a biasing spring, the deformation is higher (see, Fig. 7). Because of the highest displacement, the solution with a biasing spring has been chosen.

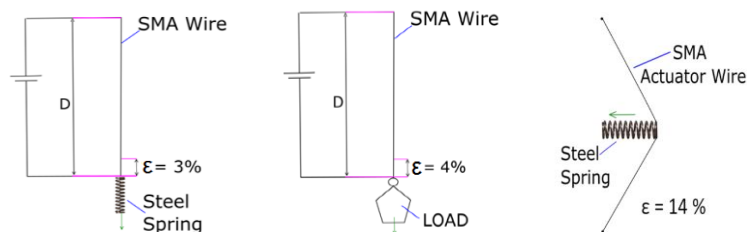

Fig. 7. The typical configurations of the SMA wire

The required force and current value for a constant load have been analyzed and the most efficient wire diameter has been calculated using the elaborated software (see, Fig. 2). Finally, the prototype of the SMA Wire Linear Actuator has been fabricated as per the design concept.

The designed linear SMA actuator with the control circuit has been shown in Fig. 8. The power source had variable current settings, allowing the SMA wire to be activated using the direct current of a constant magnitude. The direct current was turned on and off using an Arduino microprocessor and a transistor. The transistor's base was initially turned to high, allowing the direct current to activate a martensite-austenite transformation in an SMA actuator. Taking the data from the temperature sensor, the microprocessor determined when the transformation was complete, upon which the microprocessor turned the transistor to low, allowing the SMA wire to cool back to its martensite form.

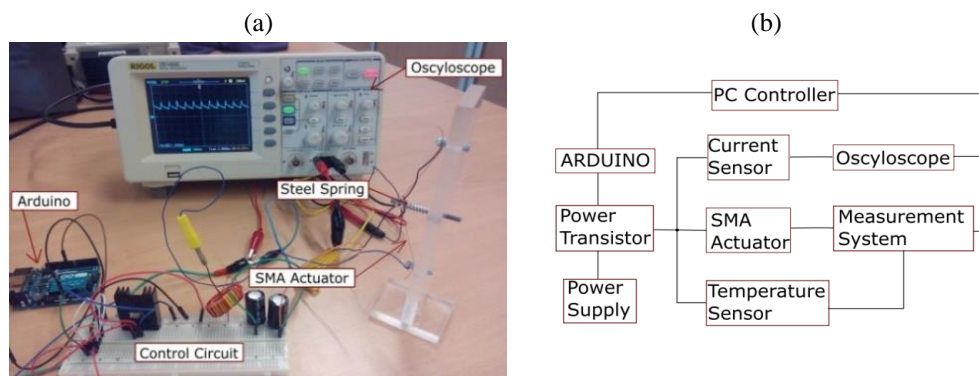

Fig. 8. The SMA actuator setup: a) view; b) block diagram

Preliminary tests of the linear SMA actuator have been performed in order to prove its functionality. Selected field distributions obtained from the thermal camera have been shown in Fig. 9. The thermal camera Flir Exx has been used. It has a resolution of 240×180 pixels and can record pictures up to 60 Hz.

The designed linear SMA actuator can be applied as a thermal circuit breaker or as a main part of SMA actuated self-locking devices. The SMA actuator can be activated in two ways: by electrical or thermal activation.

5. Summary

The results of the investigation of the thermos-mechanical behavior of the SMA actuator have been presented and discussed. The experimental setup has especially been designed to perform direct electrical heating and cooling of the SMA wire by the Joule effect. This apparatus has allowed measurements of displacement as a function of the temperature of samples loaded by constant load. A mathematical model has been developed. The model allows for the

determination of the heating and cooling curve of shape memory material, and the mapping of many characteristics as a function of temperature. The elaborated model has the potential to be applied for control purposes in smart structures.

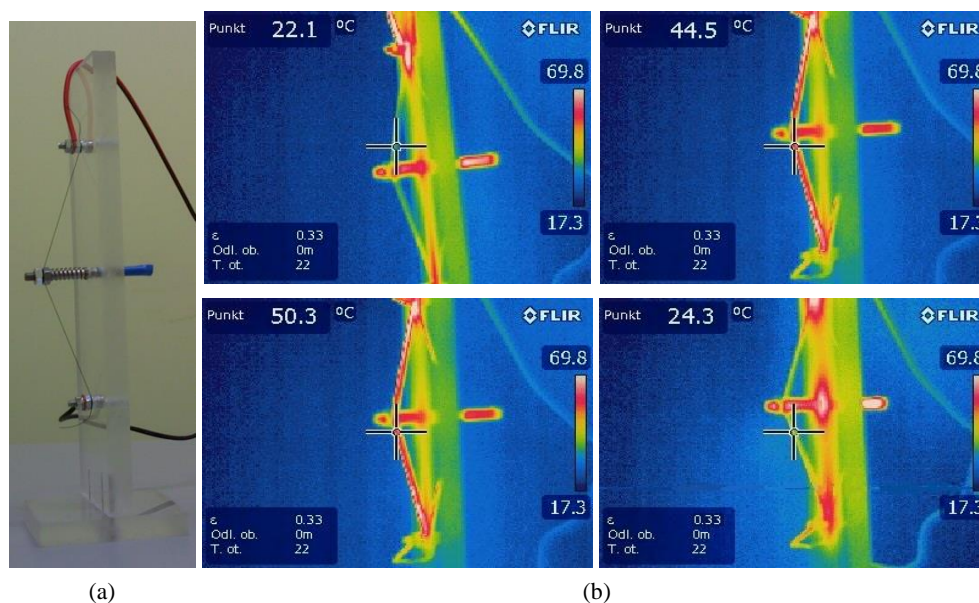

Fig. 9. Test of the linear SMA actuator using a thermal camera: (a) photo of the designed SMA actuator; (b) martensite-austenite transformation in the SMA actuator

In order to make use of the SMA wire as a linear actuator, different parameters and their relationships were investigated. The desired parameters of the linear actuator have been calculated using in-house software.

This study will be useful in precise controlling of an SMA wire actuator with and without external sensor feedback. The control system of the thermal switch with an SMA wire will be elaborated in the future work.

References

- [1] Lagoudas D.C., *Shape Memory Alloys: Modeling and Engineering Applications*, Springer (2008).
- [2] Barbarino S., Saavedra Flores E.I., Ajaj R.M., Dayyani I., Friswell M.I., *A review on shape memory alloys with applications to morphing aircraft*, Smart Materials and Structures, vol. 23, no. 6 (2014), DOI:10.1088/0964-1726/23/6/063001.
- [3] Song G., Ma N., Li H.-N., *Applications of shape memory alloys in civil structures*, Engineering Structures 28, pp. 1266-(2006).
- [4] Kłapyta G., Kciuk M., *Experimental measurements of shape memory alloys wires*, Archives of Electrical Engineering, vol. 61, no. 2, pp. 129-138 (2012).
- [5] Kluszczyński K., Kciuk M., *SMA actuators: theory, performance curves and design problems*, Compel, vol. 32, no. 4, pp. 1417-1427 (2013).
- [6] Khol M., *Shape Memory Microactuators*, Springer (2004).

-
- [7] Rao A., Srinivasa A., Reddy J., *Design of Shape Memory Alloy (SMA) Actuators*, Springer (2015).
 - [8] Nowak L., Mikołajewicz J., Pietrowski W., *Field-circuit model of the thermal phenomena in axial-symmetry electromagnetic devices*, Przegląd Elektrotechniczny (in Polish), vol. 85, no 6, pp. 63-66 (2009).
 - [9] Jayander J., Patel R.V., Nikumb S., Ostojic M., *Modelling and gain scheduled control of shape memory alloy actuators*, in Proc. IEEE Conf. Control Appl., pp. 767-772 (2005).
 - [10] Dutta S.M., Ghorbel F.H., *Differential hysteresis modeling of a shape memory alloy wire actuator*, IEEE Transactions on Mechatronics, vol. 10, no. 2, pp. 189-197 (2005).
 - [11] Almeida L.A.L., Deep G.S., Lima A.M.N., Neff H., *The Limiting Loop Proximity (L2P) Hysteresis Model*. IEEE Transaction on Magnetics, vol. 39, no. 1, pp. 523-528 (2002).
 - [12] Kciuk M., Chwastek K., Kluszczyński K., Szczygłowski J., *A study on hysteresis behaviour of SMA linear actuators based on unipolar sigmoid and hyperbolic tangent functions*. Sensors and Actuators A-Physical, vol. 243, pp. 52-58 (2016).
 - [13] Technical Characteristics of Flexinol® Actuator Wires, Dynalloy, <http://www.dynalloy.com>, accessed April 2016.