

## METHOD OF EARTH FAULT LOOP IMPEDANCE MEASUREMENT WITHOUT NUISANCE TRIPPING OF RCDs IN 3-PHASE LOW-VOLTAGE CIRCUITS

Stanisław Czapp

Gdańsk University of Technology, Faculty of Electrical and Control Engineering, G. Narutowicza 11/12,  
80-233 Gdańsk, Poland (✉ [stanislaw.czapp@pg.edu.pl](mailto:stanislaw.czapp@pg.edu.pl), +48 58 347 1398)

### Abstract

Verification of electrical safety in low-voltage power systems includes the measurement of earth fault loop impedance. This measurement is performed to verify the effectiveness of protection against indirect contact. The widespread classic methods and meters use a relatively high value of the measuring current ( $5 \div 20$ ) A, so that they are a source of nuisance tripping of *residual current devices* (RCDs). The meters dedicated to circuits with RCDs usually use an extremely low value of current (lower than 15 mA), which in many cases it is not acceptable in terms of the measurement accuracy. This paper presents a method of earth fault loop impedance measurement in 3-phase circuits, without nuisance tripping of RCDs – the concept of measurement, the meter structure and the experimental validation. The nuisance tripping is avoided in spite of the use of measuring current value many times higher than that of the rated residual current of RCDs. The main advantage of the proposed method is the possibility of creating values of measuring current in a very wide range, what is very important with regard to accuracy of the measurement.

Keywords: power systems, electrical safety, fault current, fault protection, impedance measurement.

© 2019 Polish Academy of Sciences. All rights reserved

### 1. Introduction

Faults in power systems, especially a short-circuit, can be dangerous for persons and equipment. Power grids [1], power transformers [2, 3] and power electronics circuits [4] are protected especially against such a fault, including the earth fault. To protect elements of a power system, their impedance is usually estimated [5–8]. The impedance value is used for evaluation of power quality as well [9]. However, calculation or measurement of a power system impedance is primarily performed in the case of analysing protection against electric shock – protection against indirect contact [10–12].

The basic rules protecting a person's safety are included in the standard [11], and the requirements for its verification are presented mainly in the standard [12]. Within the frame of verification of electrical installations, their inspection and testing should be performed. According to [11], the following tests shall be carried out:

- a) continuity of conductors;
- b) insulation resistance measurement of conductors;

- c) insulation resistance measurement for confirming the effectiveness of protection by SELV (*Safety Extra-Low Voltage*), PELV (*Protected Extra-Low Voltage*), as well as electrical separation;
- d) insulation resistance/impedance measurement for confirming the effectiveness of floor and wall resistance/impedance;
- e) polarity;
- f) the effectiveness of automatic disconnection of supply;
- g) the effectiveness of additional protection;
- h) phase sequence;
- i) functional;
- j) voltage drop.

To verify the effectiveness of protection against indirect contact by automatic disconnection of supply in low-voltage TN systems (solidly earthed power systems with a metallic earth current path), the measurement of earth fault loop impedance is mainly performed. When such a protective measure is applied, a disconnecting device is obliged to switch off the supply in the circuit within a specified time, in case of a fault of negligible impedance between the line conductor and the protective conductor (or an exposed-conductive-part). The above-mentioned requirement can be described by the following expression:

$$Z \leq \frac{V_0}{I_a}, \tag{1}$$

where:  $Z$  is the earth fault loop impedance comprising the source, the line conductor and the protective conductor;  $V_0$  is the nominal line-to-earth voltage of the installation;  $I_a$  is the current causing automatic disconnection of supply within the time specified in the standard [11].

In practice, the earth fault loop impedance measurement is performed with the use of an “artificial short-circuit” method [13, 14]. In this method (Fig. 1) the voltages before ( $V_{L1}$ ) as well as after ( $V_{Z0}$ ) closing switch  $S$  are measured.

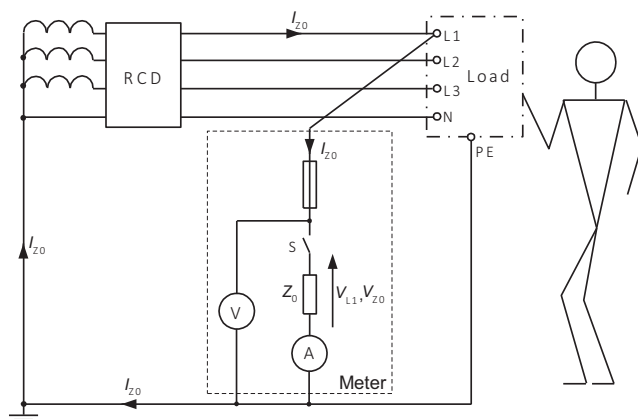

Fig. 1. Verification of a person’s safety – the principles of the earth fault loop impedance measurement in a TN system using the “artificial short-circuit” method; RCD – a residual current device.

If the value of meter short-circuit impedance  $Z_0$  is known, the measured earth fault loop impedance  $Z$  can be calculated as follows:

$$\underline{Z} = \frac{\Delta V}{I_{Z0}} = \frac{V_{L1} - V_{Z0}}{\frac{V_{Z0}}{\underline{Z}_0}} = \underline{Z}_0 \left( \frac{V_{L1}}{V_{Z0}} - 1 \right), \tag{2}$$

where:  $Z$  is the earth fault loop impedance to be measured;  $Z_0$  is the impedance of the meter (parameter of the meter/test instrument);  $V_{L1}$  is the voltage measured before closing switch  $S$ ;  $V_{Z0}$  is the voltage measured after closing switch  $S$ ;  $I_{Z0}$  is the measuring current (mainly depends on the impedance  $Z_0$ ).

In order to achieve an acceptable accuracy of the earth fault loop impedance measurement, the measuring current value cannot be very low. A very low value of this current gives a very low difference between voltages  $V_{L1}$  and  $V_{Z0}$ , and in consequence it is impossible to determine the impedance properly, especially if a voltage fluctuation occurs.

Based on the considerations included in [14], a measurement error  $\delta Z$  can be calculated according to the following expression:

$$\delta Z = \frac{\sqrt{1 + \left(\frac{Z}{Z_0}\right)^2 + 2\frac{Z}{Z_0} \cos(\varphi_Z - \varphi_{Z0})} - 1}{\frac{Z}{Z_0}} \quad (3)$$

where  $\varphi_Z - \varphi_{Z0}$  is the phase difference between the earth fault loop impedance  $Z$  and the impedance of the meter  $Z_0$ .

The lower value of the impedance  $Z_0$  of the meter – the higher value of the measuring current  $I_{Z0}$ , and – in consequence – the lower measurement error (better accuracy). Taking into account (3), Fig. 2 presents values of the measurement error  $\delta Z$  as a function of phase angle  $\varphi_Z$  of the loop impedance  $Z$ , for two values of measuring current  $I_{Z0}$ . It is assumed that the phase angle of the meter impedance  $Z_0$  is equal to  $\varphi_{Z0} = 0^\circ$  (resistive load – very common solution).

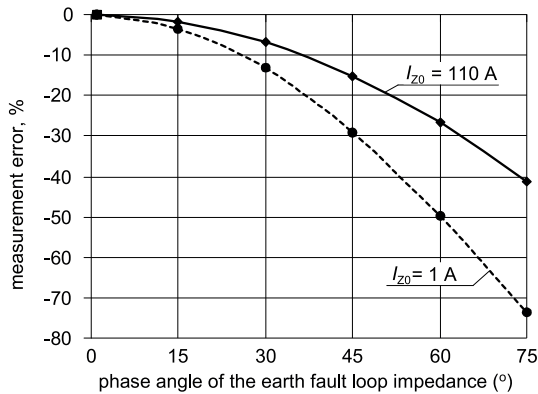

Fig. 2. Measurement error  $\delta Z$  as a function of phase angle  $\varphi_Z$  of the earth fault loop impedance  $Z$ , for two values of measuring current  $I_{Z0} = 1$  A and 110 A. The phase angle of the meter impedance  $Z_0$  is  $\varphi_{Z0} = 0^\circ$ , and the reference earth fault loop impedance is  $Z = 1 \Omega$ .

One can see that the measuring current  $I_{Z0} = 1$  A ( $Z_0 = 200 \Omega$ ) gives higher values of the error  $\delta Z$  than the measuring current  $I_{Z0} = 110$  A ( $Z_0 = 1 \Omega$ ). What is important, the values of the error are negative (too low impedance is measured). It is dangerous, because the real impedance is higher than the measured one – real impedance gives a lower value of short-circuit current, which can be too low to ensure automatic disconnection of supply within the required time. According to [15], the total measurement error should not exceed 30%.

Thus, the value of measuring current in final circuits of electrical installations should be as high as possible, at least around a few amperes. Moreover, a higher value of current enables to

find out weak connections of the conductors in the tested circuit. Unfortunately, leakage currents or the value of current giving a sufficient accuracy of the earth fault loop impedance measurement are responsible for nuisance tripping of *residual current devices* (RCDs) [16, 17].

The most popular RCDs in electrical installations have the rated residual current  $I_{\Delta n} = 30 \text{ mA}$ . This is due to the requirement of standard HD 60364-4-41 [11] and the requirement of standard HD 60364 for special installations or locations (parts 7–700 of this standard). As it is reported in [16] the value of measuring current equal to or higher than 30 mA may cause nuisance tripping of a 30 mA RCD, because the measuring current ( $I_{Z0}$  in Fig. 1) is the residual current for the RCD. Therefore, it is necessary to construct meters which force a relatively high value of the measuring current and simultaneously do not cause nuisance tripping of RCDs of  $I_{\Delta n} = 30 \text{ mA}$  [18, 19].

## 2. Short review of available methods and meters for circuits with RCDs

### 2.1. Method that uses very low value of current

The most common method of the earth fault loop impedance measurement, which is used in circuits with RCDs, involves a very low value of the measuring current. Since the most popular RCDs have  $I_{\Delta n} = 30 \text{ mA}$ , the applied measuring current value should not exceed 15 mA ( $0.5I_{\Delta n}$ ). Oscillograms of the measuring current waveforms for two popular meters are presented in Fig. 3.

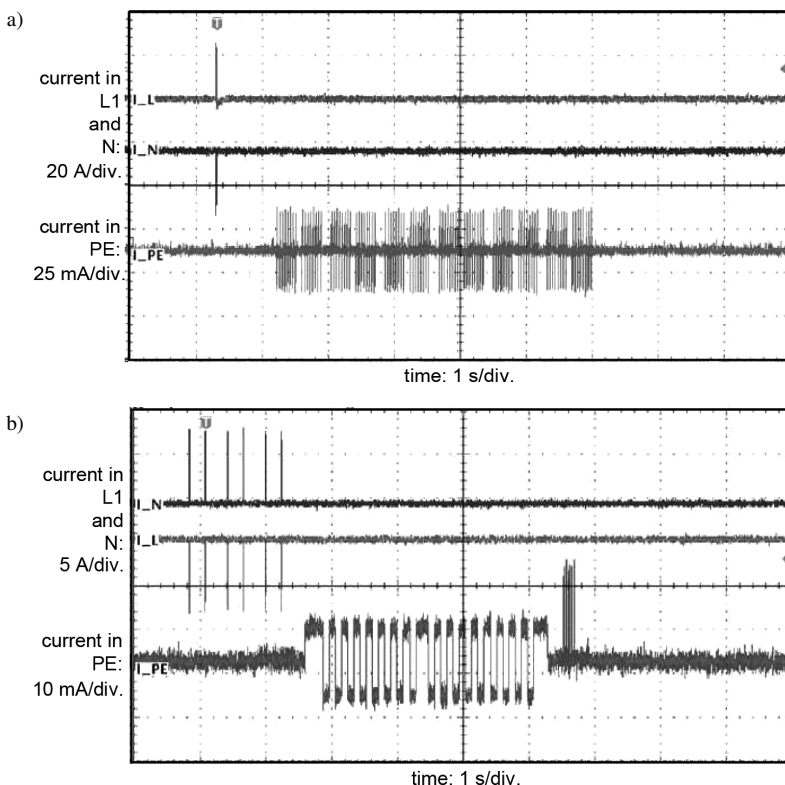

Fig. 3. Oscillograms of the measuring current (current in PE) of selected meters that use a low-value current: a) Meter 1  $\Rightarrow$  15 mA rms; b) Meter 2  $\Rightarrow$  10 mA rms [20].

For Meter 1 (Fig. 3a) the measuring current (current in PE conductor) value is approx. equal to 15 mA. Meter 2 (Fig. 3b) is characterized by the measuring current value approx. equal to 10 mA. It is obvious that such values of current are extremely low and in many cases do not give a sufficient accuracy of the measurement.

Some manufacturers of the loop impedance meters inform that a proper measurement with the use of such low values of current can be performed for impedances not less than 0.5  $\Omega$ . In practice, in many final circuits the earth fault loop impedance is lower than 0.5  $\Omega$ . Therefore, methods using a low value of current cannot be used.

## 2.2. Method that uses half-wave current

Another method which theoretically enables the earth fault loop impedance measurement without nuisance tripping of RCDs, uses pulses of direct current both for saturation of magnetic core of an RCD and for measurement of the impedance (Fig. 4). Unfortunately, in this method a direct measuring current is used and the meter is suitable only for the measurement in final circuits where resistance is a dominant component [21].

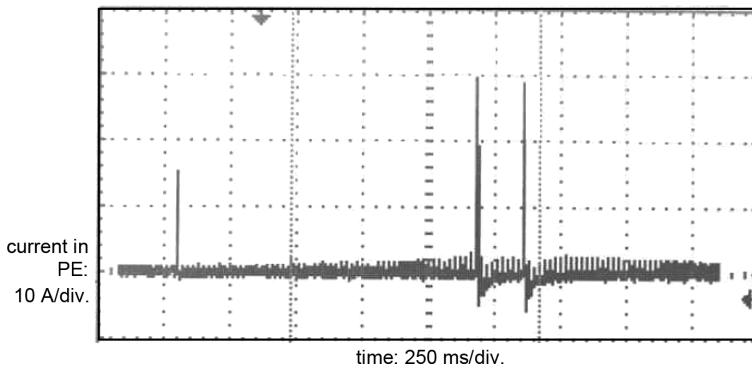

Fig. 4. An oscillogram of the measuring current of a selected meter that uses a half-wave current; Meter 3  $\Rightarrow$  28 A peak [21].

In the same way, only direct (half-wave) current is also used in a method described in the patent [22]. On the contrary to the presented methods, for a proper earth fault loop impedance measurement, a full-wave measuring current of a relatively high value should be used.

## 3. Proposed method of circuit testing without nuisance tripping of RCDs

### 3.1. Principles of new method

The high-value-current measurement of the earth fault loop impedance in circuits with RCDs is possible after recognizing properties of their internal tripping circuit. With the exception of special applications, the most popular RCDs installed in electrical installations are AC-type (for detection of sinusoidal residual currents) and A-type (for detection of both sinusoidal residual currents and direct pulsating currents) [23]. Both types of RCDs are mainly composed of an iron core current transformer CT and an electromechanical relay ER (Fig. 5). In order to make tripping of an RCD, a sufficient value of the secondary current  $I_s$  has to be generated in the secondary

circuit of the RCD. A relatively high value of  $I_s$  makes tripping of ER and disconnection of the supply occurs then. The value of this current depends on the value of the induced secondary voltage  $E_s$ . This secondary voltage is a function of magnetic induction  $\Delta B$  in the iron core:

$$E_s = f(\Delta B, N_s, s_{Fe}), \quad (4)$$

where:  $\Delta B$  – variation of magnetic induction;  $N_s$  – the number of turns of the secondary winding of CT;  $s_{Fe}$  – the cross-section of core CT.

In the conventional method of measurement, in the case of flow of a sinusoidal measuring current higher than the rated residual current of RCDs, both AC-type and A-type RCDs are tripped out. In the proposed method, before switch S is closed (Fig. 5) and measuring current  $I_{Z0}$  flows, the parallel circuit with a rectifier, forcing a smooth direct current  $I_{DC}$ , is activated. Thus, a composite current  $I_{Z0} + I_{DC}$  flows through the current transformer CT – the greater value of  $I_{DC}$  the smoother composite current – and tripping of the RCD is blocked. A detailed structure of a new meter using the proposed method is presented in Fig. 6.

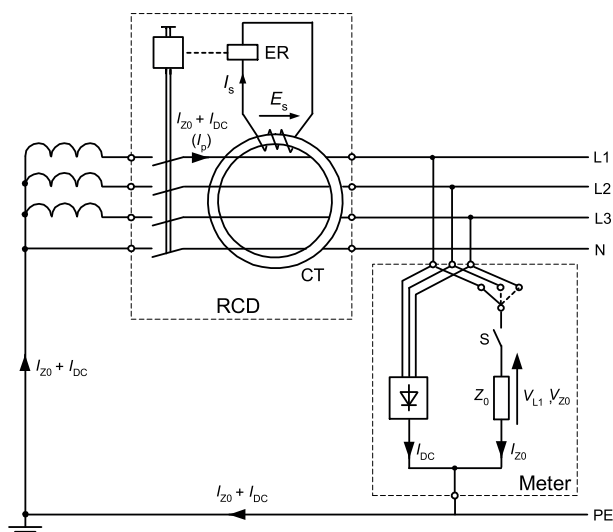

Fig. 5. A simplified diagram of the earth fault loop impedance measurement in 3-phase circuits with RCDs, according to the proposed method; CT – current transformer; ER – electromechanical relay; S – switch;  $I_p$  – primary current of CT;  $I_s$  – secondary current of CT.

The new meter is connected to the line conductors L1, L2, L3 and to the protective conductor PE (Fig. 6). First, as in typical meters, voltage  $V_{L1}$  is measured (before closing switch  $S_{L1}$ ) and stored in the control unit CU. Fig. 7a presents an equivalent circuit for this stage of measurement. Next, direct current  $I_{DC}$  is increased gradually, by successive closing of switches  $S_{RD}$ ,  $S_{R2}$ ,  $S_{R3}$  in the rectifier unit RU (Fig. 6). It is necessary to control rising  $I_{DC}$  value to avoid nuisance tripping of RCD – too fast rising could give high variation of magnetic induction in the core of CT. After  $I_{DC}$  value is stabilized, sinusoidal measuring current  $I_{Z0}$  is increased by successive closing of switches  $S_{L1}$ ,  $S_1$ ,  $S_2$ . When resistances  $R_1$  and  $R_2$  in the unit MCU are bypassed, measuring current  $I_{Z0}$  is limited in the meter only by impedance  $Z_0$  (Fig. 7b). In this stage, voltage  $V_{Z0}$  is measured and stored. The known values  $V_{L1}$ ,  $V_{Z0}$  and  $I_{Z0}$  enable to calculate the earth loop impedance on the base of (2). After finishing the measurement of earth fault loop impedance, the aforementioned switches have to be opened in a controllable way as well.

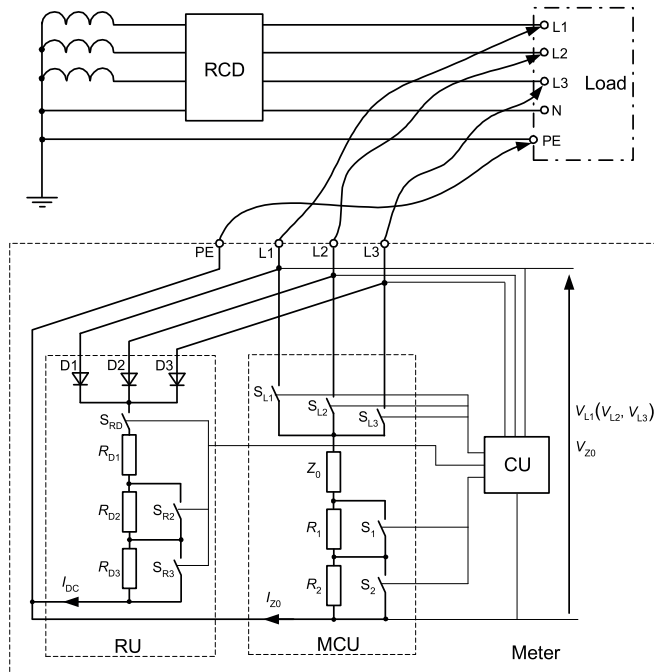

Fig. 6. A detailed structure of the proposed meter; CU – control unit; RU – rectifier unit; MCU – measuring current unit; D1, D2, D3 – diodes of the 3-phase rectifier;  $R_{D1}$ ,  $R_{D2}$ ,  $R_{D3}$  – resistances for limiting direct current  $I_{DC}$ ;  $S_{RD}$ ,  $S_{R2}$ ,  $S_{R3}$  – switches for bypassing/switching resistances in the rectifier unit;  $R_1$ ,  $R_2$  – resistances for limiting measuring current  $I_{Z0}$ ;  $S_1$ ,  $S_2$  – switches for bypassing/switching resistances in the measuring current unit;  $Z_0$  – main impedance of the meter (usually resistance in meters dedicated to final circuits);  $S_{L1}$ ,  $S_{L2}$ ,  $S_{L3}$  – switches which enable the measurement of earth fault loop impedance in successive phases L1, L2, L3;  $V_{L1}$ ,  $V_{L2}$ ,  $V_{L3}$  – the measured voltage in phases L1, L2, L3 respectively, before closing relevant switches,  $V_{Z0}$  – the measured voltage after closing relevant switches.

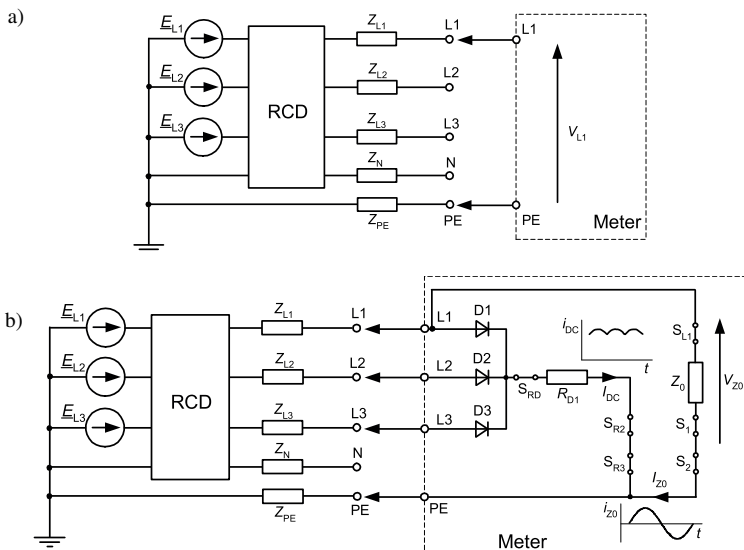

Fig. 7. An equivalent circuit during the earth fault loop impedance measurement between L1 and PE:  
 a)  $V_{L1}$  is measured; b)  $V_{Z0}$  is measured (voltage drop across impedance  $Z_0$ ).

To measure the impedance in other phases (L2 and L3), voltages  $V_{L2}$  and  $V_{L3}$  are measured respectively, instead of  $V_{L1}$ , and switches  $S_{L2}$ ,  $S_{L3}$  are closed. The value of measuring current  $I_{Z0}$  to be used in order to avoid nuisance tripping of RCDs has to be coordinated with the value of DC component  $I_{DC}$ . Fig. 8 presents a waveform of the composite current  $I_{Z0} + I_{DC}$  as a function of  $I_{DC}$  value. In the steady state,  $I_{DC}$  should be higher than the peak-to-peak value of measuring current  $I_{Z0}$ . The composite current is unidirectional then, and the lower pulsation of this current the more certain that nuisance tripping of the RCD does not occur.

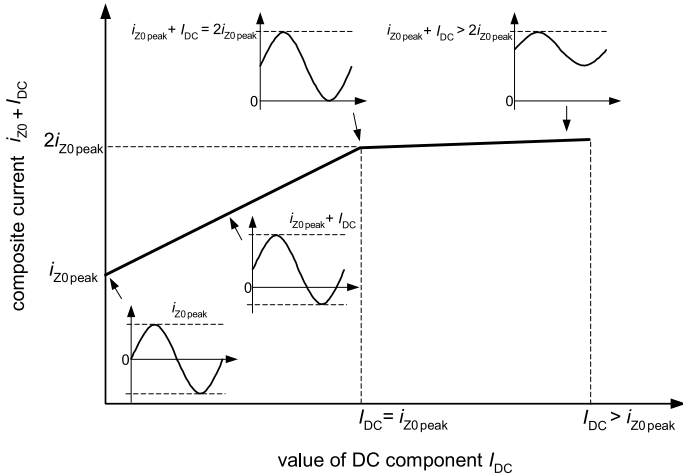

Fig. 8. A waveform of the composite current  $i_{Z0} + I_{DC}$  as a function of DC component ( $I_{DC}$ ) value.

### 3.2. Experimental validation of proposed method

The proposed idea of preventing from nuisance tripping of RCDs has been verified experimentally. As it was mentioned in the previous section, the tripping threshold of RCDs mainly depends on the value of induced secondary voltage  $E_s$  in CT of RCDs (Fig. 5). In the proposed method, DC current ( $I_{DC}$ ) is intended to reduce the value of the secondary voltage due to saturation of the iron core of CT. In the experimental verification, the induced secondary voltage was observed for a few values of DC current  $I_{DC}$ , consecutively superimposed on the measuring (primary) current  $I_{Z0}$ . The value of  $I_{Z0}$  was approx. equal to the rated residual current of RCDs under test. In the experiment two CTs of RCDs were tested:

- 300 mA, AC-type;
- 300 mA, A-type.

In the proposed method, a three-phase rectifier is recommended to be used as the source of DC current. A waveform of DC current from such a rectifier is relatively smooth. For simplification of the laboratory test, the forced DC current  $I_{DC}$  was generated by a programmable power supply and was almost smooth.

Figure 9 presents results of the test for AC-type current transformer CT. In the case of sinusoidal measuring (primary) current  $I_{Z0}$  without DC component ( $I_{DC} = 0$ ), the waveform of the induced secondary voltage is characterized by a relatively high peak-to-peak voltage (Fig. 9a). When DC component is equal to  $I_{DC} = 150$  mA ( $0.5I_{\Delta n}$ ), the peak-to-peak induced secondary voltage is reduced almost to 0 (Fig. 9b). Such a negligible value of the voltage cannot cause nuisance tripping of RCD.



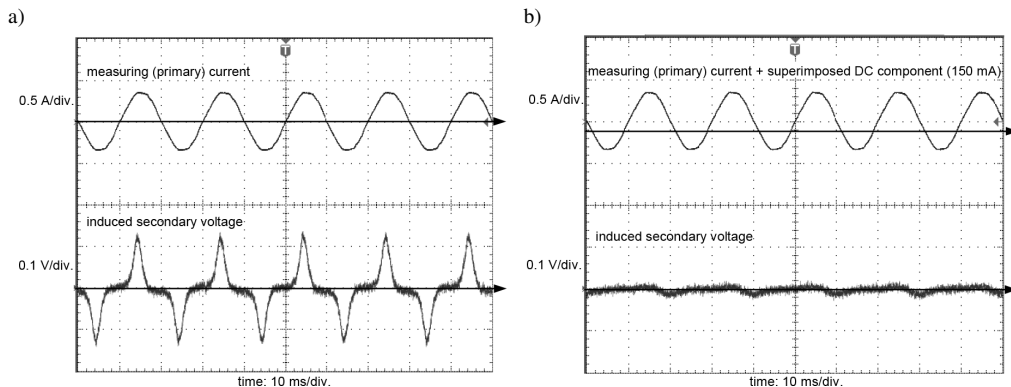

Fig. 9. Oscillograms of the induced secondary voltage in CT of an AC-type 300 mA RCD for a sinusoidal measuring current  $I_{Z0}$  and DC components: a)  $I_{DC} = 0$ ; b)  $I_{DC} = 150$  mA.

A-type RCDs are more resistant to DC current component (Fig. 10). When the sinusoidal measuring (primary) current flows, the induced secondary voltage is almost the same for both  $I_{DC} = 0$  (Fig. 10a) and  $I_{DC} = 150$  mA (Fig. 10b). The voltage is noticeably reduced only from the value of  $I_{DC} = 600$  mA (Fig. 10c). When the measuring (primary) current  $I_{Z0}$  has a half-wave shape (Fig. 11) and DC component equal to  $I_{DC} = 600$  mA is superimposed on

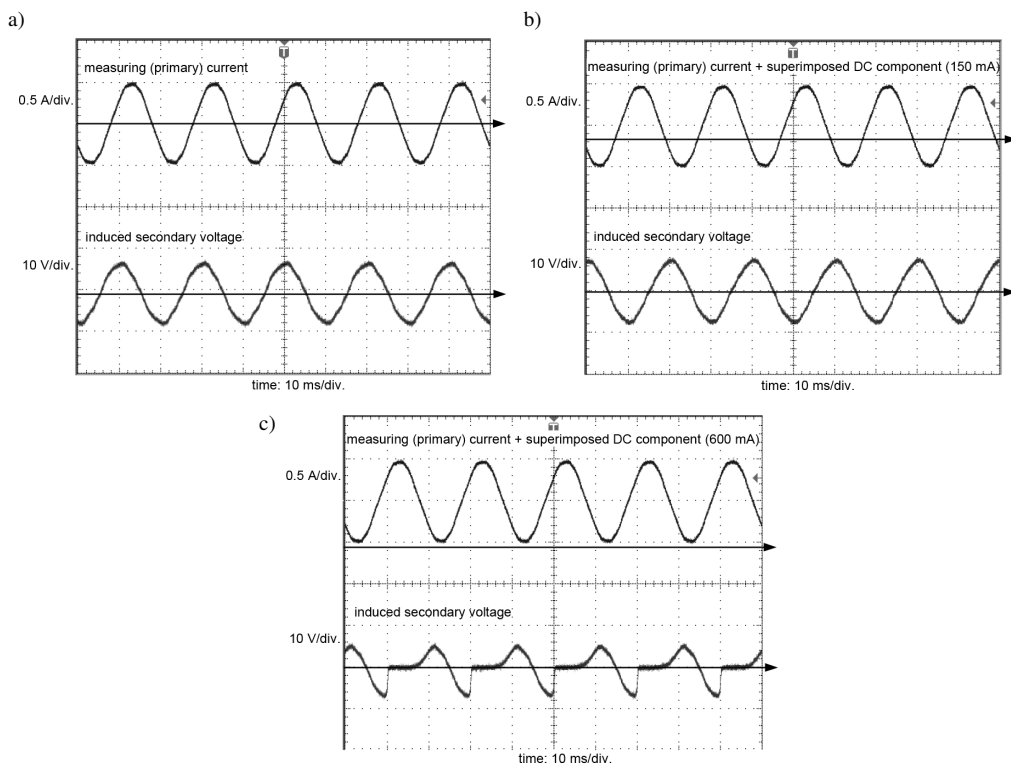

Fig. 10. Oscillograms of the induced secondary voltage in CT of an A-type 300 mA RCD for a sinusoidal measuring current  $I_{Z0}$  and DC components: a)  $I_{DC} = 0$ ; b)  $I_{DC} = 150$  mA; c)  $I_{DC} = 600$  mA.

this half-wave (polarity of both currents is the same), the induced secondary voltage is almost negligible (Fig. 11b).

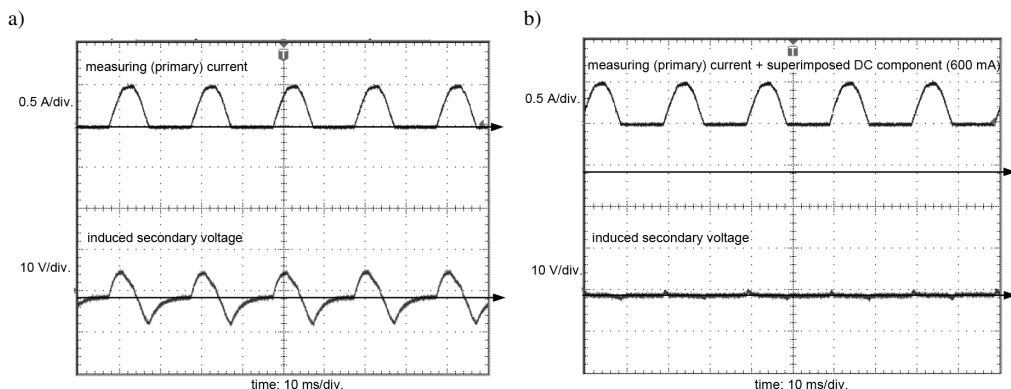

Fig. 11. Oscillograms of the induced secondary voltage in CT of an A-type 300 mA RCD for a half-wave measuring current  $I_{Z0}$  and DC components: a)  $I_{DC} = 0$ ; b)  $I_{DC} = 600$  mA.

It is clearly visible that nuisance tripping of RCDs during the earth fault loop impedance measurement can be blocked by controllable forcing the measuring current  $I_{Z0}$  and DC component  $I_{DC}$ . The value of measuring current  $I_{Z0}$  to be used in a particular meter is a function of DC component  $I_{DC}$ , and a mutual relation of these two currents can be created by the constructor of the meter.

For typical final circuits of low-voltage installations, a sufficient value of measuring current is around  $I_{Z0} = (5 \div 10)$  A (it gives an acceptable accuracy – in practice the measurement error does not exceed permissible 30%). The saturating current  $I_{DC}$  is recommended to be at least 2÷3 times higher than  $I_{Z0}$  in order to make the composite current  $I_{Z0} + I_{DC}$  unidirectional with a relatively low pulsation.

#### 4. Conclusions

The methods of earth fault loop impedance measurement in circuits with RCDs, applied in the meters available on the market, are mainly based on the use of a very low value of measuring current ( $< 15$  mA). In many cases such a low value of measuring current is not acceptable due to a low accuracy of the measurement. The method of earth fault loop impedance measurement proposed in this paper enables the measurement without nuisance tripping of RCDs. The value of measuring current can be relatively high (10 A or even more). The value achieved by the constructor of the meter is a compromise between the desired accuracy of the measurement and the economic as well as technical aspects (cost, size, high/low mass *etc.*).

#### References

- [1] Zhang, X., Wei, J., Yue, S., Zha, X. (2018). An analytical method for mapping alarm information to model of power grid fault diagnosis. *IEEJ Transactions on Electrical and Electronic Engineering*, 13(6), 823–830.
- [2] Krstivojevic, J.P., Djurić, M.B. (2015). Verification of transformer restricted earth fault protection by using the Monte Carlo method. *Advances in Electrical and Computer Engineering*, 15(3), 65–72.

- [3] Gutten, M., Janura, R., Šebök, M., Korenčiak, D., Kučera, M. (2016). Measurement of short-circuit effects on transformer winding with SFRA method and impact test. *Metrol. Meas. Syst.*, 23(4), 521–529.
- [4] Cui, J., Shi, G., Gong, Ch. (2017). A fast classification method of faults in power electronic circuits based on support vector machines. *Metrol. Meas. Syst.*, 24(4), 701–720.
- [5] Ghanem, A., Rashed, M., Sumner, M., Elsayes, M.A., Mansy, I.I.I. (2017). Grid impedance estimation for islanding detection and adaptive control of converters. *IET Power Electronics*, 10(11), 1279–1288.
- [6] Pablo, G., Guerrero, J.M., García, J., Navarro-Rodriguez, A., Sumner, M. (2014). Low frequency signal injection for grid impedance estimation in three phase systems. *IEEE Energy Conversion Congress and Exposition (ECCE)*, 1542–1549.
- [7] Nino, E.E., Nassif, A.B., Xu, W. (2005). Network impedance measurement methods based on on-site data. *Proc. of the 37th Annual North American Power Symposium*, 569–575.
- [8] Palethorpe, B., Sumner, M., Thomas, D.W.P. (2000). Power system impedance measurement using a power electronic converter. *Proc. on Harmonics and Quality of Power*, 208–213.
- [9] Kaspirek, M., Mezera, D. (2013). Voltage quality parameters in LV distribution grids in dependence, on short circuit impedance. *22nd Int. Conf. Electricity Distribution*, Stockholm.
- [10] Czapp, S., Guzinski, J. (2018). Electric shock hazard in circuits with variable-speed drives. *Bulletin of the Polish Academy of Sciences: Technical Sciences*, 66(3), 361–372.
- [11] Low-voltage electrical installations – Part 4-41: Protection for safety – Protection against electric shock, HD 60364-4-41 (2017).
- [12] Low-voltage electrical installations – Part 6: Verification, IEC 60364-6. (2016).
- [13] Aigner, M., Schmutzner, E., Sigl, Ch., Wieland, T., Fickert, L. (2013). Fehlerschleifenimpedanz-Messung in Niederspannungsnetzen mit Wechselrichtern. 8. *Intern. Energiewirtschaftstagung an der TU Wien, IEWT 2013*, Wien.
- [14] Roskosz, R., Ziolko, M. (2003). Measurement accuracy of short-circuit loop impedance in power systems. *Proc. XVII IMEKO World Congress, TC4*, Dubrovnik, Croatia, 903–907.
- [15] Electrical safety in low-voltage distribution systems up to 1000 V a.c. and 1500 V d.c. – Equipment for testing, measuring or monitoring of protective measures – Part 3: Loop impedance, IEC 61557-3. (2007).
- [16] Czapp, S. (2012). Fault loop impedance measurement in low voltage network with residual current devices. *Elektronika ir Elektrotechnika*, 122(6), 109–112.
- [17] Escriva-Escriva, G., Roldan-Porta, C., de Jong, E.C.W. (2016). Nuisance tripping of residual current circuit breakers in circuits supplying electronic loads. *Electric Power Systems Research*, 131, 139–146.
- [18] Czapp, S., Borowski, K., Dobrzynski, K., Klucznik, J., Lubosny, Z. (2015). A new method of fault loop resistance measurement in low voltage systems with residual current devices. *Intern. Conf. PowerTech 2015*, Eindhoven, The Netherlands.
- [19] Czapp, S., Borowski, K. (2016). Experimental verification of a new method of loop resistance testing in low voltage systems with residual current devices. *21st IMEKO TC-4 Intern. Symposium on Understanding the World Through Electrical and Electronic Measurement, and 19th Intern. Workshop on ADC Modelling and Testing*, Budapest, Hungary, 245–250.
- [20] Czapp, S., Borowski, K. (2016). Evaluation of applicability of classic methods of a fault loop impedance measurement to circuits with residual current devices. *Acta Energetica*, 28(3), 45–52.
- [21] Digital PSC-Loop Tester, Model KEW4120A, Instruction Manual, Kyoritsu.
- [22] Harris, D.R., Litherland, M.B., Flowerday, A.L. (1988). Circuit testing. European patent no. 295800.
- [23] Residual current operated circuit-breakers without integral overcurrent protection for household and similar uses (RCCBs) – Part 1: General rules, IEC 61008-1. (2010).