

Improved modeling of new three-phase high voltage transformer with magnetic shunts

M. CHRAYGANE¹, N. EL GHAZAL¹, M. FADEL¹, B. BAHANI¹,
A. BELHAIBA¹, M. FERFRA², M. BASSOUI²

¹High School of Technology, MSTI Laboratory, Ibnou Zohr University, Agadir-Morocco
e-mail: nm.elghazal@gmail.com

²Mohammadia's School of Engineers, Research Team in Electrical Energy & Control
Mohamed V University, Rabat-Morocco
e-mail: elghazal@ymail.com

(Received: 28.10.2014, revised: 20.12.2014)

Abstract: This original paper deals with a new approach for the study of behavior in nonlinear regime of a new three-phase high voltage power supply for magnetrons, used for the microwave generators in industrial applications. The design of this system is composed of a new three-phase leakage flux transformer supplying by phase a cell, composed of a capacitor and a diode, which multiplies the voltage and stabilizes the current. Each cell, in turn, supplies a single magnetron. An equivalent model of this transformer is developed taking into account the saturation phenomenon and the stabilization process of each magnetron. Each inductance of the model is characterized by a non linear relation between flux and current. This model was tested by EMTP software near the nominal state. The theoretical results were compared to experimental measurements with a good agreement. Relative to the current device, the new system provides gains of size, volume, cost of implementation and maintenance which make it more economical.

Key words: transformer, three-phase, modeling, EMTP, microwaves, power supply

1. Introduction

Figure 1 shows the scheme of the new three-phase HV power supply for N magnetron, used as a microwave energy source (treated case: $N = 1$ magnetron per phase). A new three-phase magnetic leakage transformer, not yet so far modeled or manufactured, is the basic element of this new power supply. The new transformer supplies by phase a voltage doubler and a current stabilizer cell. This special transformer with shunts ensures the anodic current stabilization in each magnetron by saturation of its magnetic circuit. The characteristics of the magnetron [1-7] as well as these limit values impose a proper design of its power supply. Unlike the conventional transformer, the leakage flux in the shunt is of the same order as both the primary and secondary fluxes. Thus, the theory of classical transformers does not apply in the case of the transformer with shunts. On the other hand, the design and optimization of such

devices can be facilitated using simulation tools taking into account the geometry and the non linear magnetic properties of materials.

In this article, we introduce an equivalent circuit of the new transformer that meets these conditions. Integrated into an overall scheme of the new HV power supply for a single magnetron by phase, it is adapted to the modeling of the assembly by a numerical calculation of transient electrical circuits EMTP (Electro Magnetic Transients Program). Experimental measurements, obtained for a single-phase transformer with shunts, used to validate the simulated results of this model.

The paper is organized as follows: firstly, the mathematical equations characterizing this new special transformer are described in order to drive a new equivalent model. Secondly, an implementation of obtained model using EMTP software was presented. The obtained results were compared with those already found in feasibility study already done [8-12-13-18], and experimental measurements for the classical power supply for a single magnetron [1-7].

2. The modeling principle

The new transformer cannot be separated from the external circuits, including each of the three magnetrons, because the equivalent diagram must reflect the behavior of the whole. It is therefore necessary to find a formulation that will allow the simultaneous resolution of the electric and magnetic equations of the entire system. Too complex to be solved analytically, the solution can be only numerical using suitable software. In addition, the choice of materials and dimensions of the new transformer should be possible, with a view to a possible optimization. A simple model of representation is not sufficient, because its parameters must be able to be extracted directly. To account for the stabilizing effect of the new power supply of magnetrons, it is necessary to consider the nonlinearities of the system. As well, the EMTP software accepts the data relating to the nonlinear saturable inductances and the global model used operates this facility. Taking all these considerations into account, the development equations cannot be that particular to adapt to the constraints of the used EMTP code and the link of the equivalent circuit with the construction parameters.

3. Theoretical study of the new three-phase transformer with shunts

In the proposed study, the new three-phase transformer is considered without iron losses (hysteresis and Foucault currents). The leakages that exist are only channeled in the shunts. The leakage of air dispersion is negligible. Only the saturation phenomenon is taken into consideration.

3.1. Description

The magnetic circuit of the new three-phase transformer is of the type tetrahedron (Fig. 1). Each phase has three columns, a central core receives the windings and the others at the ends are used to close the magnetic circuit.

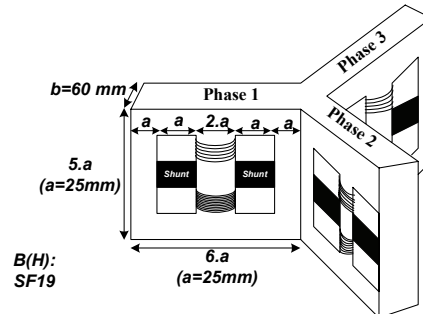

Fig. 1. Magnetic circuit of type tetrahedron of the new three-phase transformer

To realize a magnetic circuit of the type tetrahedron, three identical magnetic circuits of the single-phase transformer with shunts can be used. The magnetic circuits being separated, the magnetic fluxes in the three circuits are independent. Although there is independence of fluxes, a three-phase secondary system is obtained.

Figure 2 shows the structure of the new three-phase transformer with shunts, not yet modeled or manufactured, that will be used in the HV power supplies for N magnetrons per phase (treated case: $N = 1$ magnetron per phase).

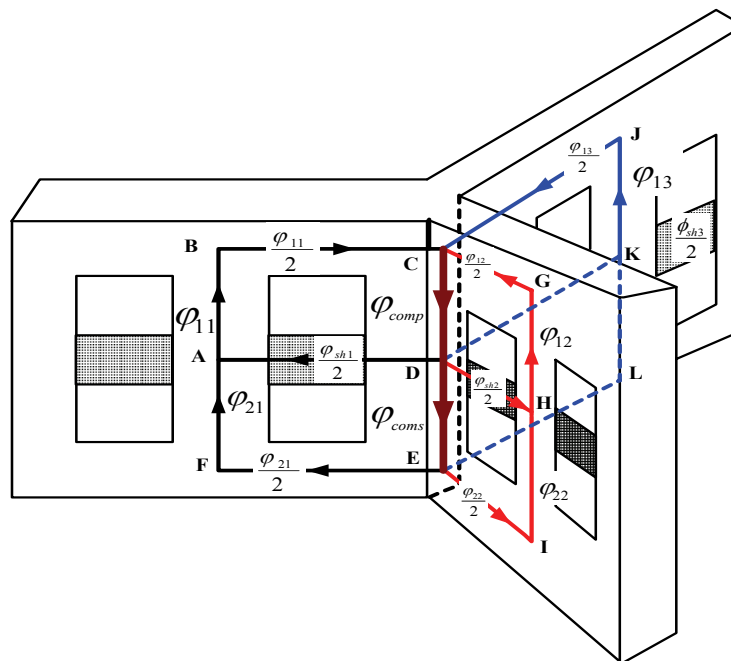

Fig. 2. Distribution of fluxes in the magnetic circuit of the new three-phase transformer

The magnetic shunts are used to deflect an important part of the flux circulating between the primary and secondary winding. Taking into account the dimensions of residual gaps and

the saturation state of materials, the magnetic fluxes in the air can be considered negligible compared to the fluxes through the shunts.

The three primary windings constitute a balanced three-phase load given that these three windings are the same. This means that the effective values of the three voltages are equal and the three voltages are shifted relative to it 120 degrees.

3.2. Concept of calculation

The primary quantities are shown by r_{1i} , n_1 , i_{1i} , u_{1i} , (phase $i = 1, 2, 3$) and the secondary quantities are materialized by r_{2i} , n_2 , i_{2i} , u_{2i} , (phase $i = 1, 2, 3$). The fluxes ϕ_{1i} , ϕ_{2i} , ϕ_{3i} (phase $i = 1, 2, 3$) are respectively: the flux passing through the primary, the secondary and the shunts of each phase as shown in Figure 2: r_{1i} : primary winding resistance (phase i); i_{2i} : secondary winding resistance (phase i); n_1 : number of turns in the primary coil of each phase; n_2 : number of turns in the secondary coil of each phase; u_{1i} : voltage of the primary winding (phase i); u_{2i} : voltage of the secondary winding.

The dimensions in millimeters of the magnetic circuit are marked by letters A, B, C, D... L and are related to the mean force line flux in the different portions of the circuit.

$$AB = HG = KJ = DC = 2*a$$

$$FA = ED = IH = LK = 2*a$$

$$DA = DH = DK = 2.5*a$$

$$CB = CJ = CG = 2.5*a$$

$$EF = EI = EL = 2.5*a$$

3.2.1. The electric equations

The governing electric equations of the transformer operation are obtained by application of the Ohm generalized law in primary and secondary winding of each phase.

For the phase 1:

$$u_{11} = r_{11}i_{11} + n_1 \frac{d\phi_{11}}{dt}, \quad (1.1)$$

$$u_{21} = n_2 \frac{d\phi_{21}}{dt} - r_{21}i_{21}, \quad (2.1)$$

For the phase 2:

$$u_{12} = r_{12}i_{12} + n_1 \frac{d\phi_{12}}{dt}, \quad (1.2)$$

$$u_{22} = n_2 \frac{d\phi_{22}}{dt} - r_{22}i_{22}, \quad (2.2)$$

For the phase 3:

$$u_{13} = r_{13}i_{13} + n_1 \frac{d\phi_{13}}{dt}, \quad (1.3)$$

$$u_{23} = n_2 \frac{d\varphi_{23}}{dt} - r_{23}i_{23}, \quad (2.3)$$

3.2.2. The magnetic equations

To have the equations relating to the magnetic circuit of this transformer, we apply the formula of magnetic circuits to the various contours of Figure 2 (Hopkinson law). So it comes:

$$\begin{aligned} \text{Considering: (balanced three-phase load)} \\ \varphi_{comp} = \varphi_{11} + \varphi_{12} + \varphi_{13} = 0 \quad (\text{primary side}), \\ \varphi_{coms} = \varphi_{21} + \varphi_{22} + \varphi_{23} = 0 \quad (\text{secondary side}). \end{aligned}$$

For the phase 1:

The contour ABCDA:

$$R_{AB}\varphi_{11} + R_{BC}\frac{\varphi_{11}}{2} + R_{CD}\varphi_{comp} + R_{DA}\frac{\varphi_{sh1}}{2} = n_1 i_{11}.$$

Posing:

$$R_{p1} = R_{AB} + \frac{R_{BC}}{2}; R_{sh1} = \frac{R_{DA}}{2}.$$

The following equation is obtained:

$$R_{p1}\varphi_{11} + R_{sh1}\varphi_{sh1} = n_1 i_{11}. \quad (3.1)$$

The contour ADEFA:

$$R_{FA}\varphi_{21} + R_{EF}\frac{\varphi_{21}}{2} + R_{DE}\varphi_{coms} - R_{DA}\frac{\varphi_{sh1}}{2} = -n_2 i_{21}.$$

Posing:

$$R_{s1} = R_{DA} + \frac{R_{EF}}{2}; R_{sh1} = \frac{R_{DA}}{2}$$

As well for this contour the following equation is obtained:

$$R_{s1}\varphi_{21} - R_{sh1}\varphi_{sh1} = -n_2 i_{21}. \quad (4.1)$$

The contour BCEFB:

$$R_{p1}\varphi_{11} + R_{s1}\varphi_{21} = n_1 i_{11} - n_2 i_{21}. \quad (5.1)$$

The Equations (3.1), (4.1) and (5.1) are supplemented by the additional relation reflecting the conservation of fluxes in the phase 1:

$$\varphi_{11} = \varphi_{21} + \varphi_{sh1}. \quad (6.1)$$

3.2.3. New transformer equivalent model circuit

To study the operation of the new transformer model using the EMTP code, it is convenient to bring its equivalent three-phase circuit to the secondary. To do this, each phase equivalent scheme will be treated:

Phase 1.

Multiplying by n_2/n_1 and putting the quantity $n_2\phi_{11}$ in the form

$$n_2 \left(\frac{n_2}{R_{p1}} \right) \left(\frac{R_{p1}}{n_2} \right) \phi_{11},$$

it comes:

$$u'_{11} = r'_{11} i'_{11} + n_2 \frac{d}{dt} \left\{ \frac{n_2^2}{R_{p1}} \frac{R_{p1}}{n_2} \phi_{11} \right\}.$$

The quantities

$$\frac{n_2^2}{R_{p1}} \quad \text{and} \quad \frac{R_{p1}\phi_{11}}{n_2}$$

are respectively the dimensions of an inductance and an electric current which we may call L_{p1} and i_{p1} , which allows writing the above equation in the form:

$$u'_{11} = r'_{11} i'_{11} + n_2 \frac{d}{dt} \{L_{p1} i_{p1}\}.$$

Using the Equation (6.1) and by writing that:

$$n_2\phi_{21} = \frac{n_2^2}{R_{s1}} \frac{R_{s1}}{n_2} \phi_{21} = L_{s1} i_{s1},$$

$$n_2\phi_{sh1} = \frac{n_2^2}{R_{sh1}} \frac{R_{sh1}}{n_2} \phi_{sh1} = L_{sh1} i_{sh1},$$

$$n_2\phi_{11} = \frac{n_2^2}{R_{p1}} \frac{R_{p1}}{n_2} \phi_{11} = L_{p1} i_{p1}.$$

It comes:

$$\frac{d}{dt} \{L_{p1} i_{p1}\} = \frac{d}{dt} \{L_{s1} i_{s1}\} + \frac{d}{dt} \{L_{sh1} i_{sh1}\}$$

By expressing the quantity $n_2\phi_{21}$ the Equation (2.1) also becomes:

$$u_{21} = \frac{d}{dt} \{L_{s1} i_{s1}\} - r_{21} i_{21}.$$

With:

$$L_{s1} = \frac{n_2^2}{R_{p1}}.$$

On the other hand, multiplying by n_2/n_1 the current expression i_{11} as a function of ϕ_{11} and ϕ_{sh1} , extract from the Equations (3.1), (4.1) and (5.1), the following equation is obtained:

$$\frac{n_1}{n_2} i_{11} = \frac{R_{p1}}{n_2} \varphi_{11} + \frac{R_{sh1}}{n_2} \varphi_{sh1}$$

This equation can be written in the form:

$$i'_{11} = i_{p1} + i_{sh1}.$$

Using the Equation (4.1), (5.1) and (6.1), the following expression is obtained:

$$i_{21} = \frac{-R_{s1}}{n_2} \varphi_{21} + \frac{R_{sh1}}{n_2} \varphi_{sh1}.$$

This expression can be written in the form:

$$i_{21} = -i_{s1} + i_{sh1}.$$

So,

$$i_{sh1} = i_{s1} + i_{21}.$$

The following complete system of electric and magnetic equations is obtained:

$$u'_{11} = n'_1 i'_{11} + n_2 \frac{d}{dt} \{L_{p1} i_{p1}\}, \quad (7.1)$$

$$u_{21} = \frac{d}{dt} \{L_{s1} i_{s1}\} - r_{21} i_{21}, \quad (8.1)$$

$$i'_{11} = i_{p1} + i_{sh1}, \quad (9.1)$$

$$i'_{sh1} = i_{s1} + i_{21}, \quad (10.1)$$

$$n_2 \frac{d}{dt} \varphi_{11} = n_2 \frac{d}{dt} \varphi_{21} + n_2 \frac{d}{dt} \varphi_{sh21}. \quad (11.1)$$

This equation system responds to the equivalent diagram in the first phase of the new three-phase transformer with magnetic shunts.

By perfectly similar calculations, the equation system which responds to the equivalent diagram of the phase 2 and 3 permits to find the models indicated in Figures 4 and 5. The model elements including the inductances are not the same.

It is possible to decompose R_{shi} ($i = \text{phase } 1, 2, 3$) to highlight the constant overall reluctance R_{shi}^e of air gaps between shunts and cores, in parallel with R_{shi}^f relative to correspond largest part of the path in each phase entirely ferromagnetic environments.

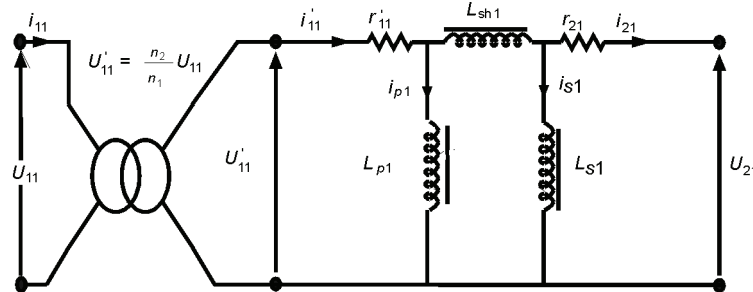

Fig. 3. Equivalent model of the phase 1 of the new three-phase transformer with shunts brought back to the secondary

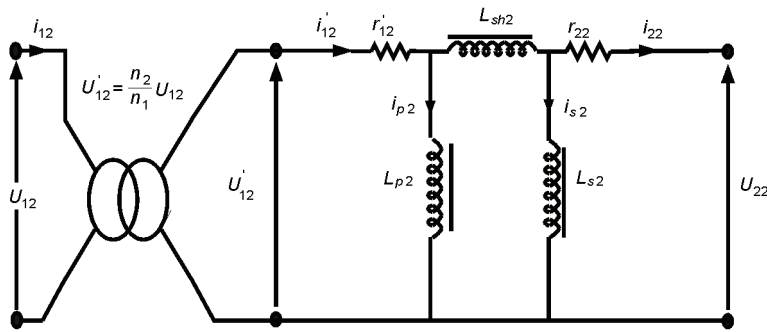

Fig. 4. Phase 2 of the new three-phase transformer: equivalent model

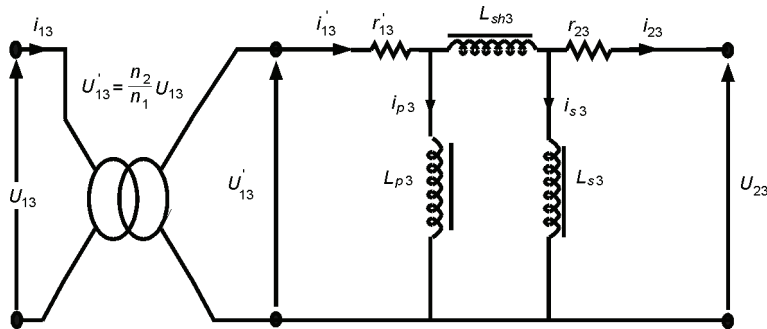

Fig. 5. Phase 3 of the new three-phase transformer: equivalent model

$$L_{shi}^e (i = \text{phase } 1, 2, \dots, 3) = \frac{n_2^2}{R_{shi}^e}$$

is equivalent to the corresponding constant inductance in parallel on

$$L_{shi}^f = \frac{n_2^2}{R_{shi}^e}$$

hence the equivalent diagram seen from the secondary of the new transformer which will be used in power supplies for magnetrons.

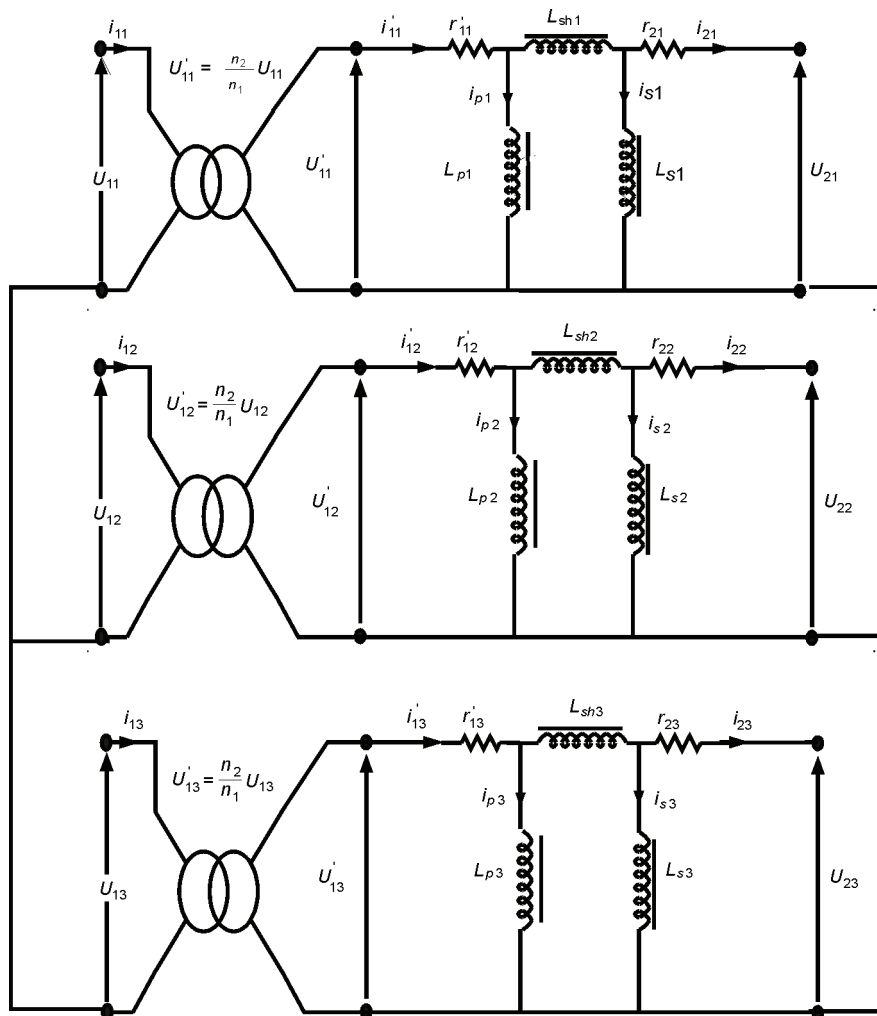

Fig. 6. New model of the new three-phase transformer with magnetic shunts

4. Validation of the model of the new power supply

The advantage of this new model is part of its equivalent circuit which seems more convenient to study the operation of the new transformer using the EMTP code. The immediate interest of this model is to be able to assign to each inductance a non linear relation between

the flux and the current in the form $n_2\phi(i)$, from the geometrical parameters of the new transformer magnetic circuit.

To translate the variation law of total flux $n_2\phi(i)$ in terms of i of each inductance, the magnetization curve $B(H)$ of the material can be used, using the relations: $\phi = B.S$ and $i = l^*H/n_2$.

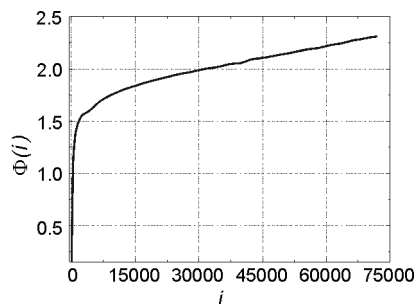

Fig. 7. Experimental $B(H)$ for each section of the studied magnetic circuit

The model of the new transformer is integrated in the new HV power supply circuit from the source to the magnetrons. Each tube microwave is represented by an equivalent diagram deduced from its electrical characteristics which is formally similar to that of a diode with dynamic resistance $R = 350$ Ohms and threshold voltage $E \approx 3800$ Volts.

Exploiting the EMTP code, the electric behavior of the HV circuit of the new three-phase power supply with single magnetron per phase is simulated (Fig. 8). The waveforms obtained from this simulation are shown in Figure 10.

This figure shows that in nominal operation ($U_{11} = U_{12} = U_{13} = 220$ V and $f = 50$ Hz) the results of simulation by EMTP of the new device, in non linear regime, confirm the results obtained during a feasibility study already done. The relative differences will never exceed 6%.

$$\eta = \frac{\sum ((\text{exp}) - \text{theo})}{\sum ((\text{exp}) + \text{theo})}$$

These signals have the same form as those of a classical HV power supply using a transformer for a single magnetron. The phase shift of 120 degrees between them confirms the absence of interaction between magnetrons.

Taking into account the accuracy of the various data and of the permissible tolerances acceptable on the operation of the magnetron, the modeling was deemed satisfactory.

Encouraged by the successful results, a new structure of the magnetic circuit has been undertaken. In the core of common return of the three circuits (the primary side (also secondary)), the total flux then is considered zero. Therefore, the core returning in the two primary and secondary sides has no interest (Fig. 9). The new power supply will be considered therefore a different version of the single-phase model currently manufactures among the manufacturers of domestic or industrial microwave ovens.

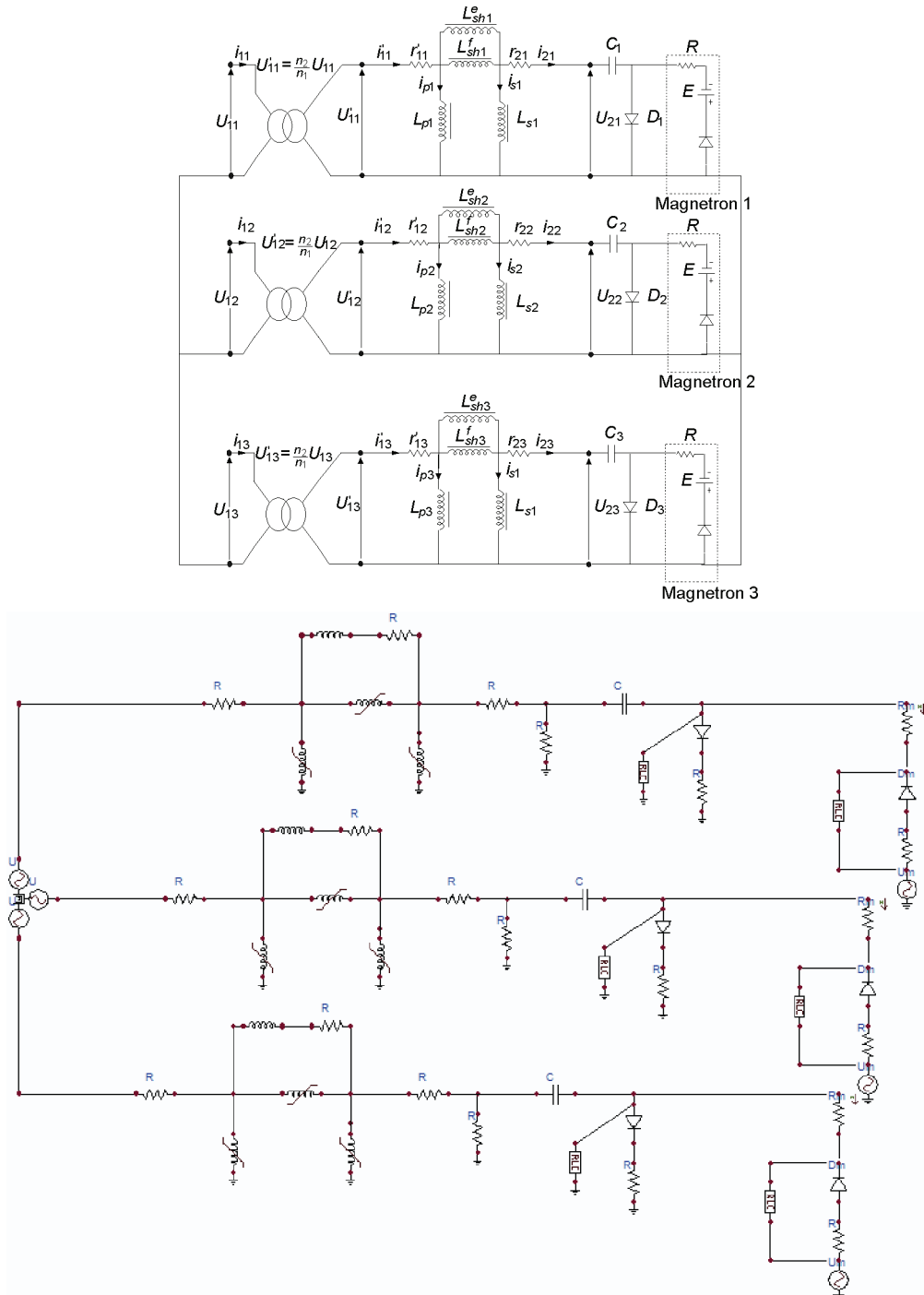

Fig. 8. a) Modeling of the new three-phase transformer with magnetic shunts using the EMTP code; b) simulated model with EMTP of the new three phase power supply

Fig. 9. New type of magnetic circuit of the new three-phase transformer with magnetic shunt

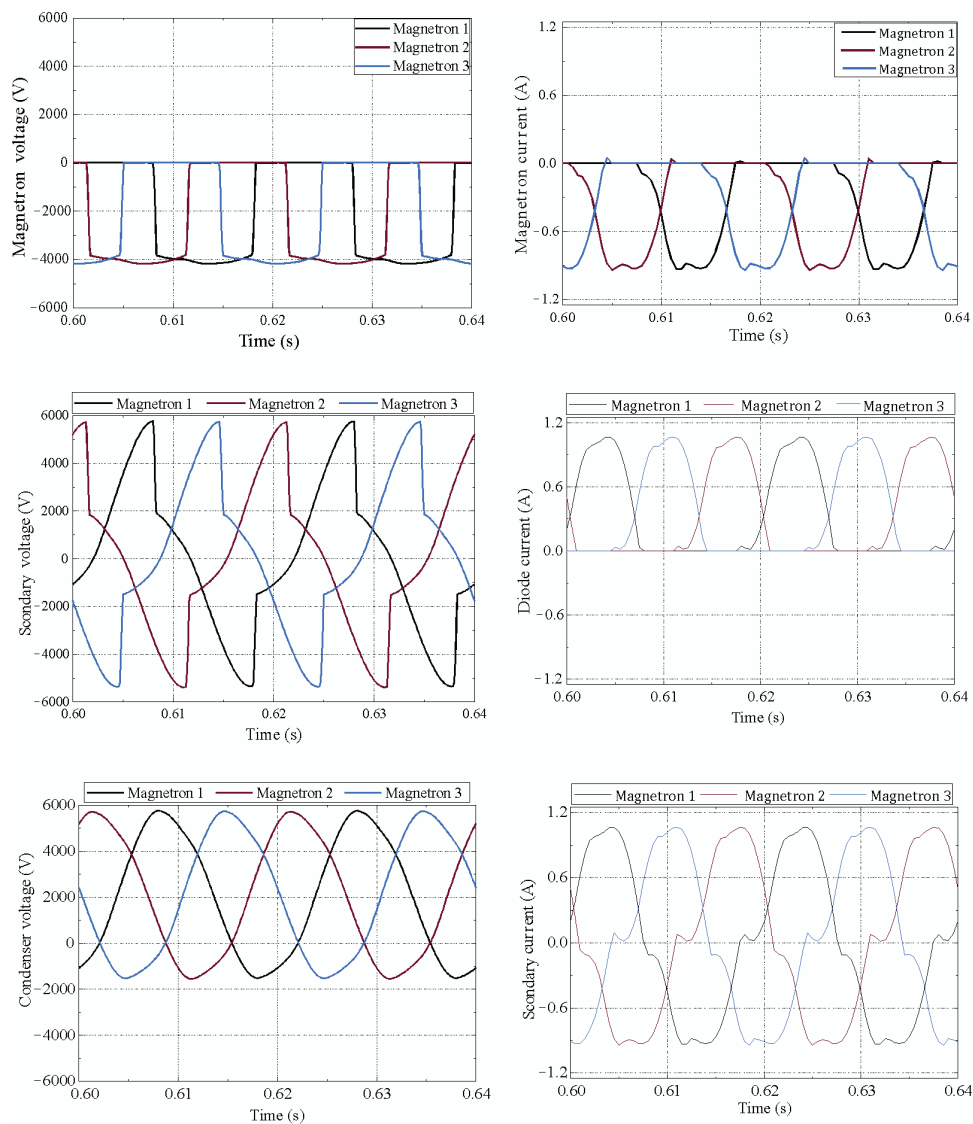
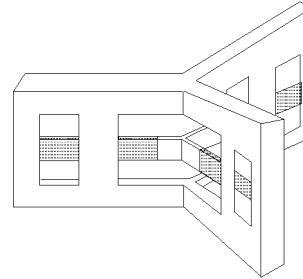

Fig. 10. Simulation results: currents and voltages waveforms of the new three-phase power supply using EMTF code (nominal mode)

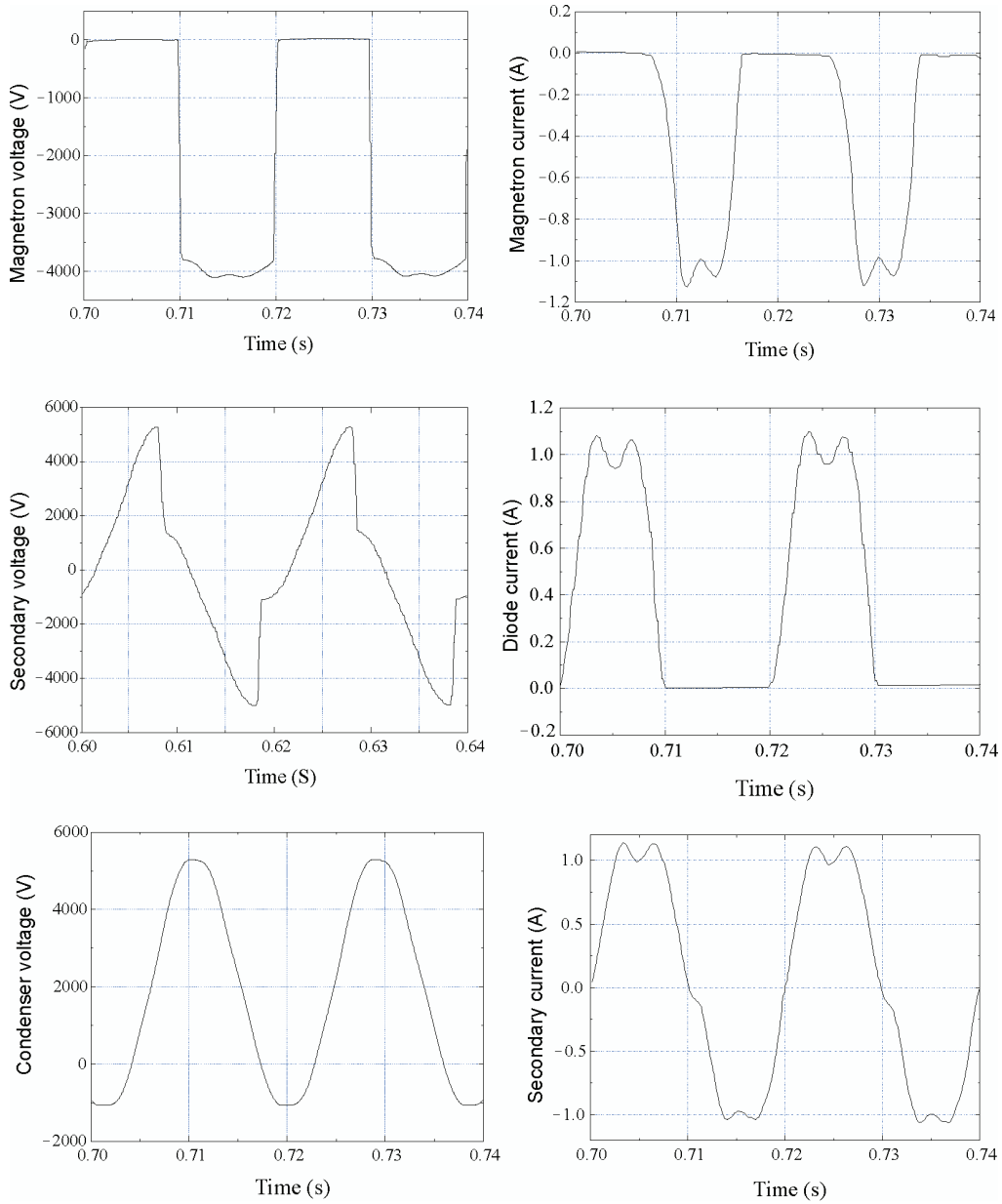

Fig. 11. Experimental results: currents and voltages waveforms of the single-phase power supply (nominal mode)

5. Verification of the regulating process of a magnetron current

During the simulation of the model using the EMTP code, we managed to observe the stability of the magnetron current variations with respect to the mains voltage.

Figures 11 and 12 show the waveform of the current magnetron in the respective cases 200 V and 240 V ($\pm 10\%$ of the rated voltage). We note that the maximum amplitude of the current never exceeds the permissible limit value recommended by the manufacturer ($I_{\max} = 1.2$ A). We can say that with this model, the stabilization process of the magnetron current is completely recovered.

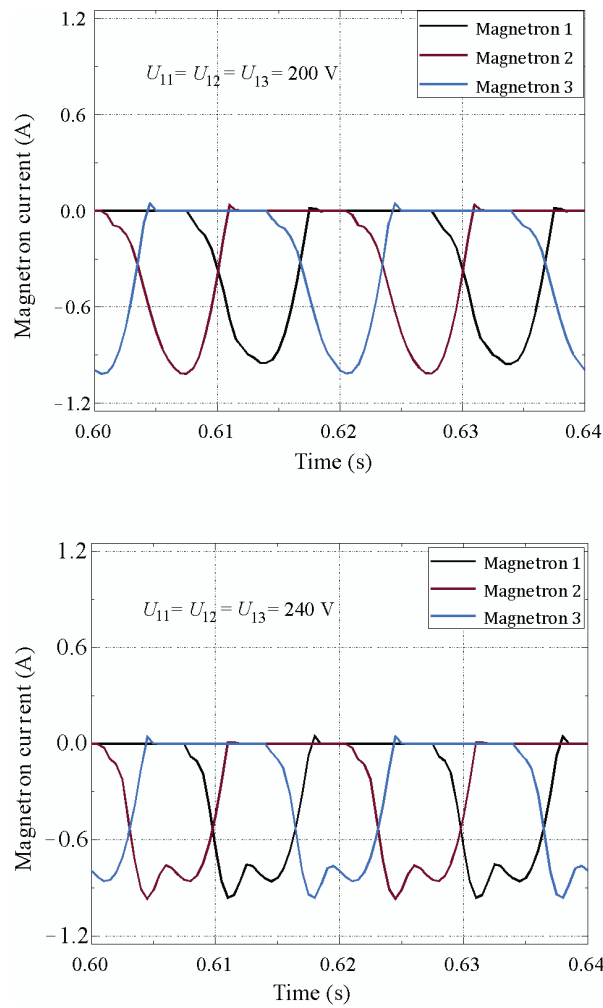

Fig. 12. Waveforms of the current magnetron for $U_{11} = U_{12} = U_{13} = 200$ V and $U_{11} = U_{12} = U_{13} = 240$ V

6. Conclusion

In this article, a new original model able to represent the best possible characteristics of saturation of a new three-phase transformer with magnetic shunts, not yet so far modeled or made, was concluded.

After the dimensioning of its new three-phase flux leakage transformer, the observation of the correct functioning of various branches of the circuit power was successful.

At the end of simulation with EMTP code, the regulation process current in each magnetron and flow rate of full microwave power was verified. This preserves the protection of all magnetrons against any change in the input voltage of the three-phase power supply network.

The results confirm that there are no interactions between the three magnetrons. The failure of one or more magnetrons does not affect the operation of other powered magnetrons. As perspectives, this study can be extended without any problems in case of operation of the new power supply for $N > 1$ magnetrons per phase in nominal scale.

References

- [1] Chraygane M., Ferfra M., El Khouzaï M., Hlimi B., *Étude de l'état magnétique interne global du transformateurs à shunts d'une alimentation pour générateurs micro-ondes à magnétron destinés aux applications industrielles*. Télécom'2003 et 3ème JFMMA– Marrakech. Communication, pp 436-439 (2003).
- [2] Chraygane M., Ferfra M., Hlimi B., *Modélisation d'une alimentation haute tension pour générateurs micro-ondes industriels à magnétron*. Revue 3EI, 41, pp 37-47 (2005).
- [3] Chraygane M., *Modélisation avec EMTP d'une nouvelle génération d'alimentation haute tension monophasée pour générateurs microondes à magnétrons destinés aux applications industrielles*. Thèse de doctorat d'état, Université Ibn Zohr Agadir, Maroc, n° 113/07 (2007).
- [4] OuldAhmedou M., Chraygane M., Ferfra M., *New π Model Validation Approach to the Leakage Flux Transformer of a High Voltage Power Supply Used for Magnetron for the Industrial Micro-Waves Generators 800 Watts-2450 MHz*. International Review of Electrical Engineering IREE 5(3) (May-June 2010).
- [5] OuldAhmedou M., Ferfra M., Nouri R., Chraygane M., *Improved π Model of the Leakage Flux Transformer Used for Magnetrons*. International Conference on Multimedia Computing and Systems, IEEE Conference, Ouazazat-Morocco (07-09 April 2011).
- [6] Ould Ahmedou M., Ferfra M., El Ghazal N. et al., *Implementation and Optimization Under Matlab Code of a HV Power Transformer For Micowave Generators Supplying Tow Magnetrons*, Journal of Theoretical and Applied Information Technology 33(2) (30 November 2011).
- [7] Belhaiba A., Chraygane M., OuldAhmedou M., *Modélisation du bilan énergétique d'un générateur micro ondes industriel à un seul magnétron*. Conférence Méditerranéenne sur l'Ingénierie Sûre des Systèmes Complexes, MISC'11 Agadir-Morocco (27-28 Mai 2011).
- [8] El Ghazal N., Chraygane M., OuldAhmedou M., *Modélisation d'une alimentation haute tension à caractère triphasé pour générateurs micro ondes industriels à un magnétron par phase*. Conférence Méditerranéenne sur l'Ingénierie Sûre des Systèmes Complexes, MISC'11 Agadir-Morocco (27-28 Mai 2011).
- [9] El Ghazal N., OuldAhmedou M., Chraygane M., *Optimization of High Voltage Power Supply for Industrial Microwave Generators for one Magnetron*. Journal of Theoretical and Applied Information Technology 46(1): 001-010 (2012).
- [10] Belhaiba A., El Ghazal N., Chraygane M., *Improved optimization of the nominal functioning of a high voltage power supply for $N = 2$ magnetrons for microwave generators*, International Journal of Electrical and Computer Engineering, IJECE 2(5): 708-716 (October 2012).
- [11] Belhaiba A., Chraygane M., El Ghazal N., *Modeling the power of microwave generator for one magnetron by Matlab-simulink*. IEEE International Conference on Multimedia Computing and Systems, ICMCS'12, Tanger (10-12 may 2012).
- [12] El Ghazal N., Belhaiba A., Chraygane M. et al., *Feasibility study of a new three-phase HV power supply for microwaves generators supplying a one magnetron per phase*. International Conference on Multimedia Computing and Systems, IEEE, 2010.1109/ICMCS.2012.6320197, Tanger (2012).

- [13] El Ghazal N., Chraygane M., Belhiba A. et al., *Modeling of a New HV Power Supply with a Character Three-Phase for $N = 2$ Magnetrons by Phase for Industrial Micro-wave Generators*, International Symposium on Security and Safety of Complex Systems, Agadir (25-26 may 2012).
- [14] Belhaiba A., Chraygane M., OuldAhmedou M., *Modeling the power balance of microwaves generators for $N = 2$ magnetrons*. International Symposium On Security And Safety Of Complex Systems, Agadir (25-26 may 2012).
- [15] Belhiba A., Chraygane M., El Ghazal N., *Modeling and optimization of high voltage power supply for magnetron*, LAP LAMBERT Academic Publishing GmbH& Co. KG Heinrich-Böcking, pp. 6-8 66121, Saarbrücken, Germany (2013).
- [16] El Ghazal Naama, Chraygane M., Ferfra M., *Modeling of New Three-Phase High Voltage Power Supply For Industrial Microwave Generators With One Magnetron Per Phase*, International Journal of Electrical and Computer Engineering, IJECE 3(2) (2013).
- [17] Boubker B., Bouzit A., Chraygane M. et al., *Modeling of a New Single-Phase High Voltage Power Supply for Microwave Generators with Three Magnetrons*. International Journal of Electrical and Computer Engineering, IJECE 3(2) (April 2013).
- [18] El Ghazal N., Chraygane M., Belhaiba A., *Power Supplies of Magnetrons: Modeling, Simulation & Optimization*. LAP LAMBERT Academic Publishing GmbH&Co. KG Heinrich-Böcking, pp 6-8, 66121, Saarbrücken, Germany (2013).