

P. LACKI*, Z. KUCHARCZYK*, R.E. ŚLIWA**, T. GAŁACZYŃSKI**

EFFECT OF TOOL SHAPE ON TEMPERATURE FIELD IN FRICTION STIR SPOT WELDING

WPLYW KSZTAŁTU NARZĘDZIA NA POLE TEMPERATURY W PROCESIE PUNKTOWEGO ZGRZEWANIA TARCIOWEGO Z MIESZANIEM

Friction stir welding (FSW) is one of the youngest methods of metal welding. Metals and its alloys are joined in a solid state at temperature lower than melting points of the joined materials. The method is constantly developed and friction stir spot welding (FSSW) is one of its varieties. In the friction stir spot welding process a specially designed tool is brought into rotation and plunged, straight down, in the joined materials. Heat is generated as a result of friction between the tool and materials, and plastic deformation of the joined materials. Softening (plastic zone) of the joined materials occurs. Simultaneously the materials are stirred. After removal of the tool, cooling down the stirred materials create a solid state joint.

Numerical simulation of the process was carried out with the ADINA System based on the finite element method (FEM). The problem was considered as an axisymmetric one. A thermal and plastic material model was assumed for Al 6061-T6. Frictional heat was generated on the contact surfaces between the tool and the joined elements. The model of Coulomb friction, in which the friction coefficient depends on the temperature, was used.

An influence of the tool geometry on heat generation in the welded materials was analysed. The calculations were carried out for different radiuses of the tool stem and for different angles of the abutment. Temperature distributions in the welded materials as a function of the process duration assuming a constant value of rotational tool speed and the speed of tool plunge were determined. Additionally, the effect of the stem radius and its height on the maximum temperature was analysed. The influence of tool geometry parameters on the temperature field and the temperature gradient in the welded materials was shown. It is important regarding the final result of FSSW.

Keywords: Friction stir spot welding (FSSW), metal welding, FEM, Al 6061-T6

Zgrzewanie tarciove z przemieszaniem (FSW) jest jedną ze stosunkowo niedawno opracowanych metod łączenia metali. Należy do grupy metod łączenia metali i ich stopów w stanie stałym, w temperaturach niższych od temperatury topnienia łączonego materiału. Metoda jest stale rozwijana, a jedną z jej odmian jest punktowe zgrzewanie tarciove z przemieszaniem (FSSW).

W procesie punktowego zgrzewania tarciowego z przemieszaniem specjalnie zaprojektowane narzędzie wprowadzane jest w ruch obrotowy i wgłębiane, pionowo w dół, w obszar łączenia dwóch elementów. Wskutek tarcia narzędzia o materiał oraz plastycznego odkształcania materiału, generowane jest ciepło. Następuje zmiękczenie materiału łączonych elementów. Zmiękczonego materiału (uplastycznionego) jest stale mieszany. Po wyprowadzeniu narzędzia, przemieszany materiał stygnąc tworzy między spajanymi elementami złącze w stanie stałym.

Symulację numeryczną procesu za pomocą metody elementów skończonych wykonano z wykorzystaniem programu ADINA. Problem rozpatrywano jako zagadnienie osiowoosymetryczne. Przyjęto termoplastyczny model materiału – Al 6061-T6. Ciepło tarcia generowane jest na powierzchni kontaktu narzędzia z łączonymi elementami. Zastosowano model tarcia Coulomba, w którym współczynnik tarcia zależy od temperatury.

W pracy analizowano wpływ geometrii narzędzia na generowanie ciepła w zgrzewanym materiale. Obliczenia przeprowadzono dla różnych wartości promienia trzpienia narzędzia oraz kąta wieńca opory. Wyznaczono rozkłady temperatury w zgrzewanym materiale w funkcji czasu trwania procesu, przyjmując stałą wartość prędkości obrotowej narzędzia i prędkości jego wgłębiania. Analizowano także zależność maksymalnej temperatury od promienia i wysokości trzpienia. Wykazano wpływ parametrów geometrycznych narzędzia na pole temperatury i gradientu temperatury w zgrzewanym materiale, co jest ważne dla finalnego efektu połączenia materiałów technologią FSSW.

* CZĘSTOCHOWA UNIVERSITY OF TECHNOLOGY, 42-201 CZĘSTOCHOWA, 69 DĄBROWSKIEGO STR., POLAND

** RZESZÓW UNIVERSITY OF TECHNOLOGY, 35-959 RZESZÓW, 8 POWSTAŃCÓW WARSZAWY STR., POLAND

1. Introduction

Friction stir welding (FSW) is a process of metal welding, which was invented and patented by The Welding Institute – TWI Ltd., UK in 1991. The method is mainly used in the aircraft, automotive and shipbuilding industry. FSW method has many advantages. Welding possibility of the materials, which are hard to weld by traditional joining techniques, good mechanical properties of the weld, absence of shielding gases, lack of hot cracks, and also possibility of process mechanization are the main advantages of FSW. The method is constantly evolving. There are many variants of FSW beside the classical version, in which the tool moves along the straight line. Friction stir spot welding (FSSW) is one of them. First time this solution was implemented in manufacturing of Mazda RX-8 car in 2003.

In the friction stir spot welding process a specially designed cylindrical tool is introduced in rotation and inserted straight down into materials of welded parts, which are placed one above the other (Fig. 1). Working part of the tool consist of the shaped pin (penetrating part) and shoulder. In comparison with friction stir welding the tool does not move along the weld line. The pin height is less than the thickness of the joined parts, so the shoulder also gets into contact with the material surface during tool penetration. The pin and the shoulder are made of the harder and more resistant to wear material than the welded materials. During the process, heat is generated as a result of friction between the tool and the welded parts, and plastic deformation of the welded materials. The materials get soft, but the melting points are not reached. Softened and constantly stirred materials flows around the tool. After the required tool penetration and time of material stirring the tool is removed. Cooling down, the stirred materials create the solid-state weld. The obtained weld has a strength similar to that of the base material.

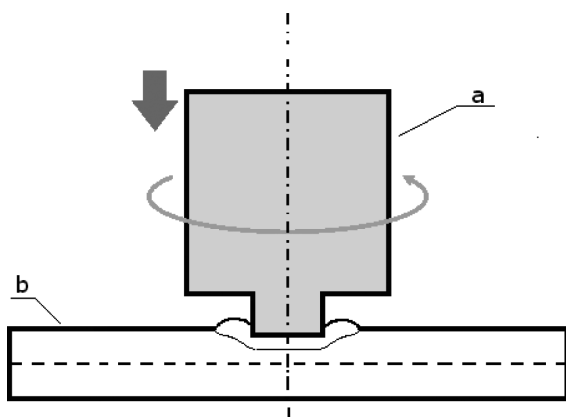

Fig. 1. Scheme of friction stir spot welding – plunge phase: a) tool, b) welded materials

Without knowledge of the effect of friction conditions and tool geometry on the process course, it is impossible to design the tool and the required properties of the weld. Although the idea of friction stir welding is simple, in fact, the process pose a complex thermal and mechanical problem involving numerous interactions [1]. In order to a better understanding of the process many experiments are carried out [2, 3, 4, 5]. Finite element method is mainly used in the numerical simulations of FSSW. The Coulomb friction model is implemented mostly [6, 7, 8].

Heat plays the main role in the FSSW process. Friction between the tool and the welded materials is one of two of its sources. Friction depends on many factors [9]. Apart from the assumed frictional model the FSSW process parameters such as: rotational speed of the tool, depth and speed of penetration and stirring time have a significant influence on the amount of frictional heat. The tool shape and its dimensions (diameter and height of the pin, shoulder diameter and inclination angle of the concave shoulder surface) also play an important role in the process course. The process parameters should be chosen so as to ensure plasticity of welded materials. In this paper, the influence of some geometric tool parameters on frictional heat generation in friction stir spot welding is analysed.

2. Process model

Temperature is determined on the basis of the transient heat conduction equation:

$$\rho c \frac{dT}{dt} = \nabla (k \nabla T) + q \quad (1)$$

where: ρ – density (kg/m^3), c – specific heat ($\text{J/kg } ^\circ\text{C}$), T – temperature ($^\circ\text{C}$), k – thermal conductivity ($\text{W/m } ^\circ\text{C}$), q – capacity of the volumetric inner heat source (W/m^3).

The initial temperature of the tool and the welded materials is $T_o = 25^\circ\text{C}$.

As it was mentioned before, generated heat is a result of friction between the tool and the welded materials, and plastic deformation occurring in the welded materials. According to [10] it was assumed that 95% of frictional heat is transmitted to the welded parts, and 5% to the tool. 100% of plastic strain energy is converted to heat.

A thermo-plastic material model was used for modelling the friction stir spot welding process of 6061-T6 aluminium alloy. The mechanical properties of the alloy are presented in TABLE 1 [11].

TABLE 1

Properties of 6061-T6 aluminium alloy depending on temperature [11]

Temperature ($^\circ\text{C}$)	25.0	37.8	93.3	148.9	204.4	260.0	315.6	371.1	426.7
Yield point (MPa)	276.0	274.4	264.4	248.2	218.6	159.7	66.2	34.5	17.9
Young's modulus (GPa)	68.90	68.54	66.19	63.09	59.16	53.99	47.48	40.34	31.72

3. Numerical simulation

The numerical simulation was carried out using ADINA System v.8.8.0 [12]. The problem was considered as an axisymmetric one. A part of finite element mesh is shown in Fig. 2.

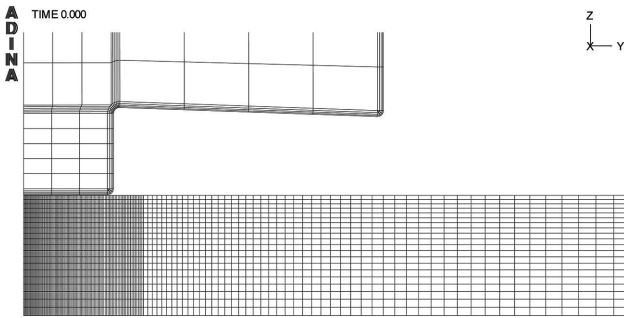

Fig. 2. Finite element mesh

The model consist of deformable material and a rigid stir tool. The tool consists of two parts: the pin and the shoulder. The tool is inserted into the welded material with a constant displacement $\Delta w = 5 \cdot 10^{-6}$ m and a rotational speed $\omega = 600$ rpm.

The welded material was modelled as a disc with diameter of 0.05 m and thickness of 0.002 m.

The basic tool parameters are given in Fig. 3. A pin radius is of $r_t = 0.0015$ m and its height is $h_t = 0.0013$ m. The shoulder has a diameter of 0.006 m and a height of 0.003 m. α cone angle changes from 0° to 6° . The following data: $k = 167$ W/m $^\circ$ C, $c = 896$ J/kg $^\circ$ C, $\rho = 2700$ kg/m 3 , coefficient of heat expansion $\alpha = 22$ μ m/m $^\circ$ C were assumed in the thermal model of 6061-T6 aluminium alloy.

It was also assumed that the tool is made of AISI H13 steel with the following data: $k = 25$ W/m $^\circ$ C, $c = 460$ J/kg $^\circ$ C, $\rho = 7760$ kg/m 3 , coefficient of heat expansion $\alpha = 10.4$ μ m/m $^\circ$ C, $E = 210$ GPa, $\sigma_{pl} = 1520$ MPa, $\nu = 0.33$.

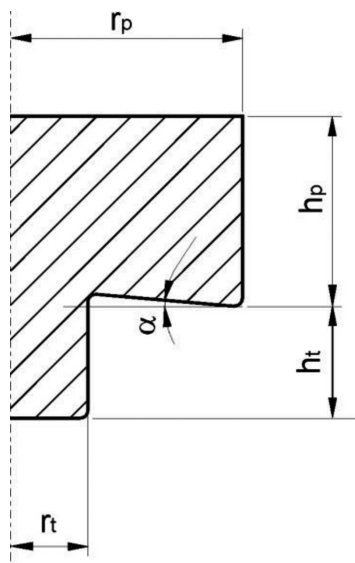

Fig. 3. Basic shape of the tool

The Coulomb frictional model was implemented. The friction coefficient varies with temperature as follows [13]:

$$\mu = \begin{cases} B_2 & \text{for } T < B_1 \\ B_2 \frac{B_3 - T}{B_3 - B_1} + B_4 \frac{T - B_1}{B_3 - B_1} & \text{for } T < B_3 \\ B_4 & \text{for } T \geq B_3 \end{cases} \quad (2)$$

where: B_1 and B_3 – limit values of temperature, B_2 and B_4 – values of friction coefficient dependant on instantaneous values of temperature in the contact zone. $B_1 = 150^\circ$ C, $B_2 = 0.3$, $B_3 = 582^\circ$ C, $B_4 = 0.01$ were implemented.

4. Results

The friction stir spot welding is a three-stage process:

- plunging of the rotating tool in the welded materials,
- stirring of the material by the rotating tool, the tool rotates without moving down,
- retracting of the tool.

In the work two first phases are considered.

Temperature fields for the tool with a flat surface of the shoulder ($\alpha = 0^\circ$) at some time steps are shown in Fig. 4. As the tool penetrates the material, frictional heat causes gradual heating of the material. The pin has two surfaces that can generate heat – the tip and the side of the pin. A pin tip surface, a pin side surface and a shoulder tip surface successively get in contact with the upper surface of the welded material.

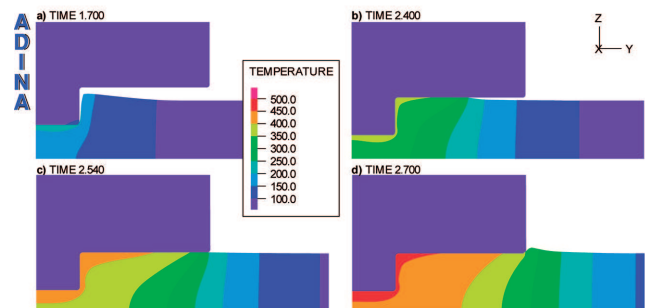

Fig. 4. Temperature distribution: a) $t = 1.70$ s, b) $t = 2.40$ s, c) $t = 2.54$ s, d) $t = 2.70$ s

As it is seen in Fig. 4 the maximum temperature occurs in the welded material located directly below the pin tip surface. The maximum temperature in the welded material for the time step $t = 2.7$ s and for the assumed data is of 465.9° C, Fig. 4d. Because FSSW is the solid-state process the temperature values range from 70% to 90% of melting temperature of welded material. The calculated temperature values are in this range. When the constant value of friction coefficient $\mu = 0.3$ was assumed the maximum temperature was of 678.9° C, much more than melting point of 6061-T6 aluminium alloy, i.e. 582° C [14].

Tool shape, especially a geometry of the pin and shoulder, is one of the basic parameters of the friction stir spot welding process. In the first stage of calculations it was assumed that the pin and the shoulder are the smooth cylinders with flat tip surfaces ($\alpha = 0^\circ$). The influence of ratio of the shoulder radius r_p to the pin radius r_t on the temperature field in the welded

material was analysed. The radius of the shoulder had a constant value $r_p = 0.006$ m. The ratio r_p/r_t varied from 6 ($r_t = 0.001$ m) to 2 ($r_t = 0.031$ m). Fig. 5 shows the temperature field for the selected values of r_p/r_t ratio at $t = 2.6$ s.

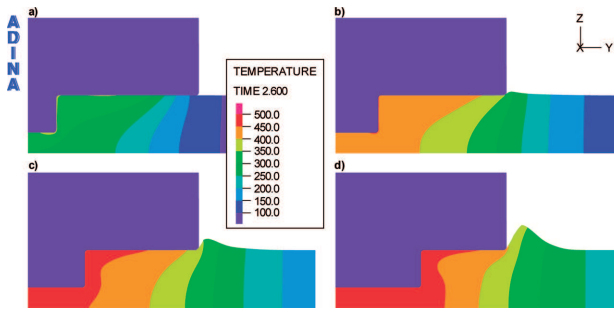

Fig. 5. Temperature distribution at $t = 2.6$ s: a) $r_p/r_t = 6$, b) $r_p/r_t = 4$, c) $r_p/r_t = 3$, d) $r_p/r_t = 2$

The maximum calculated temperature is: $T_{max} = 368.7^\circ\text{C}$ for $r_p/r_t = 6$, $T_{max} = 457.6^\circ\text{C}$ for $r_p/r_t = 4$, and $T_{max} = 486.7^\circ\text{C}$ for $r_p/r_t = 2$. At the beginning of the process only the pin tip surface is in contact with the upper material surface. The bigger the pin radius the broader the contact surface, so if a velocity of tool penetration is constant the frictional heat generation is greater. It also means the greater temperature-rise. Simultaneously, with the increase in pin radius it is possible to observe more intensive material flow and creation the bigger and bigger material rim around the shoulder. The bigger the pin radius the larger pin volume is inserted into the material so the larger volume of the stirred material is pressed out from the tip face of the pin.

An effect of the pin radius on the maximum temperature in the welded material is shown in Fig. 6. It is seen that as long as the tip face of the pin is the only frictional heat source there are significant differences in the temperature courses. It is due to a significant difference in heat generation for the different pin radius. For example, at $t = 1.6$ s: $T_{max} = 164^\circ\text{C}$ for $r_t = 0.001$ m, and $T_{max} = 373^\circ\text{C}$ for $r_t = 0.003$ m. $\Delta T_{max} = 209^\circ\text{C}$. When the shoulder also starts to generate heat the differences decrease. Whatever the size of the pin radius all tool surfaces, which are inserted into the material, participate in the heat generation. Thus, the conditions of heat generation in all cases are similar. In the stirring phase, $t > 2.6$ s, when the tool only rotates, the maximum temperature in the welded material ranges from 455°C to 485°C . $\Delta T_{max} = 30^\circ\text{C}$.

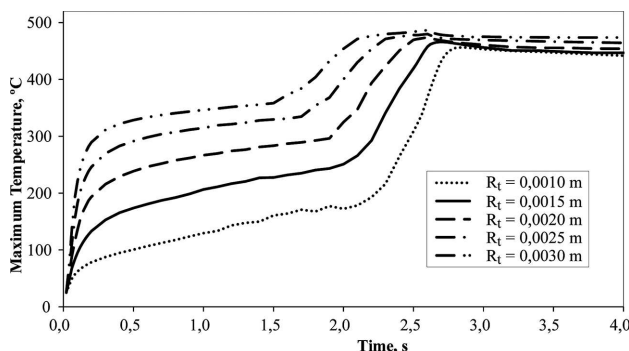

Fig. 6. An influence of the pin radius on maximum temperature in the welded material

The bigger the pin radius the greater amount of heat, and the material being under the pin becomes more soft. Therefore, the material puts less resistance against the tool. For $r_t = 0.001$ m ($r_p/r_t = 6$) $F_{max} = 7.173$ kN and for $r_t = 0.003$ m ($r_p/r_t = 2$) $F_{max} = 4.616$ kN. It means that the decrease in maximum axial force in the plunge state is of 35.6%.

In the second stage of the calculations, the cone face of the shoulder was taken into consideration. The cone angle α (see Fig. 3) takes on values: 0° , 2° , 4° and 6° . In all cases there are: $r_t = 0.0015$ m, $h_t = 0.0013$ m, $r_p = 0.006$ m, and $w = 0.00138$ m (the maximum tool displacement).

The temperature fields for different values of α angle are shown in Fig. 7. The maximum temperature $T_{max} = 465.9^\circ\text{C}$ occurred in the case of the flat face of the shoulder ($\alpha = 0^\circ$) at $t = 2.7$ s. With the increase in angle value the maximum temperature decreases. For $\alpha = 6^\circ$ $T_{max} = 246.7^\circ\text{C}$. Although the temperature distributions (Fig. 7) concern the same phase of tool penetration, when α angles are 4° and 6° only a part of the shoulder tip face is in contact with the welded material. The increase in α angle causes a “pocket” under the shoulder so the material later gets in contact with the shoulder surface, and thus later participates in frictional heat generation.

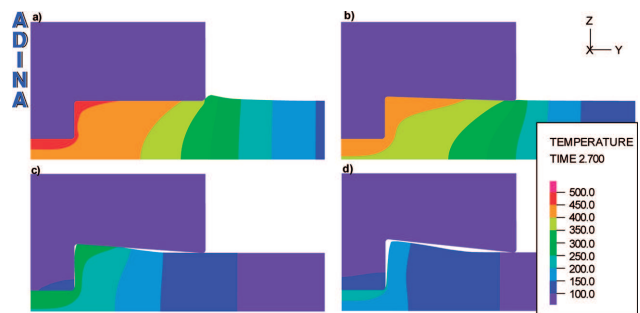

Fig. 7. Temperature distribution at $t = 2.7$ s: a) $\alpha = 0^\circ$, b) $\alpha = 2^\circ$, c) $\alpha = 4^\circ$, d) $\alpha = 6^\circ$

With the increase in α angle and the same other process parameters the maximum axial force F_{max} decreases. $F_{max} = 6.629$ kN for $\alpha = 0^\circ$, and $F_{max} = 2.284$ kN for $\alpha = 6^\circ$. The decrease is of 64.8%. It seems to be very interesting although the improper selection of α angle in relation to the pin height and the depth of its penetration can cause insufficient surface contact between the shoulder and upper material surface (Fig. 7d). As a result a holding-down force is too low and the material will not be stirred enough so the weld strength will decrease.

A change in the maximum temperature versus time for different α angles of the shoulder is shown in Fig. 8. The maximum temperature rises with time. Temperature courses overlap when only the pin tip surface is in contact with welded materials. The differences occur when the shoulder starts to generate frictional heat. The smaller the angle, the faster temperature rise. For $\alpha = 0^\circ$ the change in the growth rate of the maximum temperature is $t \approx 2.0$ s, and for $\alpha = 6^\circ$ it is $t \approx 2.75$ s. In the stirring phase the maximal temperatures equalize. Despite the differences in the shape of the shoulder at the assumed maximal tool displacement the whole surface of the tool takes part in heat generation.

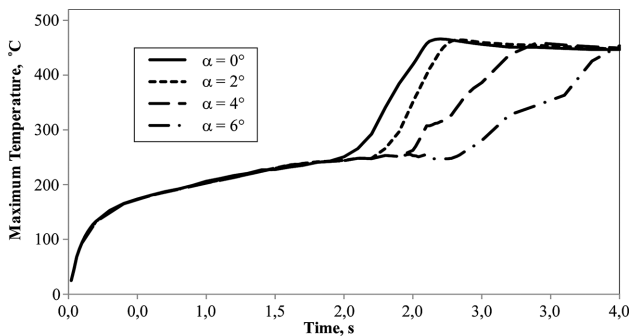

Fig. 8. An influence of α angle on maximum temperature in welded materials

5. Summary

The finite element method was applied for modelling the friction stir spot welding process. The temperature distributions for the selected time steps were determined. The dependence of friction coefficient on the temperature was taken into consideration. It has been shown that, in such a model of friction coefficient the melting points of the welded materials are not exceeded. It is a necessary condition for the process.

The influence of the tool shape (pin radius, inclination angle of shoulder tip surface) on frictional heat generation in the contact zone tool - welded parts was analysed. r_p/r_t ratio affects heating speed and volume of heated material. In the plunge phase, as the pin radius grows the maximum temperature-rise increases. At the same time formation of the bigger rims of the material which flows around the edge of the shoulder are observed.

In the plunge phase, when the concave profile of the shoulder is considered, the maximum axial force applied to the tool decreases. The increase in α angle should be chosen with particular attention. Improper values of α angle in relation to the pin height and penetration depth can cause insufficient surface contact between shoulder and welded material.

The results show how important the tool shape is in modelling of the friction stir spot welding process due to heat generation. This is important, because in the plunge phase

the initial thermo-mechanical conditions are created for the stirring phase of the welded materials.

Acknowledgements

Financial support of Structural Funds in the Operational Programme - Innovative Economy (IE OP) financed from the European Regional Development Fund - Project "Modern material technologies in aerospace industry", Nr POIG.01.01.02-00-015/08-00 is gratefully acknowledged.

REFERENCES

- [1] R.S. Mishra, Scripta Mater. **58**, 325 (2008).
- [2] A. Gerlich, P. Su, T.H. North, J. Mater. Sci. **40**, 6473 (2005).
- [3] S.G. Arul, S.F. Miller, G.H. Kruger, T.-Y. Pan, P.K. Mallick, A.J. Shih, Sci, Technol, Weld. Joi. **13**, 629 (2008).
- [4] Q. Yang, S. Mironov, Y.S. Sato, K. Okamoto, Mat. Sci. Eng. A **527**, 4389 (2010).
- [5] W. Yuan, R.S. Mishra, S. Webb, Y.L. Chen, B. Carlson, D.R. Herling, G.J. Grant, J. Mater. Process. Tech. **211**, 972 (2011).
- [6] M. Awang, V.H. Mucino, Z. Feng, S.A. David, Technical Paper for the Society of Automotive Engineers 2005 World Congress, Detroit (2005).
- [7] S. Mandal, J. Rice, A.A. Elmustafa, J. Mater. Process. Tech. **203**, 411 (2008).
- [8] P. Lacki, Z. Kucharczyk, R.E. Śliwa, T. Gałaczyński, Rudy Metale **57/8**, 524 (2012) in Polish.
- [9] K.J. Colligan, R.S. Mishra, Scripta Mater. **58**, 327 (2008).
- [10] Y.J. Chao, X. Qi, W. Tang, J. Manuf. Sci. E-T Asme. **125**, 138 (2003).
- [11] M. Riahi, H. Nazari, Int. J. Adv. Manuf. Technol. **55**, 143 (2011).
- [12] ADINA-AUI, Version 8.8.0, 1994-2012 ADINA R&D. Inc.
- [13] P. Lacki, Friction modelling in the bulk metal forming processes, Wydawnictwo Politechniki Częstochowskiej, seria Monografie nr 169, Częstochowa 2010 (in Polish).
- [14] <http://asm.matweb.com/search/SpecificMaterial.asp?bassnum=MA6061t6>