

MULTIPLICATIVE METHOD FOR REDUCTION OF BIAS IN INDIRECT DIGITAL MEASUREMENT RESULT

Sergey V. Muravyov, Galina V. Zlygosteva, Valeriy N. Borikov

National Research Tomsk Polytechnic University, Institute of Cybernetics, Department of Computer-aided Measurement Systems and Metrology, Pr. Lenina, 30, 634050 Tomsk, Russia (✉ muravyov@camsam.tpu.ru, +7 3822 417527)

Abstract

The error reduction technique, based on inverse transformation, for a shunt active resistance measurement using an ammeter and voltmeter is considered. When computing a corrected reading only multiplicative operations on two measurement results are used, namely squaring and division. The proposed method allows to increase resistance measurement accuracy by about two orders of magnitude what has been validated by both theoretical and experimental outcomes.

Keywords: bias, error reduction technique, shunt ohmic resistance, indirect measurement.

© 2011 Polish Academy of Sciences. All rights reserved

1. Introduction

In a number of recent publications, see for example [1-3], a positive effect of application of calibration or auto-calibration procedures for correction of measurement chain systematic errors (biases) has been demonstrated. One of the well known ways to obtain a measurement accuracy consists in the use of so-called structural-algorithmic methods [4-6]. In this case the measurement errors are diminished with the help of auxiliary means, such as measurement standards, digital-to-analog converters and switching elements. The aim of this paper is to present a comparatively simple bias correction procedure by the example of active DC resistance indirect digital measurement.

DC resistance is a typical characteristic that is usually examined in a course of precise shunts calibration. Shunt resistors have been extensively used in power electronics, see for instance [7, 8], due to their low cost and relative simplicity, while providing reasonable accuracy. Current-technology precise AC shunts are implemented with rated resistance from 0.00001 to 100 Ohm at currents of 0.005 A through 500 kA to be applied in the 50 Hz to 1 MHz frequency range [9].

Known resistance measurement procedures (e.g., Thompson double bridge; magnetic comparator; compensation methods, etc.) require a standard resistance box to be available [10]. These procedures can be hardly implemented at shunt rated resistance less than 1 Ohm. To some degree, the method proposed in the paper allows to surmount the difficulty.

It is normal practice to use an indirect method for measuring active resistance using an ammeter and voltmeter. The method is based on measurement of the shunt voltage and current and subsequent calculation of the resistance by Ohm's law [11]. The method's accuracy is mainly defined by metrological performance of the measuring instruments used.

In this paper we show how this indirect method accuracy can be considerably increased by means of inverse conversion. The measurement is carried out by a digital voltmeter and ammeter in two stages. In the first step, the measured voltage V and current I are connected to the input of the measuring channel. The measurement results V_1 and I_1 are stored and converted

into analog values, those are measured in the second stage. Then the corrected resistance measurement result is calculated $R_c = \frac{V_1^2 I_2}{V_2 I_1^2}$, where V_2 and I_2 are the second-stage measurement results. Computing the final corrected reading, one uses only multiplicative operations over two measurement results, namely squaring and division. The proposed method allows to increase resistance measurement accuracy by more than two orders of magnitude; in the process, requirements to the voltmeter and ammeter accuracy are reduced.

2. Measurement accuracy enhancement using inverse conversion

The proposed resistance measurement method is based on the inverse conversion technique for a bias correction described in [12], which will be shortly discussed in this section.

For the description of a measuring chain transfer function we will use the following simple model:

$$y = x(1 + \gamma) = x\left(1 + \gamma_1 + \gamma_2\right) = x\left(1 + \frac{\Delta_0}{x} + \gamma_2\right), \quad (1)$$

where: x is the measurand, y is the measurement result, γ is the initial relative error, $\gamma_1 = \frac{\Delta_0}{x}$ is the relative additive error, Δ_0 is the absolute additive error, and γ_2 is the relative multiplicative error.

Fig. 1 shows a diagram characterizing the error correction method.

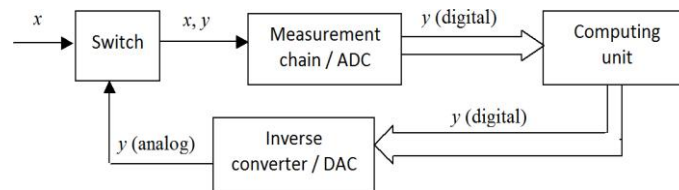

Fig. 1. Error correction method based on inverse conversion

The measurement is conducted in two stages in the following way, see Fig. 1. In the first step, the measurand x is connected to the input of the measuring channel that is generally an analog-to-digital converter (ADC). The digital code of the measurement result $y_1 = x(1 + \gamma_1 + \gamma_2)$ is stored in the computing unit and applied to the inverse converter unit that is generally a digital-to-analog converter (DAC), on the output of which there is the analog value of y_1 . In the second step, by means of the switch, the input of the measuring channel is connected to the value obtained at the inverse converter output. The measuring chain output is:

$$y_2 = x(1 + \gamma_1 + \gamma_2) \left(1 + \frac{\gamma_1}{1 + \gamma_1 + \gamma_2} + \gamma_2\right).$$

Then the computing unit calculates the corrected measurement result:

$$y_c = \frac{y_1^2}{y_2} = \frac{x(1 + \gamma_1 + \gamma_2)^2}{1 + 2\gamma_1 + 2\gamma_2 + \gamma_1\gamma_2 + \gamma_2^2}.$$

Bringing the expression obtained for y_c to the canonical form (1) we have:

$$y_c = x \left(1 + \frac{(1 + \gamma_1 + \gamma_2)^2}{1 + 2\gamma_1 + 2\gamma_2 + \gamma_1\gamma_2 + \gamma_2^2} - 1 \right) =$$

$$= x \left(1 + \frac{\gamma_1(\gamma_1 + \gamma_2)}{(1 + \gamma_1 + \gamma_2)^2 - \gamma_1(\gamma_1 + \gamma_2)} \right) = x \left(1 + \frac{\gamma_1\gamma}{(1 + \gamma)^2 - \gamma_1\gamma} \right). \quad (2)$$

The effect of considerable measurement error reduction as a result of the correction is demonstrated in Fig. 2.

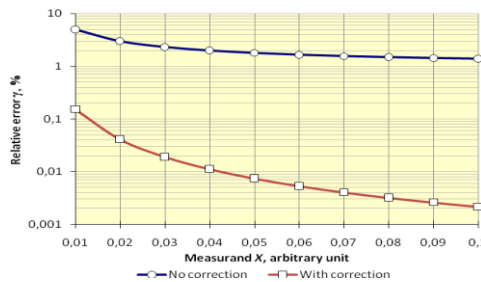

Fig. 2. Dependence of theoretical relative measurement error on x .

As it can be seen from formula (2), in the corrected measurement result the initial relative error γ has been multiplied by the value $\frac{\gamma_1}{(1 + \gamma_1 + \gamma_2)^2 - \gamma_1(\gamma_1 + \gamma_2)}$.

Let us introduce designation $\psi = \frac{\gamma}{\gamma_c}$, where γ_c is an error of the corrected measurement result. Then from formula (2) follows the validity of the expression:

$$\frac{\gamma_1}{(1 + \gamma_1 + \gamma_2)^2 - \gamma_1(\gamma_1 + \gamma_2)} = \frac{1}{\psi}. \quad (3)$$

Taking notice that the denominator in the left hand part of formula (3) is practically equal to 1 as $\gamma_1, \gamma_2 \ll 1$, we obtain $\gamma_1 \approx 1/\psi$. It means that under the proposed technique the error reduction is practically independent of the initial relative multiplicative error. The corrected error γ_c is a factor of ψ lower, where ψ varies inversely as the initial relative additive error. For example, if the relative additive error is 0.01, the corrected result error will be a factor of 100 lower than the initial relative error.

Thus, by means of the inverse conversion method, a correction of both multiplicative and additive errors is possible.

It is well known that the accuracy of the described inverse conversion technique for a bias correction as well as of all similar methods depends on a fraction of random uncertainties [4-6] and can only be applied if the random component is essentially lower than the systematic error. Fortunately, in practice, this situation is not unusual [13]. In the remainder of this paper we suppose that the biases prevail and random errors can be neglected.

Consider now the method of shunt active resistance measurement on the basis of the inverse conversion approach.

3. Shunt active resistance measurement

Block diagram of the measurement system is shown in Fig. 3.

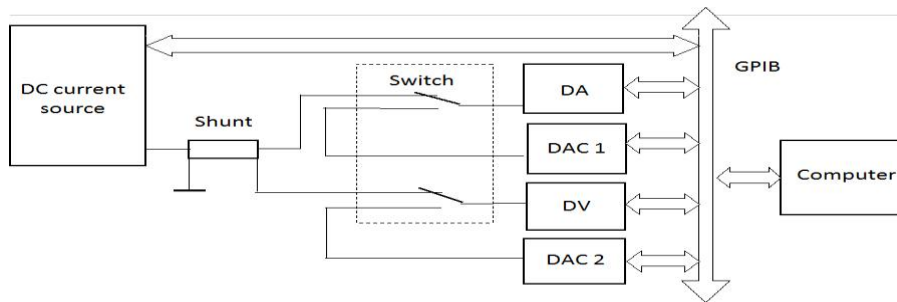

Fig. 3. Block diagram of the shunt active resistance measurement.

Shunt resistance is measured in two stages as follows. In the *first stage*, a signal from the DC source is applied to the shunt under measurement. The shunt has a transfer coefficient R , the switch connects the shunt current output to the digital ammeter (DA), and the shunt potential output – to the digital voltmeter (DV).

Measurement outcomes of current I_1 and voltage V_1 , accounting (1), are as follows:

$$\begin{cases} I_1 = I(1 + \gamma_1^a + \gamma_2^a) \\ V_1 = V(1 + \gamma_1^v + \gamma_2^v) \end{cases}, \quad (4)$$

where: I is the current source output signal; V is the voltage across the shunt; γ_1^a , γ_2^a are multiplicative and additive errors of the DA; γ_1^v , γ_2^v are multiplicative and additive errors of the DV. The digital codes of the measurement results I_1 and V_1 are stored in the memory of the computer and applied to the inputs of DAC1 and DAC2 as current and voltage appropriately.

In the *second stage*, by means of the switch, signals from DAC1 and DAC2 are applied to DA and DV, at the output of those one can obtain the following values:

$$\begin{cases} I_2 = I(1 + \gamma_1^a + \gamma_2^a) \left(1 + \frac{\gamma_1^a}{1 + \gamma_1^a + \gamma_2^a} + \gamma_2^a \right) (1 + \delta_1) \\ V_2 = V(1 + \gamma_1^v + \gamma_2^v) \left(1 + \frac{\gamma_1^v}{1 + \gamma_1^v + \gamma_2^v} + \gamma_2^v \right) (1 + \delta_2), \end{cases} \quad (5)$$

where: δ_1 and δ_2 are relative errors of DAC1 and DAC2 correspondingly.

The codes of results I_2 and V_2 are memorized in the computer and used to calculate corrected results of current and voltage measurements:

$$\begin{cases} I_c = \frac{I_1^2}{I_2} = \frac{I}{1 + \delta_1} \left(1 + \frac{\gamma_1^a \gamma^a}{(1 + \gamma^a)^2 - \gamma_1^a \gamma^a} \right) \\ V_c = \frac{V_1^2}{V_2} = \frac{V}{1 + \delta_2} \left(1 + \frac{\gamma_1^v \gamma^v}{(1 + \gamma^v)^2 - \gamma_1^v \gamma^v} \right) \end{cases}. \quad (6)$$

The shunt resistance R_c is determined using the corrected values of current and voltage I_c and V_c :

$$R_c = \frac{V_c}{I_c} = \frac{V}{I} \cdot \frac{1 + \frac{\gamma_1^v \gamma^v}{(1 + \gamma^v)^2 - \gamma_1^v \gamma^v}}{1 + \frac{\gamma_1^a \gamma^a}{(1 + \gamma^a)^2 - \gamma_1^a \gamma^a}} \cdot \frac{1 + \delta_1}{1 + \delta_2}. \quad (7)$$

It is evident from formula (7) that as the additive errors γ_1^v and γ_1^a tend to zero, i.e., $\gamma^v \rightarrow \gamma_2^v$, $\gamma^a \rightarrow \gamma_2^a$, the sought resistance value $R_c \rightarrow \frac{V(1 + \delta_1)}{I(1 + \delta_2)}$ and is virtually defined by the accuracy of barely DAC1 and DAC2. As soon as the condition $\delta_1 \approx \delta_2$ can be considered to be fulfilled in practice, the error of the shunt resistance measurement can be considerably reduced.

The final resistance measurement relative error, accounting expressions (6) and (7), is defined by formula

$$\gamma_c = \frac{\frac{\gamma_1^v \gamma^v}{(1 + \gamma^v)^2 - \gamma_1^v \gamma^v} + \frac{\gamma_1^a \gamma^a}{(1 + \gamma^a)^2 - \gamma_1^a \gamma^a}}{1 + \frac{\gamma_1^a \gamma^a}{(1 + \gamma^a)^2 - \gamma_1^a \gamma^a}}. \quad (8)$$

The described method of resistance measurement is confirmed by a patent on an utility model of Russian Federation [14].

4. Proposed method experimental validation

With the aim of an experimental check-up of the proposed method of the bias correction ohmic resistance measurements were carried out with and without the correction procedure.

Two inexpensive 4.5-digit multimeters V7-22A manufactured in the Russian Federation acted as ammeter and voltmeter. The principle of the multimeter's ADC operation is based on dual slope integration. The multimeter is characterized by a random error that is considerably (namely, at least by a factor of 55) lower than a systematic one. Hence, in the experimental researches we suppose the random error to be neglected (see the last but one paragraph of Section 2). The instrument specifications are reduced in Table 1.

The limits of relative additive γ_1 and multiplicative γ_2 errors of this multimeter both in current and voltage measurements are standardized in the following way: $\gamma_1 = b x_r / x$ %, $\gamma_2 = a$ %, where x_r is the measurement range.

Table 1. Specifications of the multimeter V7-22A.

Measurand	Measurement range	Accuracy = $\pm(a + b \cdot x_r / x)$ %
DC voltage	0.2, 2, 20, 200 V	$\pm(0.15 + 0.2 \cdot x_r / x)$ %
	1000 V	$\pm(0.15 + 0.4 \cdot x_r / x)$ %
DC current	0.2, 2, 20, 200 mA	$\pm(0.25 + 0.25 \cdot x_r / x)$ %
	2 A	$\pm(0.25 + 0.3 \cdot x_r / x)$ %

Multivalued measure of electrical resistance R4831 (also manufactured in the Russian Federation) of the accuracy class $0.02/2 \cdot 10^{-6}$ has been used as an object under test. The Fluke

5520 A calibrator was applied as a current source. We did not use DACs as shown in Fig. 3. Instead of this, during the second stage of measurement, setting up analog current and voltage signals being equal to the first stage measurement results has been made by means of the programmable Fluke 5520 A calibrator.

Comparison of no correction and with correction measurement accuracies has been done by computing deviations of measured resistance values R from nominal ones R_n . Two series of measurements were conducted: for nominal resistances 0.1, 0.2, ..., 1.0 Ohm and 0.01, 0.02, ..., 0.1 Ohm. Random uncertainty was absent in these measurements, therefore, for each of the rated resistance values, single measurements were carried out. All the measurements were made under the rated current $I_n = 100$ mA.

Thus, for voltage measurements the range 0.2 V was used and for current – the range 200 mA of the multimeter V7-22A. Then, from Table 1, we have the following limits of relative additive and multiplicative errors for voltage and current measurements appropriately:
 $\gamma_1^v = \frac{0.2 \cdot V_r}{V} = \frac{0.2 \cdot 0.2}{V} = \frac{0.04}{V} \%$; $\gamma_2^v = 0.15 \%$; $\gamma_1^a = \frac{0.25 \cdot I_r}{I} = \frac{0.25 \cdot 0.2}{I} = 0.5 \%$; and $\gamma_2^a = 0.25 \%$.

The measurement results obtained for the scale $R_n = 0.1$ through 1.0 Ohm are reduced to Table 2 and presented in Fig. 4. Graph 1 in Fig. 4 shows behavior of the limit of resistance measurement relative error without correction built by formula:

$$\gamma = \frac{\gamma^v + \gamma^a}{1 + \gamma^a} = \frac{\gamma_1^v + \gamma_2^v + \gamma_1^a + \gamma_2^a}{1 + \gamma_1^a + \gamma_2^a} = \frac{0.04}{V} + 0.9 = \frac{0.04 + 0.9V}{1.0075} = \frac{0.04 + 0.9V}{1.0075V} \quad (9)$$

Graph 2 in Fig. 4 showing behavior of the limit of resistance measurement relative error with correction is built by formula (8).

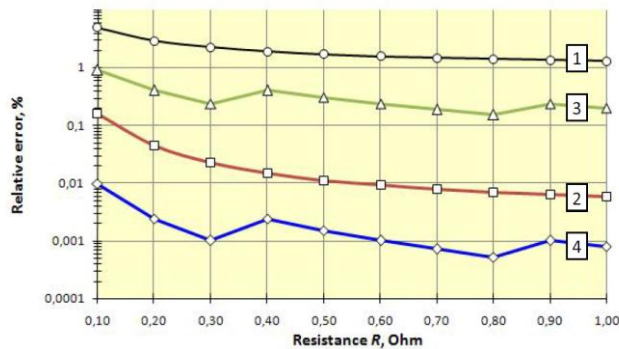

Fig. 4. Dependency of the relative error on R for $R_n = 0.1$ through 1.0 Ohm: error limit – without (1) and with (2) correction; and experimental error – without (3) and with (4) correction.

Table 2. Experimental data for $R_n = 0.1$ through 1.0 Ohm: $I_1 = 100.1$, $I_2 = 100.2$, $I_c = 100.0001$ mA for all R_n .

R_n , Ohm	Raw data		V_1 , V	V_2 , V	V_c , V	R_c , Ohm	R_{ccs} Ohm	γ , %	γ_{cs} %	γ_{cs} %	γ_{ccs} %
	V_1 , V	V_2 , V									
0.1	0.0159	0.0160	0.0101	0.0102	0.010001	0.100899	0.100010	4.8635	0.1570	0.8991	0.0097
0.2	0.0259	0.0260	0.0201	0.0202	0.020000	0.200799	0.200005	2.8784	0.0449	0.3996	0.0024
0.3	0.0359	0.0360	0.0301	0.0302	0.030000	0.300699	0.300003	2.2167	0.0229	0.2331	0.0010
0.4	0.0460	0.0462	0.0402	0.0404	0.040001	0.401598	0.400010	1.8859	0.0149	0.3996	0.0024
0.5	0.0560	0.0562	0.0502	0.0504	0.050001	0.501499	0.500007	1.6873	0.0112	0.2997	0.0015
0.6	0.0660	0.0662	0.0602	0.0604	0.060001	0.601399	0.600006	1.5550	0.0091	0.2331	0.0010
0.7	0.0760	0.0762	0.0702	0.0704	0.070001	0.701299	0.700005	1.4605	0.0078	0.1855	0.0007
0.8	0.0860	0.0862	0.0802	0.0804	0.080000	0.801199	0.800004	1.3896	0.0069	0.1499	0.0005
0.9	0.0961	0.0964	0.0903	0.0906	0.090001	0.902098	0.900009	1.3344	0.0063	0.2331	0.0010
1.0	0.1061	0.1064	0.1003	0.1006	0.100001	1.001998	1.000008	1.2903	0.0059	0.1998	0.0008

For all R_n current measurement results were as follows: $I_1 = 100.1$ mA, $I_2 = 100.2$ mA, and $I_c = 100.0001$ mA.

When the resistance R_n of multivalued measure R4831 was set to 0, the voltmeter reading was 0.0058 V (evidently, due to influence of transient contact resistances and also of inter-connecting lines). Therefore, the voltage readings V_1 and V_2 were obtained from the raw readings (in the second and third left-hand columns) by subtracting the allowance 0.0058 V.

In Table 2, values of $R_e = \frac{V_1}{I_1}$ corresponds to no correction resistance measurement; values

$$R_{ec} = \frac{V_1^2 I_2}{V_2 I_1^2}$$

show corrected resistance measurement results.

The behavior of the resistance experimental non-corrected and corrected measurements is shown in Fig. 4 (curves 3 and 4 appropriately). These graphs are plotted using expressions $\gamma_e = \frac{|R_n - R_e|}{R_n} \cdot 100\%$ and $\gamma_{ec} = \frac{|R_n - R_{ec}|}{R_n} \cdot 100\%$.

As it can be seen from Table 2, in spite of a restricted resolution of multimeter V7-22A, the proposed error correction method works and provides enhancement of resistance measurement accuracy by no less than two orders of magnitude, what is in correspondence with the effect predicted by expression (8).

It follows from the experimental research (see Table 3) that the voltage V_2 can vary only in a narrow corridor defined by the expression

$$V_1 - V_n = V_2 - V_1, \tag{10}$$

where: V_n is the rated voltage. That is why the presence of a random error can cancel a positive effect of the proposed method. However, if a systematic error prevails (what is the case of this experimental research), the method works well.

Table 3. Valid combinations of V_1 and V_2 and corresponding experimental corrected error γ_{ec} as revealed from experimental data (see Table 2).

$(V_1 - V_n), V$	$R_n = 0.1 \text{ Ohm } (V_n = 0.01 \text{ V})$			$R_n = 1 \text{ Ohm } (V_n = 0.1 \text{ V})$		
	V_1, V	V_2, V	$\gamma_{ec}, \%$	V_1, V	V_2, V	$\gamma_{ec}, \%$
-0.0002	0.0098	0.0096	0.04157	0.0998	0.0996	0.0003
-0.0001	0.0099	0.0098	0.0101	0.0999	0.0998	0
0	0.0100	0.0100	0.0001	0.1000	0.1000	0.0001
0.0001	0.0101	0.0102	0.0097	0.1001	0.1002	0
0.0002	0.0102	0.0104	0.03836	0.1002	0.1004	0.0003
0.0003	0.0103	0.0106	0.08481	0.1003	0.1006	0.0008

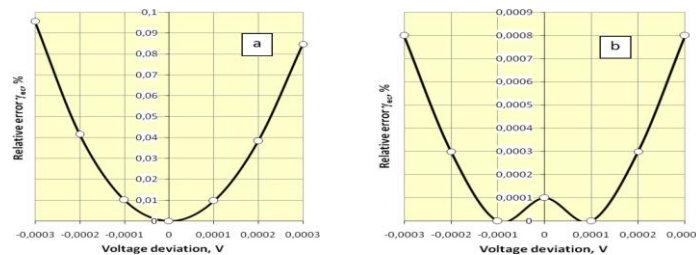

Fig. 6. Dependence of the experimental corrected error γ_{ec} on voltage deviation $V_1 - V_n$ for the scale $R_n = 0.1$ through 1.0 Ohm: (a) – the case of $R_n = 0.1$ Ohm and $V_n = 0.01$ V; (b) – the case of $R_n = 1$ Ohm and $V_n = 0.1$ V.

Table 3 and Fig. 6 show how the experimental corrected error γ_{ce} depends on the voltage deviation $V_1 - V_n = V_2 - V_1$ for the beginning of scale $R_n = 0.1$ Ohm and $V_n = 0.01$ V (Fig. 6, a) and for the end of scale $R_n = 1$ Ohm and $V_n = 0.1$ V (Fig.6, b). One can see that the maximal correction is reached where $|V_1 - V_n| = 0 \dots 0.0001$ V.

The measurement results obtained for the scale $R_n = 0.01$ through 0.1 Ohm are reduced to Table 4 and presented in Fig. 7. As earlier, the allowance 0.0058 V was applied. As compared with the previous case (Table 2 and Fig. 4), the correction effect is lower but considerable enough: almost two orders of magnitude.

Table 4. Experimental data for $R_n = 0.01$ through 0.1 Ohm: $I_1 = 100.1$, $I_2 = 100.2$, $I_c = 100.0001$ mA for all R_n .

R_n , Ohm	Raw data		V_1 , V	V_2 , V	V_c , V	R , Ohm	R_c , Ohm	γ , %	γ_c , %	γ_e , %	γ_{ec} , %
	V_1 , V	V_2 , V									
0.01	0.0069	0.0070	0.0011	0.0012	0.001008	0.010989	0.010083	40.5955	8.9078	9.8901	0.8332
0.02	0.0079	0.0080	0.0021	0.0022	0.002005	0.020979	0.020045	20.7444	2.8754	4.8951	0.2272
0.03	0.0089	0.0090	0.0031	0.0032	0.003003	0.030969	0.030031	14.1274	1.4194	3.2301	0.1041
0.04	0.0099	0.0100	0.0041	0.0042	0.004002	0.040959	0.040024	10.8189	0.8473	2.3976	0.0594
0.05	0.0109	0.0110	0.0051	0.0052	0.005002	0.050949	0.050019	8.8337	0.5642	1.8981	0.0384
0.06	0.0119	0.0120	0.0061	0.0062	0.006002	0.060939	0.060016	7.5103	0.4036	1.5651	0.0268
0.07	0.0129	0.0130	0.0071	0.0072	0.007001	0.070929	0.070014	6.5650	0.3036	1.3272	0.0197
0.08	0.0139	0.0140	0.0081	0.0082	0.008001	0.080919	0.080012	5.8561	0.2371	1.1489	0.0151
0.09	0.0149	0.0150	0.0091	0.0092	0.009001	0.090909	0.090011	5.3047	0.1907	1.0101	0.0120
0.10	0.0159	0.0160	0.0101	0.0102	0.010001	0.100899	0.100010	4.8635	0.1570	0.8991	0.0097

5. Conclusions

Under the condition that random measurement errors can be neglected, application of the bias correction based on inverse conversion allows to considerably increase the accuracy of measurement – by more than two orders of magnitude, what has been validated by both theoretical and experimental outcomes.

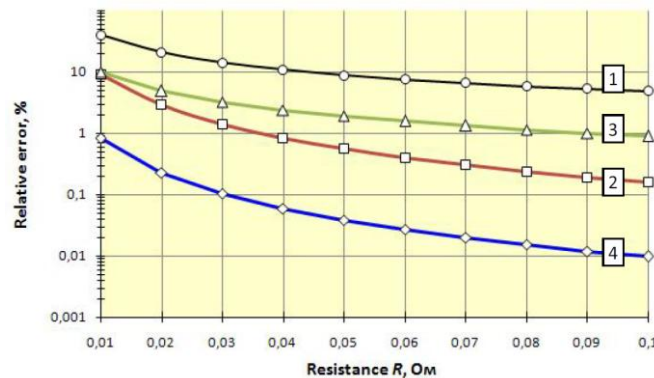

Fig. 7. Dependency of relative error on R for $R_n = 0.01$ through 0.1 Ohm: error limit – without (1) and with (2) correction; and experimental error – without (3) and with (4) correction.

As far as, when computing the corrected measurement result, only multiplicative operations over two measured values are used – namely, squaring and division – the corrected error is independent of the sign of the systematic bias and always decreased by the absolute value.

The given method can be used for calibration of shunts [14]. At that, there is no necessity to use DACs which are useful in case of automatic measurements, and, during the second stage of measurement, one can set up analog current and voltage signals being equal to the first stage measurement results by means of variable current and voltage sources.

Acknowledgements

This work was supported by the Ministry of Education and Science of Russian Federation under grant No. NK-566P/13 in the area "Creation of electronic component base" in the framework of the measure 1.2.1 "Conducting researches by scientific groups under doctors of sciences supervision" of the Federal Target Program "Scientific and scientific-pedagogical personnel of innovative Russia" (2009-2013).

References

- [1] Quaresma, H.J.Q., Silva, A., Serra, A.C. (2003). Improving dynamic resistance and differential capacitance measurement of active devices. In *Proceedings of the XVII IMEKO World Congress*. Dubrovnik, Croatia, 1, 959-962.
- [2] Nadi, M., Margo, C., Kouider, M., Prado, J., Kourtiche, D. (2008). Embedded system design and implementation of standard auto-calibrated measurement chain. *International Journal on Smart Sensing and Intelligent Systems*, 1(1), 21-33.
- [3] Taymanov, R., Sapozhnikova, K., Druzhinin I. (2011). Sensor Devices with Metrological Self-Check. *Sensors & Transducers Journal*, 10(2), 30-45.
- [4] Bromberg, E.M., Kulikovskiy, K.L. (1978). *Test methods for measurement accuracy improvement*. Moscow: Energija. (in Russian).
- [5] Aliev, T.M., Ter-Khachaturov, A.L., Shekikhanov, A.M. (1986). *Iteration methods for measurement accuracy improvement*. Moscow: Energoatomizdat. (in Russian)
- [6] Piotrowski, J. (1992). *Theory of physical and technical measurement*. Amsterdam: Elsevier.
- [7] Ziegler, S., Woodward, R.C., Iu, H.H.C., Borle, L.J. (2009). Current Sensing Techniques: A Review. *IEEE Sensors Journal*, 9(4), 354-376.
- [8] Muravyov, S.V., Borikov, V.N., Natalinova, N.M. (2009). A Computer System: Measurement of Welding Surge Current. *Measurement & Control*, 42(2), 44-47.
- [9] Kawamura, T., Haginomori, E., Goda, Y., Nakamoto, T. (2007). Recent Developments on High Current Measurement Using Current Shunt. *Transactions on Electrical and Electronic Engineering*, 2, 516-522.
- [10] Regtien, P.P.L. (2005). *Measurement Science for Engineers*. London: Kogan Page Science.
- [11] *Achieving Accurate and Reliable Resistance Measurements in Low Power and Low Voltage Applications*. (2004). White Paper. Keithley Instruments, Inc.
- [12] Muravyov, S.V. (2000). Model of procedure for measurement result correction. In *Proceedings of the XVI IMEKO World Congress*. Vienna, Austria, 5, 135-139.
- [13] *NIST/SEMATECH e-Handbook of Statistical Methods*, 2. Measurement Process Characterization, 2.5. Uncertainty analysis, <http://www.itl.nist.gov/div898/handbook/mpc/section5/mpc5.htm>, retrieved 12.05.2011.
- [14] Muravyov, S.V., Borikov, V.N., Natalinova, N.M. (2009). Arrangement for shunts calibration. Patent on utility model no. 80585 (Russian Federation). *Bull.*, (4). (in Russian)