

# Multiple soft fault diagnosis of nonlinear circuits using the fault dictionary approach

S. HAŁGAS\*

Department of Electrical, Electronic Computer and Control Engineering,  
 Technical University of Łódź, 18/22 Stefanowskiego St., 90-924 Łódź

**Abstract.** The paper deals with a multiple fault diagnosis of DC transistor circuits with limited accessible terminals for measurements. An algorithm for identifying faulty elements and evaluating their parameters is proposed. The method belongs to the category of simulation before test methods. The dictionary is generated on the basis of the families of characteristics expressing voltages at test nodes in terms of circuit parameters. To build the fault dictionary the  $n$ -dimensional surfaces are approximated by means of section-wise piecewise-linear functions (SPLF). The faulty parameters are identified using the patterns stored in the fault dictionary, the measured voltages at the test nodes and simple computations. The approach is described in detail for a double and triple fault diagnosis. Two numerical examples illustrate the proposed method.

**Key words:** fault diagnosis, fault dictionary, analog circuits, multiple faults.

## 1. Introduction

The fault diagnosis of analog circuits, especially nonlinear, is an important and still open problem. During the last decades many methods were made to detect different types of faults (soft/hard, single/multiple), in different types of circuits and with a different access to their interior [1–10] have been developed. If circuit simulations take place before the testing process, the diagnosis method is classified as the simulation-before-test (SBT) approach. Methods based on a fault dictionary belong to this group. When having measurements at accessible test points and comparing them with the information stored in the dictionary the faulty elements can be identified and their parameters can be evaluated. The crucial point of the approach is building a fault dictionary. The fundamental works in this area refer to a location of a single catastrophic fault in DC circuits. The large computing power is needed to build the fault dictionary for the multiple hard fault diagnosis. Using the neural network or the fuzzy logic concept enables us to locate parametric faults. In paper [7] a method belonging to SBT category was developed and a original procedure for building a fault dictionary was presented. A key point of the procedure is tracing characteristics which express voltages at the test nodes in terms of resistances considered as possibly faulty using a SPICE-oriented approach. To generate the fault dictionary the characteristics are approximated using piecewise-linear functions. On post test-stage it is required to execute certain calculations to locate faulty elements and estimate their values.

The proposed method, belongs also to the SBT group of methods and it allows the detection of multiple soft faults in nonlinear DC circuits. To build the fault dictionary the  $n$ -dimensional surfaces are approximated by means of section-

wise piecewise-linear functions (SPLF) [11]. The approach is described in detail for the double and triple fault diagnosis. The proposed method has been implemented and tested using several electronic circuits with limited accessible terminals for measurement.

## 2. Section-wise piecewise-linear representation of $n$ -dimensional surfaces

In [11] a closed form analytical formula for representing  $n$ -dimensional surfaces and scalar functions of  $n$  variables  $f(x_1, x_2, \dots, x_n)$  was presented. The representation is piecewise-linear over each cross-section in  $\mathbb{R}^n$  obtained by freezing any combination on  $n - 1$  of the  $n$  coordinates. It agrees with the conventional piecewise-linear representation for  $n = 1$  (function of one variable), but for  $n \geq 2$  is at least quadratic. For example if  $n = 3$  then in the representation appear all product term combinations such as:  $x_1, x_1x_2, x_1x_2x_3, \dots$ . The coefficients of the representation can be easily computed using the formulae given in [11] and repeated below.

Let us consider the special case of this representation concerning the continuous single-valued function of one variable  $f(x_1)$ . With such functions we deal in single fault diagnosis. We label the segments of  $f(x_1)$  from 0 (leftmost segment) through  $N$  and denote the slope of  $j$ -th segment by  $m_j$ . Any piecewise-linear function with  $N$  breakpoints  $x_1^{(1)} < x_1^{(2)} < \dots < x_1^{(N)}$  and leftmost point  $x_1^{(0)}$  (rightmost point  $x_1^{(N+1)}$ ) lying on a straight line extending to  $-\infty$  ( $+\infty$ ) can be represented uniquely using the following formula

\*e-mail: stanislaw.halgas@p.lodz.pl

$$f(x_1) = a_0 + a_1 x_1 + \sum_{j=1}^N (b_j |x_1 - x_1^{(j)}|), \quad (1)$$

where the coefficients are given by:

$$a_1 = \frac{1}{2}(m_0 + m_N), \quad (2)$$

$$b_j = \frac{1}{2}(m_j - m_{j-1}), \quad j = 1, \dots, N, \quad (3)$$

$$a_0 = f(0) - \sum_{j=1}^N (b_j |x_1^{(j)}|). \quad (4)$$

The piecewise-linear characteristics expressing node voltages (or the current of bias source) in terms of the circuit parameters can be stored in the fault dictionary and used to a single fault diagnosis [7].

Let us consider a single-valued continuous function of two variables  $f(x_1, x_2)$ . We assume that for given  $x_2^i$  ( $i = 1, \dots, N_2$ ) function  $f(x_1, x_2^i)$  has  $N_1$  breakpoints  $x_1^{(1)}(x_2^i) < x_1^{(2)}(x_2^i) < \dots < x_1^{(N_1)}(x_2^i)$  and  $N_1 + 1$  segments with the slopes  $m_0(x_2^i), \dots, m_{N_1}(x_2^i)$ . The function  $f(x_1, x_2)$  can be described by the following section-wise piecewise-linear canonical representation

$$\begin{aligned} f(x_1, x_2) &= \\ &= a_0(x_2) + a_1(x_2) x_1 + \sum_{j=1}^{N_1} (b_j(x_2) |x_1 - x_1^{(j)}(x_2)|), \end{aligned} \quad (5)$$

where:

$$a_1(x_2) = \frac{1}{2}(m_0(x_2) + m_{N_1}(x_2)), \quad (6)$$

$$b_j(x_2) = \frac{1}{2}(m_j(x_2) - m_{j-1}(x_2)), \quad j = 1, \dots, N_1, \quad (7)$$

$$a_0(x_2) = f(0, x_2) - \sum_{j=1}^{N_1} (b_j(x_2) |x_1^{(j)}(x_2)|). \quad (8)$$

Representation (5) is specified by  $2N_1 + 2$  functions of one variable  $x_2$ :  $a_0(x_2)$ ,  $a_1(x_2)$ ,  $b_j(x_2)$ ,  $x_1^{(j)}(x_2)$ ,  $j = 1, \dots, N_1$ , which can be described by the equation (1). The equation (5) does not represent a two-dimensional piecewise-linear function because, when expanded, it contains quadratic terms  $x_1 x_2$ . It represent a piecewise-linear function only for a fixed value of  $x_2$ .

Similarly any continuous function  $f(x_1, x_2, x_3)$  which is piecewise-linear over each cross section obtained by freezing any two variables can be represented by the canonical form

$$\begin{aligned} f(x_1, x_2, x_3) &= a_0(x_2, x_3) + a_1(x_2, x_3) x_1 \\ &+ \sum_{j=1}^{N_1} (b_j(x_2, x_3) |x_1 - x_1^{(j)}(x_2, x_3)|), \end{aligned} \quad (9)$$

where  $a_0(x_2, x_3)$ ,  $a_1(x_2, x_3)$ ,  $b_j(x_2, x_3)$ ,  $x_1^{(j)}(x_2, x_3)$ ,  $j = 1, \dots, N_1$  are functions of two variables and can be represented by the equation (5). The section-wise piecewise-linear canonical representation for  $n > 3$  can be found in [11].

### 3. Building the fault dictionary

The section-wise piecewise-linear functions (SPLF) will be used to build the fault dictionary. We assume the ranges of changes of circuit parameters (e.g. resistances, forward  $\beta$  for transistors) and we trace parametric characteristics expressing voltages at the test nodes in terms of the parameters. In case  $n = 2$  SPICE simulator [12, 13] can be used to obtain the families of curves. We choose  $N_1$  and  $N_2$  depending on the shape of the obtained curves. The numerical experiments showed that it is more profitable to create functions SPLF not for the values of voltages and parameters but for their proportional changes in relation to the nominal values.

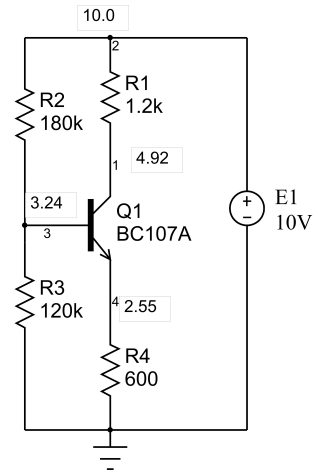

Fig. 1. Transistor circuit for an example

Let us consider the circuit shown in Fig. 1. The nominal values of the circuit elements and the node voltages are indicated in the figure. We wish to determine the section-wise piecewise-linear functions at node 1 and 3 in terms of the parameters  $R_3$  and  $R_4$ . We assume that the resistances can change within the range  $\pm 30\%$  of their nominal values, i.e.  $R_3 \in [84, 156]$  k $\Omega$ ,  $R_4 \in [420, 780]$   $\Omega$ . The families of parametric characteristics  $V_1(R_3)$  and  $V_3(R_3)$  for  $R_4$  assuming the discrete values belonging to the considered interval, with the step equals 72  $\Omega$ , are shown in Fig. 2. We assume  $N_2 = 5$  ( $R_4^{(1)} = 420$   $\Omega$ ,  $R_4^{(2)} = 450$   $\Omega$ ,  $R_4^{(3)} = 600$   $\Omega$ ,  $R_4^{(4)} = 670$   $\Omega$ ,  $R_4^{(5)} = 780$   $\Omega$ ), and  $N_1 = 3$  ( $R_3^{(1)} = 100$  k $\Omega$ ,  $R_3^{(2)} = 120$  k $\Omega$ ,  $R_3^{(3)} = 140$  k $\Omega$ ). Next we convert the values of the voltages and the parameters into relative changes ( $\tilde{V}_1$ ,  $\tilde{V}_3$ ,  $\tilde{R}_3$ ,  $\tilde{R}_4$  respectively) and execute the description of the families of characteristics using the SPLF representation (5), e.g. the SPLF representation of  $\tilde{V}_1(\tilde{R}_3, \tilde{R}_4)$  has the form

$$\begin{aligned} \tilde{V}_1(\tilde{R}_3, \tilde{R}_4) &= \\ &= (a_0(\tilde{R}_4))_{\tilde{V}_1} + (a_1(\tilde{R}_4))_{\tilde{V}_1} \tilde{R}_3 + (b_1(\tilde{R}_4))_{\tilde{V}_1} | \tilde{R}_3 - 16.67 | \\ &+ (b_2(\tilde{R}_4))_{\tilde{V}_1} | \tilde{R}_3 | + (b_3(\tilde{R}_4))_{\tilde{V}_1} | \tilde{R}_3 + 16.67 |. \end{aligned} \quad (10)$$

The functions  $(a_0(\tilde{R}_4))_{\tilde{V}_1}$ ,  $(a_1(\tilde{R}_4))_{\tilde{V}_1}$ ,  $(b_1(\tilde{R}_4))_{\tilde{V}_1}$ ,  $(b_2(\tilde{R}_4))_{\tilde{V}_1}$ ,  $(b_3(\tilde{R}_4))_{\tilde{V}_1}$  are represented by the equation (1). Similarly the SPLF for  $\tilde{V}_3(\tilde{R}_3, \tilde{R}_4)$  is created.

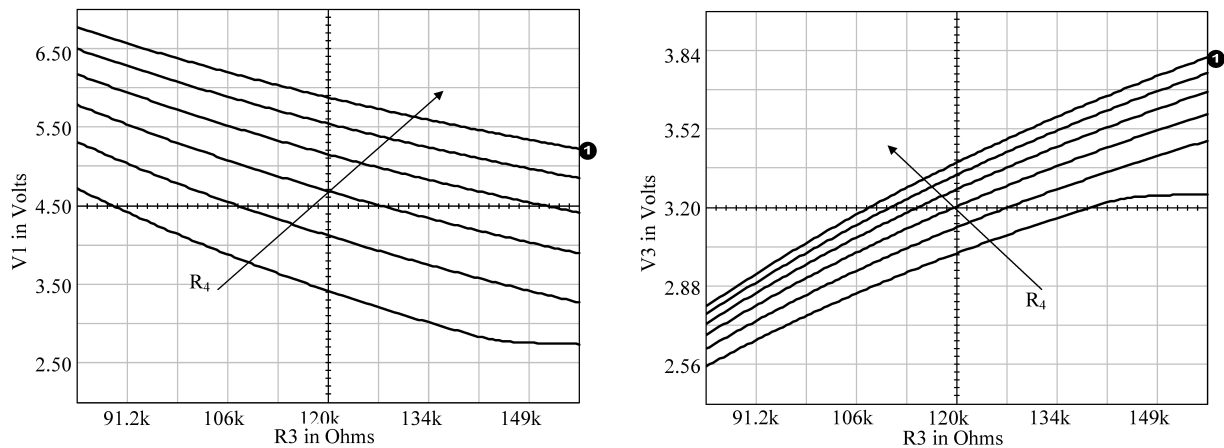

Fig. 2. Families of parametric characteristics

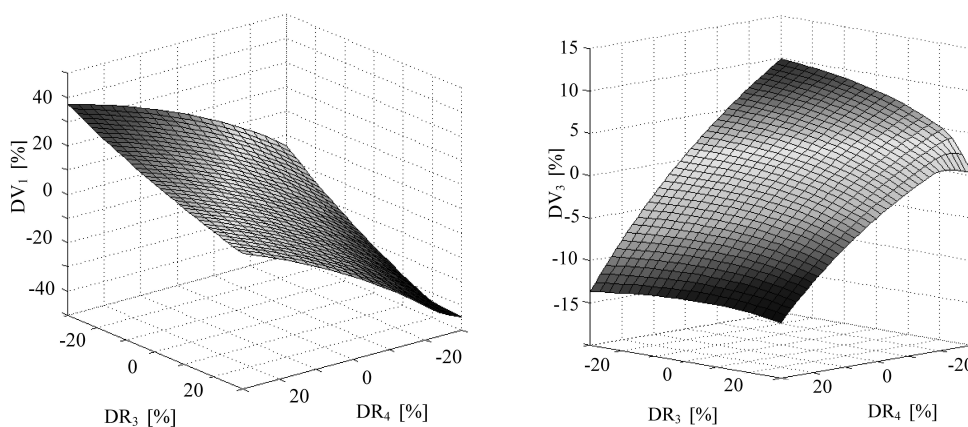

Fig. 3. The graphs of SPLF

As a result, the closed form analytical formulae for representing 2-dimensional surfaces are created, which are then stored as the signatures in the fault dictionary. To complete the signature the lower and upper bounds of voltages  $V_1$  and  $V_3$  ( $\underline{V}_1, \overline{V}_1, \underline{V}_3, \overline{V}_3$ , respectively) and the lower and upper bounds of resistances  $R_3$  and  $R_4$  ( $\underline{R}_3 = R_3^{(0)} = 84 \text{ k}\Omega$ ,  $\overline{R}_3 = R_3^{(4)} = 156 \text{ k}\Omega$ ,  $\underline{R}_4 = R_4^{(1)} = 420 \text{ }\Omega$ ,  $\overline{R}_4 = R_4^{(5)} = 780 \text{ }\Omega$ ) are stored. The graphs of the obtained SPLF are shown in Fig. 3, where  $DV_1 = \tilde{V}_1$ ,  $DV_3 = \tilde{V}_3$ ,  $DR_3 = \tilde{R}_3$  and  $DR_4 = \tilde{R}_4$ .

#### 4. Locating of the faulty elements

The process of the location of faulty elements and evaluating the values of parameters consists of analyzing all the signatures in the fault dictionary. After measurements in a tested circuit we search for these signatures for which the measured voltages are situated within the bounds connected with the given signature. Usually at this stage some sets of potentially faulty elements are eliminated. Afterwards the sets of nonlinear equations are solved using e.g. the Newton-Raphson algorithm or implemented in MATLAB the least squares method (fsolve.m). As the result we receive the sets of parameter values. From these sets we eliminate the ones for which the re-

ceived values of parameters lie outside the ranges stored in the fault dictionary. Finally we receive one or several solutions. Some of them can be eliminated by performing additional verifying research, e.g. executing the additional measurement in the circuit under test (e.g. the current received from the DC bias source) and carrying out SPICE simulations using the parameters from the obtained sets. Let us consider the example from the previous section. We assume the double fault case:  $R_3 = 91 \text{ k}\Omega$  and  $R_4 = 710 \text{ }\Omega$ . The measured voltages at the test nodes with the precision 0.1 mV, are:  $V_1 = 6.2812 \text{ V}$  and  $V_3 = 2.8896 \text{ V}$ . Using functions SPLF and the function fsolve of MATLAB we obtain the following values of these parameters:  $R_3 = 91.3 \text{ k}\Omega$  and  $R_4 = 713 \text{ }\Omega$ . The identical result can be obtained after 4 iterations of the Newton-Raphson method. The received values are very close to the assumed ones, that confirms the usefulness of the section-wise piecewise-linear representation in the fault diagnosis.

#### 5. Numerical examples

The proposed method was implemented in MATLAB and Delphi on PC Pentium Core2Duo 6400. The process of building of the fault dictionary was fully automated on the basis

of a netlist of the circuit. Numerous tests on several practical electronic circuits were performed. Two examples are presented in this section.

**5.1. Example 1.** Let us consider the video amplifier [9] having DC model shown in Fig. 4. We apply the parameters of the transistors from libraries of the IsSPICE [13]. The nominal values of the parameters and the nodal voltages of non-faulty circuit are indicated in the figure. We build the double-fault dictionary taking into account all the combinations of pairs of resistors:  $R_1, R_2, R_5, R_6, R_7, R_9, R_{10}$ . We assume that the resistances  $R_1, R_2$  can change in the range of  $\pm 30\%$ , and the remaining ones in the range of  $\pm 50\%$ . Let nodes 8 and 11 be accessible for measurements. We execute suitable simulations and describe two-dimensional surfaces by the the section-wise piecewise-linear functions. We choose  $N_1$  from the range  $1 \div 3$  and  $N_2$  from the range  $3 \div 5$ , depending on shapes of surfaces. As a result, we receive the fault dictionary containing 21 signatures. We assume that the measurement precision is 0.1 mV. The efficiency of proposed approach was verified on 40 sets of faults, including single and double faults. The time of calculations for every of the examined cases was below 100 ms. Five of the considered cases are described underneath.

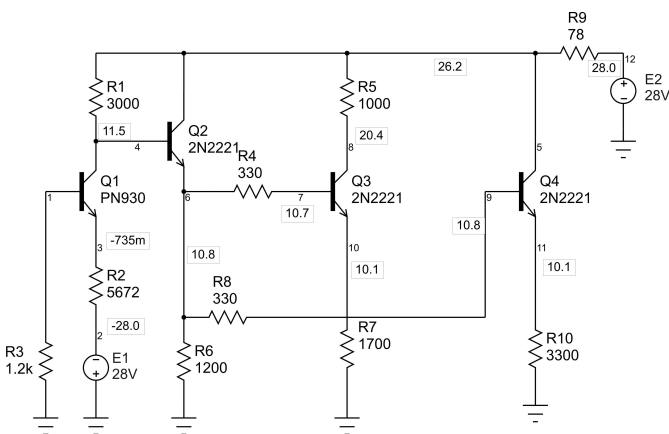

Fig. 4. DC model of video amplifier after Ref. 9

**Case 1.** Two elements  $R_1 = 2.2 \text{ k}\Omega$  and  $R_7 = 1 \text{ k}\Omega$  are faulty. The measured voltages at the test nodes are:  $V_8 = 12.9834 \text{ V}$ ,  $V_{11} = 13.0851 \text{ V}$ . The method developed in the paper gives the unique set  $\{R_1 = 2184 \Omega, R_7 = 940 \Omega\}$  of the faulty elements.

**Case 2.** Two elements  $R_5 = 1.4 \text{ k}\Omega$  and  $R_7 = 900 \Omega$  are faulty. The measured voltages at the test nodes are:  $V_8 = 11.0753 \text{ V}$ ,  $V_{11} = 9.7561 \text{ V}$ . The proposed method gives the unique set  $\{R_5 = 1437 \Omega, R_7 = 918 \Omega\}$  of the faulty elements.

**Case 3.** One element  $R_2 = 4.3 \text{ k}\Omega$  is faulty. The measured voltages at the test nodes are:  $V_8 = 23.0992 \text{ V}$ ,  $V_{11} = 6.1340 \text{ V}$ . The method developed in the paper gives 6 sets of potentially faulty elements:  $\{R_1 = 2998 \Omega, R_2 = 4335 \Omega\}$ ,  $\{R_2 = 4338 \Omega, R_5 = 1000 \Omega\}$ ,  $\{R_2 = 4338 \Omega, R_6 = 1199 \Omega\}$ ,  $\{R_2 = 4338 \Omega, R_7 = 1700 \Omega\}$ ,  $\{R_2 =$

$4338 \Omega, R_9 = 78 \Omega\}$ ,  $\{R_2 = 4338 \Omega, R_{10} = 3296 \Omega\}$ . Because all parameters in the pairs besides  $R_2$  are close to nominal, we conclude that the only faulty element is  $R_2 = 4337 \Omega$ .

**Case 4.** One element  $R_1 = 2.4 \text{ k}\Omega$  is faulty. The measured voltages at the test nodes are:  $V_8 = 18.6125 \text{ V}$ ,  $V_{11} = 12.6012 \text{ V}$ . The proposed method gives 11 sets of faulty elements, six of them indicate that the faulty element is  $R_1 = 2401 \Omega$ , and the remaining ones are:  $\{R_2 = 7130 \Omega, R_5 = 1010 \Omega\}$ ,  $\{R_2 = 7202 \Omega, R_6 = 1141 \Omega\}$ ,  $\{R_2 = 7133 \Omega, R_7 = 1689 \Omega\}$ ,  $\{R_2 = 7175 \Omega, R_9 = 81 \Omega\}$ ,  $\{R_2 = 7178 \Omega, R_{10} = 2898 \Omega\}$ . To eliminate some pairs we measure the current of the DC bias source  $E_2$ . Then we calculate this current performing SPICE simulations assuming the values of the elements from the above sets. For the single fault  $R_1 = 2401 \Omega$  we receive a value corresponding to the measured one. In the case of the remaining pairs of the elements some considerable differences appeared and we eliminate these pairs. As a result we obtain the correct identification of the faulty element.

**Case 5.** Two elements  $R_6 = 780 \Omega$  and  $R_9 = 40 \Omega$  are faulty. The measured voltages at the test nodes are:  $V_8 = 20.8047 \text{ V}$ ,  $V_{11} = 10.4877 \text{ V}$ . The proposed method gives 9 sets of the faulty elements. We perform the verification procedure similarly as in Case 4 obtaining the correct set of the faulty elements  $\{R_6 = 805 \Omega, R_9 = 40 \Omega\}$ . The percentage change of the current of source  $E_2$  for this set is about 1%, while for the remaining 8 sets these changes vary within the range of 17%–20%.

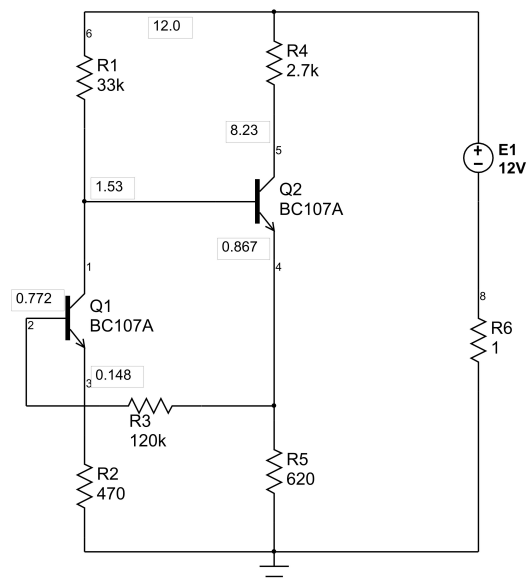

Fig. 5. DC model of voltage preamplifier

**5.2. Example 2.** Let us consider the voltage preamplifier having DC model shown in Fig. 5. We apply the parameters of transistors from libraries of the IsSPICE [13]. The nominal values of the parameters and the nodal voltages of a non-faulty circuit are indicated in the figure. We build a triple-fault dictionary taking into account all the combinations of

*Multiple soft fault diagnosis of nonlinear circuits using the fault dictionary approach*

resistors:  $R_1, R_2, R_3, R_4, R_5$ . We assume that the resistances can change within a range of  $\pm 30\%$  and we select nodes 1, 3 and 5 as the measuring ones. We execute suitable simulations and describe the surfaces by the section-wise piecewise-linear functions. As a result we receive the fault dictionary containing 10 signatures. We assume that the measurement precision is 0.01 mV and verify the efficiency of proposed approach on 25 sets of faults, including single, double and triple faults. The time of calculations for every of the examined cases was below 500 ms. Seven of the considered cases are described below.

**Case 1.** One element  $R_1 = 24 \text{ k}\Omega$  is faulty. The measured voltages at the test nodes are:  $V_1 = 1.62857 \text{ V}$ ,  $V_3 = 0.20175 \text{ V}$  and  $V_5 = 7.81296 \text{ V}$ . The method developed in the paper gives 6 sets of the faulty elements, which indicates that the faulty element is  $R_1 = 24250 \Omega$ .

**Case 2.** One element  $R_5 = 470 \Omega$  is faulty. The measured voltages at the test nodes are:  $V_1 = 1.53556 \text{ V}$ ,  $V_3 = 0.14722 \text{ V}$  and  $V_5 = 7.03699 \text{ V}$ . The proposed method gives 6 sets of the faulty elements, which indicates that the faulty element is  $R_5 = 474 \Omega$ .

**Case 3.** Two elements  $R_2 = 350 \Omega$  and  $R_3 = 150 \text{ k}\Omega$  are faulty. The measured voltages at the test nodes are:  $V_1 = 1.51531 \text{ V}$ ,  $V_3 = 0.11026 \text{ V}$  and  $V_5 = 8.29234 \text{ V}$ . The method gives 3 sets of faulty elements:  $\{R_1 = 33261 \Omega, R_2 = 352 \Omega, R_3 = 151313 \Omega\}$ ,  $\{R_2 = 350 \Omega, R_3 = 150009 \Omega, R_4 = 2700 \Omega\}$ ,  $\{R_2 = 350 \Omega, R_3 = 150009 \Omega, R_5 = 620 \Omega\}$ . Because all parameters in the sets besides  $R_2$  and  $R_3$  are close to nominal, we conclude that the faulty elements are  $R_2 = 350 \Omega$  and  $R_3 = 150145 \Omega$ .

**Case 4.** Two elements  $R_1 = 24000 \Omega$  and  $R_5 = 780 \Omega$  are faulty. The measured voltages at the test nodes are:  $V_1 = 1.62350 \text{ V}$ ,  $V_3 = 0.20223 \text{ V}$  and  $V_5 = 8.66823 \text{ V}$ . The method gives 5 sets of faulty elements. The analysis of these sets (similarly as in Case 3) leads to three solutions:  $\{R_1 = 24139 \Omega, R_5 = 781 \Omega\}$ ,  $\{R_1 = 25072 \Omega, R_2 = 488 \Omega, R_4 = 2159 \Omega\}$ ,  $\{R_1 = 24097 \Omega, R_3 = 114695 \Omega, R_4 = 2159 \Omega\}$ . We perform the verification procedure similarly as in Example 1 obtaining the correct set of faulty elements  $\{R_1 = 24139 \Omega, R_5 = 781 \Omega\}$ .

**Case 5.** Three elements  $R_1 = 27000 \Omega$ ,  $R_3 = 150000 \Omega$  and  $R_5 = 470 \Omega$  are faulty. The measured voltages at the test nodes are:  $V_1 = 1.62291 \text{ V}$ ,  $V_3 = 0.17867 \text{ V}$  and  $V_5 = 6.54962 \text{ V}$ . The method gives one set of faulty elements  $\{R_1 = 27147 \Omega, R_3 = 150217 \Omega, R_5 = 474 \Omega\}$ .

**Case 6.** Three elements  $R_2 = 380 \Omega$ ,  $R_4 = 3300 \Omega$  and  $R_5 = 800 \Omega$  are faulty. The measured voltages at the test nodes are:  $V_1 = 1.49530 \text{ V}$ ,  $V_3 = 0.12025 \text{ V}$  and  $V_5 = 8.54127 \text{ V}$ . The proposed method gives 7 sets of faulty elements. Performing the verification procedure similarly as in Example 1 we obtain the correct set of faulty elements  $\{R_2 = 380 \Omega, R_4 = 3298 \Omega, R_5 = 800 \Omega\}$ .

**Case 7.** Three elements  $R_2 = 600 \Omega$ ,  $R_3 = 150000 \Omega$  and  $R_4 = 2000 \Omega$  are faulty. The measured voltages at the test nodes are:  $V_1 = 1.59344 \text{ V}$ ,  $V_3 = 0.18740 \text{ V}$  and  $V_5 = 9.00875 \text{ V}$ . The proposed method gives 3 sets of faulty elements:  $\{R_1 = 27630 \Omega, R_2 = 500 \Omega, R_4 = 2000 \Omega\}$ ,

$\{R_1 = 26141 \Omega, R_3 = 111288 \Omega, R_4 = 2000 \Omega\}$ ,  $\{R_2 = 600 \Omega, R_3 = 150015 \Omega, R_4 = 2000 \Omega\}$ . The verification procedure does not eliminate any set. In this case we obtain three solution, the one correct and two virtual ones.

## 6. Conclusions

The SBT approach, developed in this paper, enables us to perform efficiently the diagnosis of DC transistor circuits. A key point of building of the fault dictionary is a description of the  $n$ -dimensional surfaces using the section-wise piecewise-linear functions. Numeric tests passed on several practical electronic circuits confirmed the efficiency of the proposed method. The large influence on the number of received solutions has the value of deviations of the faulty elements and the existence of ambiguity sets. In many cases it is necessary to perform additional verifying procedures to eliminate some sets. The influence of the chosen test nodes is also essential. The DC sensitivity analysis can be helpful in this matter or some specialized techniques of their optimal selection can be used.

## REFERENCES

- [1] W. Hochwald and J. D. Bastian, "A dc approach for analog fault dictionary determination", *IEEE Trans. Cir. Syst.* 26, 523–529 (1979).
- [2] T. Ozawa, *Analog Methods for Computer – Aided Circuit Analysis and Diagnosis*, M. Dekker, New York, 1988.
- [3] M. Worsman and M.W.T. Wong, "Non-linear analog circuit fault diagnosis with large change sensitivity", *Int. J. Cir. Theor. Appl.* 28, 281–303 (2000).
- [4] M. Tadeusiewicz, S. Hałgas, and M. Korzybski, "An algorithm for soft-fault diagnosis of linear and nonlinear circuits", *IEEE Tran. Cir. Syst.* 49, 1648–1653 (2002).
- [5] J. Rutkowski, *Dictionary Approach to Fault Diagnosis in Analogue Circuits*, WKŁ, Warszawa, 2003, (in Polish).
- [6] J.A. Starzyk, D. Liu, Z. Liu, D.E. Nelson, and J. Rutkowski, "Entropy-based optimum test points selection for analog fault dictionary techniques", *IEEE Trans. Inst. Measur.* 53, 754–761 (2004).
- [7] M. Tadeusiewicz, S. Hałga, and P. Sidyk, "Building and exploiting fault dictionary for transistor circuits diagnosis", *Proc. XIII Int. Symp. Theor. Electr. Eng.*, 388–391 (2005).
- [8] M. Tadeusiewicz and S. Hałgas, "An algorithm for multiple fault diagnosis in analogue circuits", *Int. J. Cir. Theor. Appl.* 34, 607–615 (2006).
- [9] N. Navid and A.N. Willson, "A theory and an algorithm for analog circuit fault diagnosis", *IEEE Trans. Cir. Syst.* 26, 440–457 (1979).
- [10] S. Hałgas, "Multiple soft fault diagnosis of nonlinear circuits using the fault dictionary approach", *Proc. National Conf. Electronics* 1, 119–124 (2007), (in Polish).
- [11] L.O. Chua and S.M. Kang, "Section-wise piecewise-linear functions: Canonical representation, properties, and applications", *Proc. IEEE* 65, 915–929 (1977).
- [12] T.L. Quarles, A.R. Newton, D.O. Pederson, and A. Sangiovanni-Vincentelli, *SPICE-3 Version 3F5 User's Manual*, Berkeley, California, 1994.
- [13] *ICAP/4 – IsSpice 4 user's guide*, Intusoft, 1998.