

Research Paper

Magnetoacoustic Heating of Plasma Caused by Periodic Magnetosound Perturbations with Discontinuities in a Quasi-Isentropic Magnetic Gas

Anna PERELOMOVA

Gdansk University of Technology

Faculty of Applied Physics and Mathematics

Gabriela Narutowicza 11/12, 80-233 Gdansk, Poland; e-mail: anna.perelomova@pg.edu.pl

(received November 9, 2019; accepted January 3, 2020)

The magnetoacoustic heating of plasma by harmonic or periodic saw-tooth perturbations at a transducer is theoretically studied. The planar fast and slow magnetosound waves are considered. The wave vector may form an arbitrary angle θ with the equilibrium straight magnetic field. In view of variable θ and plasma- β , the description of magnetosound perturbations and appropriate magnetosound heating is fairly difficult. The scenario of heating depends not only on plasma- β and θ , but also on a balance between nonlinear attenuation at the shock front and inflow of energy into a system. Under some conditions, the average over the magnetosound period force of heating may tend to a positive or negative limit, tend to zero, or may remain constant when the distance from a transducer tends to infinity. Dynamics of temperature specifying heating differs in thermally stable and unstable cases and occurs unusually in the isentropically unstable flows.

Keywords: non-linear magnetoacoustics; shock waves; adiabatical instability; acoustic activity; acoustic heating.

1. Introduction

Nonlinear wave theory studies not only distortions of intense waves in the course of their propagation, but also the nonlinear effects associated with them. Among them, excitation of non-wave modes are of especial importance. The entropy mode is responsible for isobaric variations of the medium's background temperature, and the vortex mode associates with the bulk vortex velocity with zero perturbations in temperature and pressure. If these modes enhance in the field of intense sound, they are not longer stationary but slowly varying in time. They are called acoustic heating and streaming (RUDENKO, SOLUYAN, 1977; HAMILTON, BLACKSTOCK, 1998). Similarly, we may call nonlinear excitation of the non-wave modes by intense magnetosound perturbations magnetosound heating and streaming. Close attention to the wave processes and associated with them nonlinear phenomena in a plasma is constantly growing. Remote observations of wave processes and appropriate effects are often the only way to conclude about properties of a plasma and physical processes in it (KELLY, NAKARIAKOV, 2004; BALLAI, 2006).

Variety of magnetosound modes provides diversity of nonlinear phenomena. In particular, excess temperature in the secondary entropy mode depends on plasma- β , degree of non-adiabaticity and geometry of a flow. In view of difficulty in general analytical description, we focus on the planar flow of an ideal magnetic gas affected by the straight equilibrium magnetic field which forms constant angle θ with the wave vector. The planar or quasi-planar geometry fits well with perturbations excited by planar transducer and may reproduce the conditions of remote plasma's flow. Deviations from flow's adiabaticity play the key role in wave dynamics and appropriate nonlinear phenomena. Taken alone, without attenuation due to friction and thermal conduction, non-adiabaticity is the only reason for interactions of modes, along with nonlinearity. Inflow of energy into the system may enhance wave perturbations in the course of propagation (SINGH *et al.*, 2012; OJHA, SINGH, 1991). This results in anomalous excitation of the secondary modes (MOLEVICH, 2001a; PERELOMOVA, 2010; 2012). On the other hand, enlargement of wave perturbations balanced by the nonlinear attenuation at the shock front may lead to formation of autowaves or stationary wave forms

(MAKARYAN, 2007; GEFFEN, 1963; SHARMA *et al.*, 1981). These kinds of wave forms are of especial importance due to the following reasons: any perturbation at a transducer evolves into a set of autowaves; they are the simplest mathematical case as well as corresponding nonlinear phenomena. Dynamics of the wave forms depends not only on the degree of deviation from adiabaticity due to inflow of energy, but also on a balance of this degree and nonlinear distortions which in turn depends on the magnitude of wave perturbations, parameter of nonlinearity, and wave speed (these latter values are functions of plasma- β and θ). The magnetoacoustic heating may also develop in other scenarios which will be discussed in details later.

The text is organised as follows. Section 2 introduces a generic heating-cooling function, reminds the initial system of PDEs describing motion of an ideal magnetic gas, modes in a linear flow, and conditions of isentropic and thermal instability. Projectors in a linear flow are mentioned as a method to derive linear and weakly nonlinear dynamic equations. This section refers to the previous results. In Sec. 3, periodic magnetoacoustic perturbations are analytically studied. The attention is paid to conditions of discontinuity formation, waves with shock fronts and autowaves in two cases: sinusoidal velocity at a transducer and the sawtooth velocity at a transducer. Dynamics of the intense sawtooth shaped perturbations were studied by the author in (PERELOMOVA, 2019). Magnetosound heating caused by these kinds of exciters is analytically studied in Sec. 4. Section 5 presents the conclusions.

2. Modes in the linear MHD flow

We make use of a set of ideal MHD (magnetohydrodynamic) equations describing a perfectly electrically conducting gas. It includes the continuity equation, momentum equation, energy balance equation, and electrodynamic equations in the differential form (FREIDBERG, 1987; KRALL, TRIVELPIECE, 1973):

$$\begin{aligned} \frac{\partial \rho}{\partial t} + \nabla \cdot (\rho \mathbf{v}) &= 0, \\ \rho \frac{D\mathbf{v}}{Dt} &= -\nabla p + \frac{1}{\mu_0} (\nabla \times \mathbf{B}) \times \mathbf{B}, \\ \frac{Dp}{Dt} - \gamma \frac{p}{\rho} \frac{D\rho}{Dt} &= (\gamma - 1)L(p, \rho), \\ \frac{\partial \mathbf{B}}{\partial t} &= \nabla \times (\mathbf{v} \times \mathbf{B}), \\ \nabla \cdot \mathbf{B} &= 0, \end{aligned} \quad (1)$$

where p , ρ , \mathbf{v} are thermodynamic pressure and density of a plasma, and its velocity. Magnetic flux density is denoted by \mathbf{B} , and μ_0 is the permeability of the free space. The third equation in the set (1) refers to an ideal gas with the ratio of specific heats under con-

stant pressure and constant density γ , $\gamma = C_P/C_V$. The fourth equation is the ideal induction equation, and the fifth one is the Maxwell's equation reflecting solenoidal character of \mathbf{B} . The generic heating-cooling function $L(p, \rho)$ is responsible for non-isentropicity of a flow (NAKARIAKOV *et al.*, 2000). It reflects inflow of energy into a system and losses due to radiation.

Following NAKARIAKOV *et al.* (2000), we assume that the wave vector of a planar flow forms constant angle θ ($0 \leq \theta \leq \pi$) with the constant straight equilibrium magnetic field \mathbf{B}_0 . Direction of the wave vector is pointed by axis z . The y -component of \mathbf{B}_0 equals zero, so as

$$B_{0,x} = B_0 \sin(\theta), \quad B_{0,z} = B_0 \cos(\theta), \quad B_{0,y} = 0.$$

The system (1) displays the nonlinearity of MHD flows. For further analysis, its leading order form considered, valid with accuracy up to quadratic nonlinear terms (NAKARIAKOV *et al.*, 2000; PERELOMOVA, 2016a; 2018a). The linear flow (that is, a flow with infinitely small perturbations of thermodynamic variables) is described by the linearised version of the system (1). We consider first the linear flows. All thermodynamic quantities are expanded in the vicinity of the equilibrium thermodynamic state as $f(z, t) = f_0 + f'(z, t)$. A plasma is motionless in equilibrium: $\mathbf{v}_0 = \mathbf{0}$. The leading order seven equations include first partial derivatives of variables ρ' , v_x , v_y , v_z , p' , B_x , B_y with respect to time. The energy equation contains terms proportional to L_p , L_ρ in its linear part and terms proportional to L_{pp} , $L_{p\rho}$, $L_{\rho\rho}$ in its nonlinear part, where

$$\begin{aligned} L_p &= \frac{\partial L}{\partial p}, & L_\rho &= \frac{\partial L}{\partial \rho}, & L_{pp} &= \frac{\partial^2 L}{\partial p^2}, \\ L_{\rho\rho} &= \frac{\partial^2 L}{\partial \rho^2}, & L_{p\rho} &= \frac{\partial^2 L}{\partial p \partial \rho} \end{aligned}$$

are partial derivatives of the heating-cooling function $L(p, \rho)$ with respect to its variables evaluated at equilibrium state (p_0, ρ_0) . The dispersion relations follow from the linearised Eqs (1), if one looks for solutions of the linearised equations in the form of a sum of planar waves proportional to $\exp(i\omega(k_z)t - ikz)$, where k designates the wave number, so as

$$\begin{aligned} f'(z, t) &= \int_{-\infty}^{\infty} \tilde{f}(k) \exp(i\omega(k)t - ikz) dk, \\ \omega_{1,2} &= \pm C_{A,z} k, \quad \omega_j = C_j k - iC_j D_j, \\ \omega_7 &= \frac{i(\gamma - 1)L_\rho}{c_0^2}, \end{aligned} \quad (2)$$

where $j = 3, \dots, 6$, C_j is the magnetosound speed satisfying the equation

$$C_j^4 - C_j^2(c_0^2 + C_A^2) + c_0^2 C_{A,z}^2 = 0, \quad (3)$$

C_A and c_0

$$C_A = \frac{B_0}{\sqrt{\mu_0 \rho_0}}, \quad c_0 = \sqrt{\frac{\gamma p_0}{\rho_0}}$$

designate the Alfvén speed and the acoustic speed in non magnetised gas in equilibrium, $C_{A,z} = C_A \cos(\theta)$, and

$$D_j = \frac{C_j(C_j^2 - C_A^2)(\gamma - 1)}{2c_0^2(C_j^4 - c_0^2 C_{A,z}^2)}(c_0^2 L_p + L_\rho).$$

The first two roots ω_1, ω_2 specify the Alfvén waves. The next four roots refer to slow and fast magnetosound waves, which rely on compressibility, and the last root ω_7 corresponds to the entropy mode. The vortex mode does not exist in the planar geometry of a flow. For any non zero magnetosound speed C_j , the denominator in the expression for D_j differs from zero except the case $|C_j| = c_0 = C_A$, since zero $C_j^2 - c_0^2 C_{A,z}^2$ leads to equalities $C_{A,z} = \frac{c_0^2 + C_A^2}{2c_0}$ and $C_{A,x}^2 = -\frac{(c_0^2 - C_A^2)^2}{4c_0^2}$. The degenerative case $|C_j| = C_A = c_0$ is beyond interest. $|C_j| = C_A$ is not acoustic case, and $|C_j| = c_0$ corresponds to the flow in non-magnetized gas. The dispersion relations Eqs (2) and Eq. (3) have been established by NAKARIAKOV *et al.* (2000) and CHIN *et al.* (2010). The magnetosound perturbations may enhance if a linear flow is adiabatically unstable (FIELD, 1965; PARKER, 1953), that is, if

$$c_0^2 L_p + L_\rho > 0. \quad (4)$$

The condition of thermal instability $L_\rho < 0$ ensures enlargement of perturbations specifying the entropy mode in a linear flow. The projecting rows readily follow from the dispersion relations and corresponding links of perturbations specifying any mode (PERELOMOVA, 2006; 2016b; 2018a). Operators projecting the total vector of disturbances into specific excess densities, satisfy the equalities

$$P_j \begin{pmatrix} \rho' & v_x & v_y & v_z & p' & B_x & B_y \end{pmatrix}^T = \rho_j, \quad j = 3, \dots, 7.$$

They have been established in the leading order by the author in (PERELOMOVA, 2018a). In particular, the projecting row onto an excess density specifying the entropy mode, takes the form

$$P_7 = \begin{pmatrix} 1 & a^* & 0 & b^* & -\frac{1}{c_0^2} & 0 & 0 \end{pmatrix}, \quad (5)$$

where

$$a^* = -\frac{(\gamma - 1)C_{A,x}\rho_0}{C_{A,z}c_0^4}(c_0^2 L_p + L_\rho) \int dz,$$

$$b^* = -\frac{(\gamma - 1)\rho_0}{c_0^4}(c_0^2 L_p + L_\rho) \int dz.$$

Projectors are useful in derivation of systems of coupling nonlinear dynamic equations which account for interactions of different modes in various kinds of nonlinear flows (LEBLE, PERELOMOVA, 2018).

3. Periodic magnetoacoustic waves with shock fronts

The evolution equation governing velocity in individual magnetosound wave has been derived by NAKARIAKOV *et al.* (2000):

$$\frac{\partial v_z}{\partial t} + C \frac{\partial v_z}{\partial z} - DCv_z + \varepsilon v_z \frac{\partial v_z}{\partial z} = 0, \quad (6)$$

where ε responses for nonlinear distortions,

$$\varepsilon = \left(\frac{(\gamma + 1)c_0^2(C^2 - C_{A,z}^2)}{2(C^4 - c_0^2 C_{A,z}^2)} + \frac{3C^4 C_{A,x}^2}{2(C^2 - C_{A,z}^2)(C^4 - c_0^2 C_{A,z}^2)} \right).$$

Zero denominator $C^2 - C_{A,z}^2$ in the right hand side equals zero if $C = 0$ or $|C| = C_A$ (this is out of interest since it is not an acoustic case). The ordering number of magnetosound mode will be omitted. The Eq. (6) does not consider nonlinear interaction between modes but individual evolution of velocity in one dominant magnetosound mode. Dominance suggests that magnitudes of perturbations specifying this mode are much bigger than that of other modes. Equation (6) refers to both slow and fast modes. Equation (6) is very similar to equations describing perturbations in open flows which may be acoustically active (OSIPOV, UVAROV, 1992; MOLEVICH, 2001b; ZAVERSHINSKY *et al.*, 2015; LEBLE, PERELOMOVA, 2018). For definiteness, we consider modes with $C > 0$, that is, slow or fast modes propagating in the positive direction of axis z . Equation (6) by means of new variables (for non zero D, C)

$$V = v_z \exp(-Dz), \quad Z = \frac{e^{Dz} - 1}{D}, \quad \tau = t - z/C$$

rearranges into the leading order equation:

$$\frac{\partial V}{\partial Z} - \frac{\varepsilon}{C^2} V \frac{\partial V}{\partial \tau} = 0. \quad (7)$$

Note that Z is always positive for non zero D . Equation (7) is well studied in the nonlinear wave theory (RUDENKO, SOLUYAN, 1977; SHARMA *et al.*, 1987; HAMILTON, BLACKSTOCK, 1998). It may be solved by the method of characteristics. Discontinuity in the wave form always forms in acoustically active media (that is, in the case $D > 0$) (OSIPOV, UVAROV, 1992).

3.1. Harmonic at a transducer magnetosound velocity

The leading-order solution to Eq. (6) which is sinusoidal at $z = 0$ with period T_0 , reads

$$v_z = v_0 \exp(Dz)$$

$$\sum_{n=1}^{\infty} \frac{2J_n(n\pi K^{-1}(\exp(Dz) - 1)) \sin(2\pi n\tau/T_0)}{n\pi K^{-1}(\exp(Dz) - 1)}, \quad (8)$$

where J_n designates the Bessel functions of the first kind, v_0 denotes an amplitude of velocity at a transducer,

$$v_z(z = 0, t) = v_0 \sin(2\pi t/T_0)$$

and

$$K = \frac{DC^2T_0}{2\varepsilon v_0}.$$

It is the Bessel-Fubini solution valid before formation of a discontinuity (RUDENKO, SOLUYAN, 1977; OSIPOV, UVAROV, 1992), that is, if

$$0 < z < z_{sh} = \ln(1 + K/\pi)D^{-1}.$$

A discontinuity always forms in acoustically active flows with $K > 0$ (that is, $D > 0$) and in the case

$-\pi < K \leq 0$ at the distance z_{sh} and does not form at all if $K \leq -\pi$. If $\theta = 0$ or $\theta = \pi$, the distance of shock formation changes abruptly at $\beta = \frac{2}{\gamma}$, where

$$\beta = \frac{2c_0^2}{\gamma C_A^2}$$

is the plasma- β . If $\theta = 0$ or $\theta = \pi$, there are two speeds of propagation along axis z , c_0 , and C_A . They are equal in the degenerate case $\beta = \frac{2}{\gamma}$. For fast magnetosound perturbations and $\beta < \frac{2}{\gamma}$, $|D|_{z_{sh}} = 0$, and in the case $\beta > \frac{2}{\gamma}$, $|D|_{z_{sh}} = \ln(2\pi) - \ln(2\pi - \frac{(\gamma-1)T_0(c_0^2L_p+L_\rho)}{(\gamma+1)v_0c_0})$. In the case of slow perturbations, $|D|_{z_{sh}}$ jumps at $\beta = \frac{2}{\gamma}$ from $\ln(2\pi) - \ln(2\pi - \frac{(\gamma-1)T_0(c_0^2L_p+L_\rho)}{(\gamma+1)v_0c_0})$ till 0. The di-

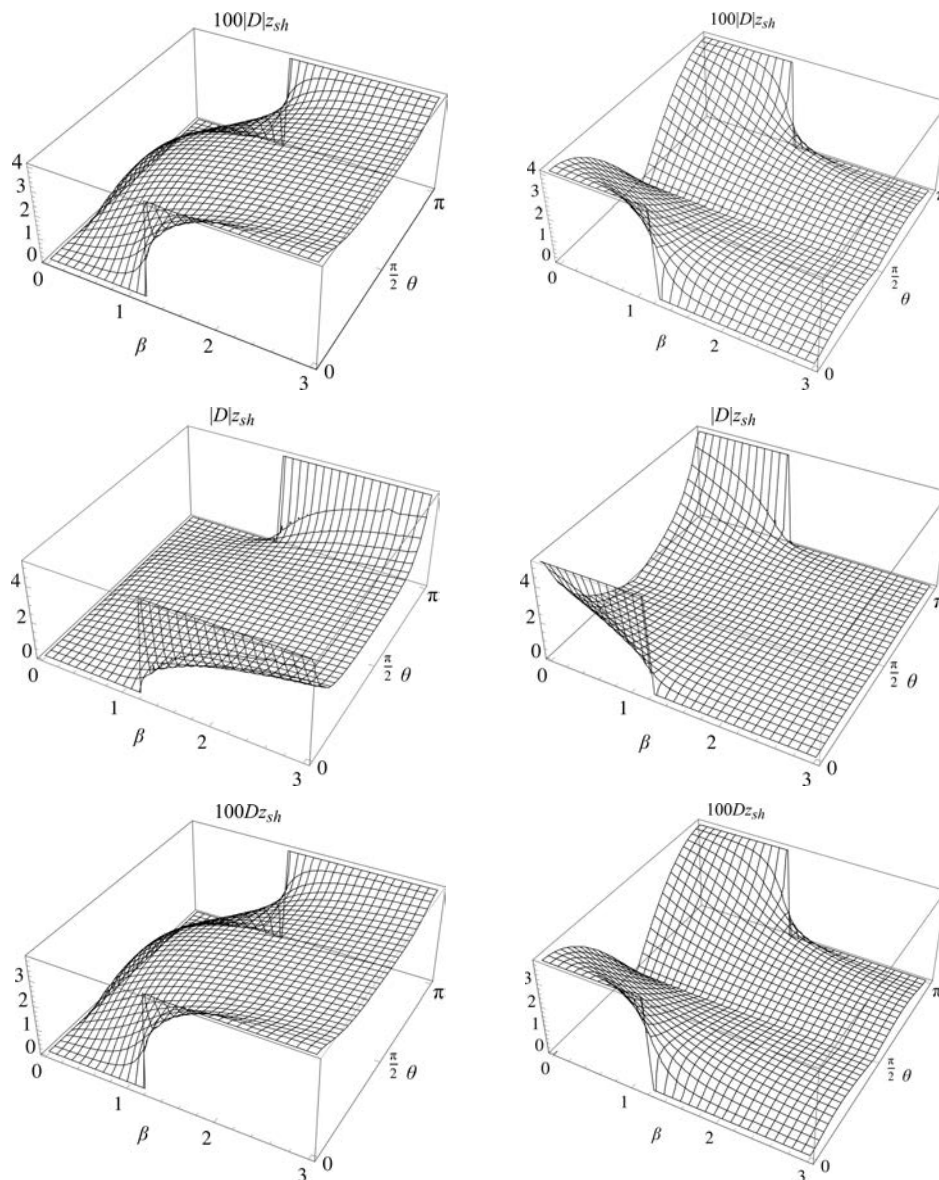

Fig. 1. Dimensionless distance of the discontinuity formation, $|D|_{z_{sh}}$ at $\frac{v_0c_0}{T_0(c_0^2L_p+L_\rho)} = -1$ (top row), $\frac{v_0c_0}{T_0(c_0^2L_p+L_\rho)} = -0.04$ (middle row), $\frac{v_0c_0}{T_0(c_0^2L_p+L_\rho)} = 1$ (bottom row). Fast magnetosound perturbations (left panels) and slow magnetosound perturbations (right panels).

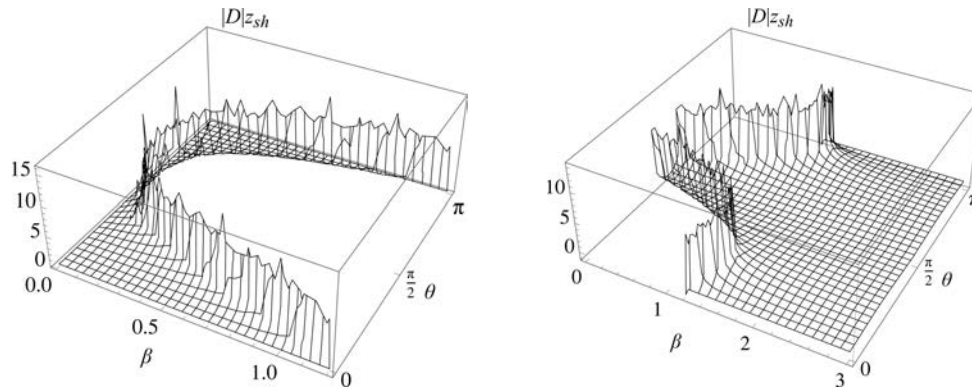

Fig. 2. Dimensionless distance of the discontinuity formation, $|D|z_{sh}$ at $\frac{v_0 c_0}{T_0(c_0^2 L_p + L_\rho)} = -0.01$. Fast magnetosound perturbations (left panel) and slow magnetosound perturbations (right panel).

dimensionless distance from a transducer $|D|z_{sh}$ at which the discontinuity forms for some values of $\frac{v_0 c_0}{T_0(c_0^2 L_p + L_\rho)}$, is shown in Fig. 1. All plots and calculations were made in *Mathematica*. The limiting value ensuring formation of discontinuity for all β, θ and both fast and slow perturbations, is $\frac{v_0 c_0}{T_0(c_0^2 L_p + L_\rho)} = -\frac{\gamma-1}{2\pi(\gamma+1)}$ (approximately -0.04 for $\gamma = 5/3$). For larger negative values, the domains in the plane β, θ appear where the discontinuity does not form. Figure 2 shows these domains for $\frac{v_0 c_0}{T_0(c_0^2 L_p + L_\rho)} = -0.01$. All plots refer to $\gamma = 5/3$.

The approximate solution to Eq. (6) which is sinusoidal at $z = 0$ at distances from a transducer $z > \pi z_{sh}/2$ (obviously, this is the case $K > -\pi$), developed discontinuity and negligible curvature in the sloping parts of wave form), is

$$v_z(z, \tau) = \frac{2v_0 e^{Dz}}{1 + \pi K^{-1}(e^{Dz} - 1)} \sum_{n=1}^{\infty} \frac{\sin(2\pi n\tau/T_0)}{n}. \quad (9)$$

There is a domain which is difficult for analytical description, between z_{sh} and $\pi z_{sh}/2$.

3.2. Periodic saw-tooth perturbations at a transducer

We will consider the saw-tooth profile of velocity at a transducer which is zero on average. One period of perturbations T_0 at a transducer situated at $z = 0$, is determined by the formula

$$\frac{V}{v_0} = \begin{cases} -1 - 2\frac{\tau}{T_0}, & -\frac{T_0}{2} \leq \tau \leq 0, \\ 1 - 2\frac{\tau}{T_0}, & 0 < \tau \leq \frac{T_0}{2}. \end{cases} \quad (10)$$

The method of characteristics results in a solution of Eq. (7) in the form of the series of saw-tooth impulses of the constant period T_0 with variable magnitude depending on the distance from a transducer (PERELOMOVA, 2019):

$$v_z(z, \tau) = \frac{v_0 e^{Dz}}{1 + K^{-1}(e^{Dz} - 1)} \begin{cases} -1 - 2\frac{\tau}{T_0}, & -\frac{T_0}{2} \leq \tau \leq 0, \\ 1 - 2\frac{\tau}{T_0}, & 0 < \tau \leq \frac{T_0}{2}. \end{cases} \quad (11)$$

By expanding in a series, it takes the equivalent form

$$v_z(z, \tau) = \frac{2v_0 e^{Dz}}{\pi(1 + K^{-1}(e^{Dz} - 1))} \sum_{n=1}^{\infty} \frac{\sin(2\pi n\tau/T_0)}{n}, \quad (12)$$

very similar to Eq. (9). The main conclusion is that once a shock is formed at a transducer, it exists at all distances from it and remains saw-tooth at any K . The scenario at large distances depends on the sign of D : amplitude of velocity tends to zero if $D < 0$ and tends to $\frac{DC^2 T_0}{2\varepsilon}$ in an acoustically active flow. It is remarkable that the limiting magnitude in an acoustically active flow does not depend on the initial magnitude of an impulse v_0 . This has been established by PERELOMOVA (2019) but is valid also for the harmonic at a transducer sound with developed discontinuity.

4. Magnetoacoustic heating caused by periodic at a transducer exciter

We will consider both harmonic (before and after formation of discontinuity) and saw-tooth at a transducer magnetosound perturbations as exciters of heating. In nonlinear acoustics, heating means usually variations of temperature and density in isobaric process associating with the entropy mode due to nonlinear losses in energy of the intense sound. In turn, slow entropy perturbations form a new background of waves propagation. There are many examples of acoustically active flows, where nonlinear interaction of wave and non wave modes (in particular, acoustic heating) occurs unusually (MOLEVICH, 2001a; PERELOMOVA,

2014; LEBLE, PERELOMOVA, 2018). The medium may cool down. The equation governing an excess density in the entropy mode has been obtained by the author in (PERELOMOVA, 2018a) by use of projecting. We reproduce one of its forms:

$$\begin{aligned} \frac{\partial \rho_\tau}{\partial t} + \frac{(\gamma + 1)L_\rho}{c_0^2} \rho_\tau = & \\ - \frac{\rho_0}{4C^2 c_0^2} \left(\frac{1}{C_{A,x}^2 (c_0^2 C_{A,z}^2 - C^4)} (\gamma - 1) (c_0^6 (c_0^2 L_p + L_\rho) \right. & \\ + C^2 c_0^2 (c_0^2 - C_{A,z}^2 (\gamma - 3) + C^4 (2c_0^2 L_p + (2C_A^2 - C_{A,z}^2) L_p & \\ + c_0^2 (C_{A,z}^2 (1 - 2\gamma) L_p + 2(\gamma C_A^2 L_p + L_\rho)))) v_z^2 & \\ + 2(\gamma - 1) (c_0^4 L_{pp} + 2c_0^2 L_{p\rho} + L_{\rho\rho}) \rho_0 v_z^2 & \\ \left. - \frac{c^*}{c_0^2 + C_A^2 - 2C^2} - \frac{d^*}{c_0^2 + C_A^2 - 2C^2} \right), & \quad (13) \end{aligned}$$

where

$$\begin{aligned} c^* = 2(3C^2 - 2c_0^2 - C_A^2) (\gamma - 1) \gamma (c_0^2 L_p + L_\rho) \frac{\partial v_z}{\partial z} & \\ \cdot \int v_z(z', t) dz' + 2(C^2 - C_A^2) (\gamma - 1) (c_0^2 L_p + L_\rho) v_z^2, & \\ d^* = 2(C^2 - C_A^2) (\gamma - 1) (c_0^2 L_p + L_\rho) & \\ \cdot \left(v_z^2 + \frac{\partial v_z}{\partial z} \int v_z(z', t) dz' \right). & \end{aligned}$$

Zero $C_{A,x}$ in the denominator corresponds to $C = 0$ or $|C| = C_A$. Both these cases are beyond interest. The acoustic force in the right hand side of equation is nonlinear and proportional to the first and second partial derivatives of L with respect to its variables p and ρ . Equation (13) is instantaneous and refers to any heating-cooling function. In this study, we do not consider impact of the second order derivatives of L with respect to its variables and set them to zero. Evaluations may be simplified by taking average of Eq. (13) in the case of quasi-periodic exciters. For any quasi-periodic velocity which is a product of two functions, one of them (f_1) being slowly varying over the wavelength (this is also the case of Eqs (8), (9), (12), where $|D| \ll k$ ensures the wave processes),

$$v_z = f_1(Dz) f_2(\tau),$$

which is zero on average,

$$\frac{1}{T_0} \int_\tau^{\tau+T_0} v_z d\tau = 0,$$

the leading order equality takes place

$$\begin{aligned} \overline{v_z^2} &= \frac{1}{T_0} \left(v_z \int v_z d\tau \right) \Big|_\tau^{\tau+T_0} - \frac{\partial v_z}{\partial \tau} \int v_z d\tau \\ &= - \frac{\partial v_z}{\partial z} \int v_z dz, \end{aligned}$$

where top line denotes the temporal average over period of the magnetoacoustic wave. For example, we consider the average heating over the sound period and the case where the heating-cooling function depends exclusively on temperature, $L = L(T)$. Making use of notation $\frac{dL}{dT} \equiv L_T$ and ignoring the second order derivative $\frac{d^2 L}{dT^2}$, we rearrange Eq. (13) using equalities

$$\begin{aligned} L_p &= \frac{L_T}{C_V (\gamma - 1) \rho_0}, \quad L_\rho = - \frac{c_0^2 L_T}{C_V (\gamma - 1) \gamma \rho_0} : \\ \frac{\partial \rho_\tau}{\partial t} - \frac{\gamma + 1}{C_V (\gamma - 1) \gamma \rho_0} L_T \overline{\rho_\tau} &\equiv F_{ms} = \alpha \overline{v_z^2}, \quad (14) \end{aligned}$$

where

$$\begin{aligned} \alpha &= \frac{(\gamma - 1) L_T}{4\gamma C^4 c_0^2 C_{A,x} (C^4 - c_0^2 C_{A,z}^2) C_V} \\ &\cdot (3C^8 (C_{A,x} + C_{A,z}) - (\gamma + 1) c_0^6 C_{A,z}^3 \\ &+ C^6 c_0^2 (C_{A,x} + (\gamma - 8) C_{A,z} + 3\gamma C_{A,x}) \\ &+ 2(\gamma - 1) C^2 c_0^4 C_{A,x}^3 \\ &+ C^2 c_0^4 C_{A,z} ((\gamma - 2) c_0^2 - (C_{A,x} - 2(\gamma + 1) C_{A,z}) C_{A,z}) \\ &+ C^4 c_0^2 (c_0^2 ((7 - 2\gamma) C_{A,z} + (\gamma - 4) C_{A,x}) \\ &+ (\gamma + 1) C_{A,z}^2 ((2\gamma - 1) C_{A,x} + C_{A,z}))). \end{aligned}$$

The sign of α coincides with the sign of L_T for any θ and plasma- β . The conditions of acoustic and thermal instabilities are identical and sound

$$L_T > 0.$$

The characteristic time of variation of ρ_τ equals $\frac{C_V (\gamma - 1) \gamma \rho_0}{(\gamma + 1) L_T}$ and should be much larger than the sound period. For taking a proper average over the sound period, the inequality must take place:

$$\frac{(\gamma - 1)^2}{(\gamma + 1)} \gg \frac{L_T T_0 (\gamma - 1)}{C_V \gamma \rho_0}. \quad (15)$$

Also, magnetosound perturbations weakly vary over the period to be a wave process. This imposes $T_0 \ll (DC)^{-1}$, that is,

$$\frac{2(C^4 - c_0^2 C_{A,z}^2)}{C^2 (C^2 - C_A^2)} \gg \frac{L_T T_0 (\gamma - 1)}{C_V \gamma \rho_0}. \quad (16)$$

In the solar corona, the value of γ varies from 1 (isothermal case) to 5/3 (adiabatic case), hence $\frac{(\gamma - 1)^2}{(\gamma + 1)}$ varies from 0 to 0.17. In particular, DOORSSELAERE *et al.* (2011), by use of seismological estimations, found out $\gamma = 1.1$. The ratio $\frac{2(C^4 - c_0^2 C_{A,z}^2)}{C^2 (C^2 - C_A^2)}$ varies from 0.5 to infinity for all β and θ and both fast and slow modes. Hence, the condition (15) ensures (16) with a large margin. The solution to Eq. (14), satisfying zero initial condition, is

$$\overline{\rho\tau} = \frac{C_V(\gamma-1)\gamma\rho_0}{(\gamma+1)L_T} \left(\exp\left(\frac{(\gamma+1)L_T}{C_V(\gamma-1)\gamma\rho_0}t\right) - 1 \right) F_{ms},$$

$$F_{ms} = \alpha \overline{v_z^2}. \quad (17)$$

Impulsive and aperiodic excitation cannot be treated by averaging of evolution equation over the sound period.

4.1. Heating caused by initially sinusoidal perturbation

Before formation of discontinuity of the initially sinusoidal perturbation, that is, for velocity given by Eq. (8), the average squared velocity equals

$$\overline{v_z^2} = \frac{1}{2} e^{2Dz} v_0^2.$$

A half of the average square velocity is in fact wave kinetic energy per unit mass of a plasma. It is constant if $D = 0$. Once discontinuity is formed, the dynamics of kinetic energy depends on two effects: nonlinear attenuation at the shock front and non adiabaticity which

taken alone may enlarge the gas velocity. The average square velocity after formation of discontinuity follows from Eq. (9):

$$\overline{v_z^2} = \frac{\pi^2 \exp(2Dz)}{3(1 + \pi K^{-1}(\exp(Dz) - 1))^2} v_0^2. \quad (18)$$

It tends to a quantity independent from the initial magnitude

$$\frac{1}{3} K^2 v_0^2 = \frac{D^2 C^4 T_0^2}{12\varepsilon^2}$$

when z tends to infinity if $D > 0$ and to 0 if $D < 0$. The case

$$K = \pi \quad (19)$$

is special. It results in the stationary wave forming after formation of discontinuity and constant average squared velocity independent on the distance from a transducer,

$$\overline{v_z^2} = \frac{\pi^2}{3} v_0^2.$$

The dependence of the magnetosound force F_{ms} on z is determined by D and K . Figure 3 shows $\frac{\overline{v_z^2}}{v_0^2} = \frac{F_{ms}}{\alpha v_0^2}$

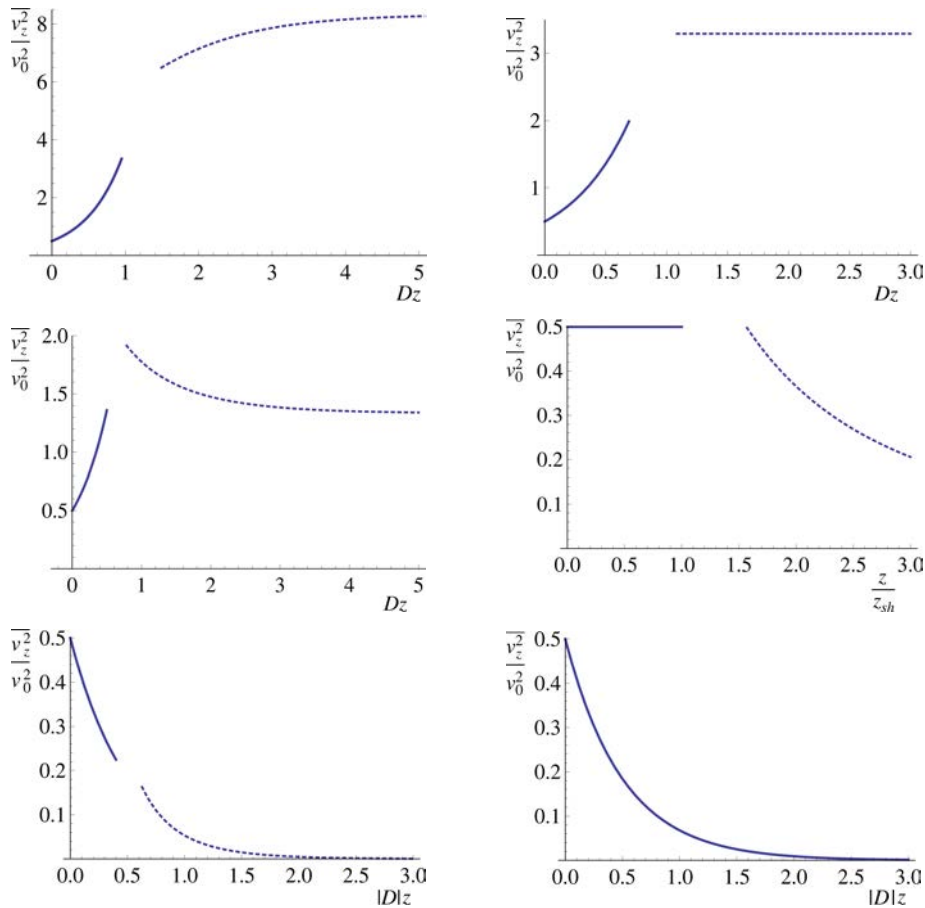

Fig. 3. Ratio $\frac{\overline{v_z^2}}{v_0^2} = \frac{F_{ms}}{\alpha v_0^2}$. Top row: $K = 5$ (left panel) and $K = \pi$ (right panel), middle row: $K = 2$ (left panel) and $K = 0$ (right panel, this is a limiting case described by Eqs (21), (22)), bottom row: $K = -\pi/3$ (left panel) and any $K < -\pi$ (right panel). Solid lines relate to the distances before the formation of a discontinuity, and the dashed lines relate to the wave forms with shock fronts.

before and after formation of a discontinuity. $K > 0$ is the acoustically active case of a flow. Equation (7) describes also the neutral flows with $K = 0$, $D = 0$, and $Z = z$. In this case, the solution to Eq. (6) which is sinusoidal at $z = 0$, reads

$$v_z = v_0 \sum_{n=1}^{\infty} \frac{2J_n(2n\pi z \varepsilon v_0 / C^2 T_0) \sin(2\pi n \tau / T_0)}{2n\pi z \varepsilon v_0 / C^2 T_0}, \quad (20)$$

and, hence, the kinetic energy per unit mass remains constant before formation of discontinuity:

$$\overline{v_z^2} = \frac{1}{2} v_0^2. \quad (21)$$

It is valid if

$$0 < z < z_{sh} = \frac{C^2 T_0}{2\pi \varepsilon v_0}.$$

After formation of the shock front, at $z \geq z_{sh}$, the average square velocity equals (RUDEKNO, SOLUYAN, 1977)

$$\overline{v_z^2} = \frac{\pi^2 v_0^2}{3 \left(1 + \frac{z}{z_{sh}}\right)^2}. \quad (22)$$

4.2. Heating caused by initially saw-tooth perturbation

The case with already formed at a transducer discontinuity differs from the previous one: the discontinuity remains at all distances from a transducer independent from acoustical activity. Equation (11) results in the average squared velocity as

$$\overline{v_z^2} = \frac{1}{3} \left(\frac{v_0 e^{Dz}}{1 + K^{-1}(e^{Dz} - 1)} \right)^2.$$

This result also readily follows from the squared series (12) averaged over the sound period. The limiting value of average squared velocity when z tends to infinity, equals

$$\overline{v_z^2} = \frac{1}{3} K^2 v_0^2 = \frac{D^2 C^4 T_0^2}{12 \varepsilon^2}$$

if $D > 0$ and 0 if $D < 0$. The character of variation of $\overline{v_z^2}$ with z in an acoustically active flow depends on K : if it is smaller than one, the average square velocity decreases, and if K is larger than one, it enlarges with z tending to the limit at infinite z . The case

$$K = 1 \quad (23)$$

yields the stationary wave form and constant average squared velocity is independent from the distance from a transducer,

$$\overline{v_z^2} = \frac{1}{3} v_0^2.$$

The special case conditioned by Eq. (23) fits the equality

$$\frac{C_V \rho_0 v_0}{c_0 L_T} = \frac{(\gamma - 1) C^3 (C^2 - C_A^2) (2C^2 - c_0^2 - C_A^2)}{e^*},$$

where

$$e^* = 2\gamma c_0 (c_0^2 C_{A,z}^2 - C^4) (3c_0^2 + C_A^2 + \gamma(C_A^2 - C^2) - 4C^2).$$

Figure 4 shows values $\frac{C_V \rho_0 v_0}{c_0 L_T}$ ensuring stationary wave form and magnetosound force independent from the distance from the transducer as functions of plasma- β and θ .

The conclusions based on Fig. 4 are valid also for initially sinusoidal perturbations with developed discontinuities. The magnetoacoustic force of heating (Fig. 3, thin lines) is analogous to the case of harmonic initially perturbations, with substitution of K from Subsec. 4.1 with K/π . The difference is in the description of the wave form and nonlinear effects before formation of discontinuity which does not always form in the first case. An excess density and temperature in the isobaric entropy mode are related in the following manner

$$\frac{\rho_7}{\rho_0} = -\frac{T_7}{T_0}.$$

In an acoustically active flow, T_7 is unusually negative, and ρ_7 is positive.

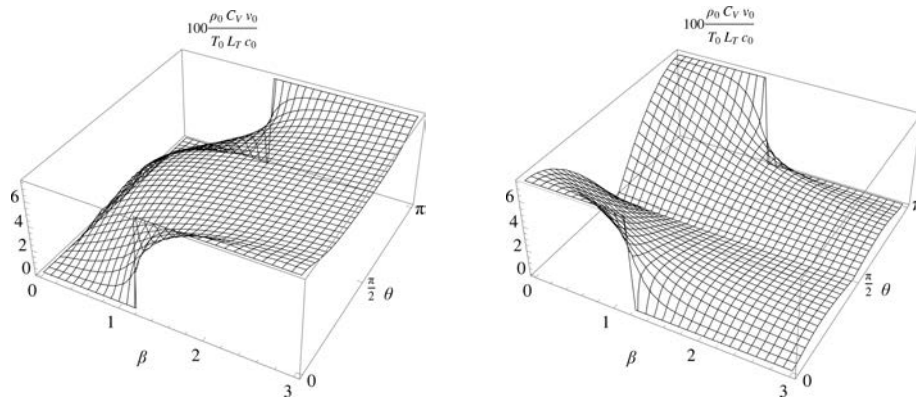

Fig. 4. Values $\frac{C_V \rho_0 v_0}{c_0 L_T}$ ensuring stationary wave form and magnetosound force of heating independent on a distance from a transducer. Acoustically active flow. Fast magnetosound perturbations (left panel) and slow magnetosound perturbations (right panel).

5. Concluding remarks

The starting point is the conservation system of PDE in ideal MHD equations. Ideal magnetohydrodynamics is valid if temporal and spatial scales of a flow are much larger than gyro-kinetic scales. It refers to the single fluid model dealing with macroscopic equilibrium quantities and equal temperatures of electrons and ions. MHD system does not consider relativistic, quantum effects and displacement current in the Ampere’s law (KRALL, TRIVELPIECE, 1973; FREIDBERG, 1987). It approximates well the majority of astrophysical gases, such as magnetospheres of Earth, neutron stars, and solar atmosphere. The equation of state for an ideal gas is valid in the majority of astrophysical applications. We do not discuss effects connected with mechanical viscosity and thermal conduction of a plasma. The impact of thermal conduction on the magnetosound wave propagation has been considered by NAKARIAKOV *et al.* (2000). The damping mechanisms may alter conditions of acoustical activity and influence magnetoacoustic heating.

Previous results by the author concerned magnetoacoustic heating associating with the harmonic in the all space perturbations (PERELOMOVA, 2018a; 2018b). In this study, we consider nonlinear distortions of wave perturbations and nonlinear phenomena associating with non adiabaticity of magnetosound waves before and after formation of discontinuities. A plasma is an open system. Some generic function L is responsible for inflow of external energy and radiation losses. The scenario depends actually on the balance between the degree of deviation from adiabaticity described by L , and nonlinear distortions, which in turn depend on a magnitude of wave perturbations, parameter of nonlinearity and the wave speed. These two latter quantities are functions of plasma- β and θ . This makes analysis of propagation of periodic initially wave forms fairly difficult. A discontinuity may form even in the case of out coming energy in a weakly damping plasma (Subsec. 3.1). When the inflow of energy outweighs damping, discontinuity forms, and nonlinear attenuation at the shock front takes place. The analysis reveals that the harmonic at a transducer perturbation of velocity may evolve in different ways: the discontinuity may not form at all; the discontinuity forms and the magnitude of velocity achieves some limiting value (zero or positive which does not depend on initial magnitude) far from transducer or remains constant. The limiting values also depend on the plasma- β and an angle between the equilibrium magnetic field and the wave vector. The distance of discontinuity formation in initially periodic perturbations depends on plasma- β and θ as well as on the initial amplitude and period of perturbations. The average magnetosound force of heating is proportional to v_z^2 and hence also tends to some limiting value far from the transducer. The conditions of thermal and

adiabatic instabilities are identical in the case $L(T)$, which is considered as an example in this study, but in general they differ. The magnetoacoustic heating excited by the harmonic in all space perturbations in the particular cases $L(p)$ and L_ρ has been considered by the author in the article (PERELOMOVA, 2018).

An average excess density in the entropy mode which equals zero at $t = 0$ is generally governed by equation

$$\begin{aligned} \bar{\rho}_\gamma &= \frac{c_0^2}{(\gamma+1)L_\rho} \left(1 - \exp\left(-\frac{(\gamma+1)L_\rho t}{c_0^2}\right) \right) F_{ms}, \quad L_\rho \neq 0, \\ \bar{\rho}_\gamma &= F_{ms} t, \quad L_\rho = 0. \end{aligned} \tag{24}$$

Equation (24) is valid for periodic excitors with the magnetosound force $F_{ms}(z)$ and quasiperiodic excitors with F_{ms} which depends on z and weakly on t . While the sign of ρ_γ is determined by the sign of F_{ms} (coinciding with the sign of $c_0^2 L_p + L_\rho$), the character of its dynamics depends on the sign of L_ρ . In thermally stable flows $L_\rho > 0$, ρ_γ tends to $\frac{c_0^2}{(\gamma+1)L_\rho} F_{ms}$ and grows infinitely in thermally active flows. Figure 5 roughly represents the dynamics of $\bar{\rho}_\gamma$ at any z . It remains positive in isentropically unstable flows corresponding to negative excess temperature.

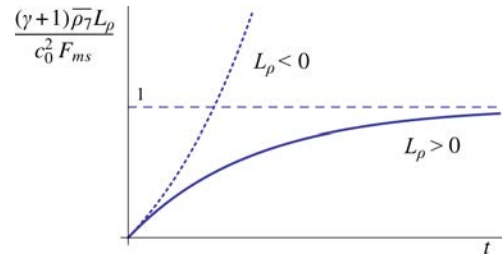

Fig. 5. Schematic dynamics of $\bar{\rho}_\gamma$ at any distance from a transducer z . F_{ms} is positive in acoustically active flows $c_0^2 L_p + L_\rho > 0$ and negative if $c_0^2 L_p + L_\rho < 0$. The sign of L_ρ responses for thermal stability (L_ρ is negative in thermally unstable flows).

The results may be addressed to different kinds of a plasma, including cold molecular intersellar gas and hot atomic plasma, to various magnitudes of the equilibrium magnetic field, and to different kinds of the function $L(p, \rho)$ which is zero in equilibrium (ROSNER *et al.*, 1978; VESECKY *et al.*, 1979; NAKARIAKOV *et al.*, 2000). They may be useful in remote studies of plasma’s features and processes in it. Magnetosound heating is a slow process suited very well for long observations. This compares favorably with wave perturbations during remote observations. We focus on the particular case L depending linearly on temperature T . Other kinds of $L(p, \rho)$ may be readily considered. The only difference is that they yield different coefficients in dynamic equations for wave perturbations and appropriate. The main features of heating depend on whether the flow is thermally and/or isentropically stable or

not. Inclusion of the second order derivatives of $L(p, \rho)$ would allow to consider the features of heating close to and at extrema of L . In the case of periodic excitors, the second order derivatives contribute in the magnitude of the average magnetosound force of heating which is proportional to the average squared velocity in the MHD wave.

References

1. BALLAI I. (2006), Nonlinear waves in solar plasmas—a review, *Journal of Physics: Conference Series*, **44**: 20–29, doi: 10.1088/1742-6596/44/1/003.
2. CHIN R., VERWICHTE E., ROWLANDS G., NAKARIAKOV V.M. (2010), Self-organization of magnetoacoustic waves in a thermal unstable environment, *Physics of Plasmas*, **17**(32): 107–118.
3. FIELD G.B. (1965), Thermal instability, *The Astrophysical Journal*, **142**: 531–567, doi: 10.1086/148317.
4. FREIDBERG J.P. (1987), *Ideal magnetohydrodynamics*, Plenum Press, New York.
5. GEFFEN N. (1963), Magnetogasdynamic flows with shock waves, *The Physics of Fluids*, **6**(4): 566–571.
6. HAMILTON M., MORFEY C. (1998), Model equations, [in:] *Nonlinear acoustics*, Hamilton M., Blackstock D. [Eds], pp. 41–63, Academic Press, New York.
7. KELLY A., NAKARIAKOV V.M. (2004), Coronal seismology by MHD autowaves, [in:] *Proceedings of SOHO 13 Waves, Oscillations and Small-Scale Transients Events in the Solar Atmosphere: a joint view from SOHO and TRACE*, Lacoste H. [Ed.], Vol. 547, pp. 483–488.
8. KRALL N.A., TRIVELPIECE A.W. (1973), *Principles of plasma physics*, McGraw Hill, New York.
9. LEBLE S., PERELOMOVA A. (2018), *The dynamical projectors method: hydro and electrodynamics*, CRC Press.
10. MAKARYAN V.G., MOLEVICH N.E. (2007), Stationary shock waves in nonequilibrium media, *Plasma Sources Science and Technology*, **16**(1): 124–131, doi: 10.1088/0963-0252/16/1/017.
11. MOLEVICH N.E. (2001a), Amplification of vortex and temperature waves in the process of induced scattering of sound in thermodynamically nonequilibrium media, *High Temperature*, **39**(6): 884–888, doi: 10.1023/A:1013147207446.
12. MOLEVICH N.E. (2001b), Sound amplification in inhomogeneous flows of nonequilibrium gas, *Acoustical Physics*, **47**(1): 102–105, doi: 10.1134/1.1340086.
13. NAKARIAKOV V.M., MENDOZA-BRICEÑO C.A., IBÁÑEZ M.H. (2000), Magnetoacoustic waves of small amplitude in optically thin quasi-isentropic plasmas, *Astrophysical Journal*, **528**(2): 767–775, doi: 10.1086/308195.
14. OJHA S.N., SINGH A. (1991), Growth and decay of sonic waves in thermally radiative magnetogasdynamics, *Astrophysics and Space Science*, **179**(1): 45–54.
15. OSIPOV A.I., UVAROV A.V. (1992), Kinetic and gasdynamic processes in nonequilibrium molecular physics, *Soviet Physics Uspekhi*, **35**(11): 903–923.
16. PARKER E.N. (1953), Instability of thermal fields, *The Astrophysical Journal*, **117**: 431–436.
17. PERELOMOVA A. (2006), Development of linear projecting in studies of non-linear flow. Acoustic heating induced by non-periodic sound, *Physics Letters A*, **357**(1): 42–4, doi: 10.1016/j.physleta.2006.04.0147.
18. PERELOMOVA A. (2010), Interaction of acoustic and thermal modes in the gas with nonequilibrium chemical reactions. Possibilities of acoustic cooling, *Acta Acustica united with Acustica*, **96**(1): 43–48, doi: 10.3813/AAA.918254.
19. PERELOMOVA A. (2012), Nonlinear influence of sound on vibrational energy of molecules in relaxing gas, *Archives of Acoustics*, **37**(1): 89–96.
20. PERELOMOVA A. (2014), Thermal self-action effects of acoustic beam in a vibrationally relaxing gas, *Applied Mathematical Modelling*, **38**(23): 5684–5691, doi: 10.1016/j.apm.2014.04.055.
21. PERELOMOVA A. (2016a), On the nonlinear effects of magnetoacoustic perturbations in a perfectly conducting viscous and thermo-conducting gas, *Acta Physica Polonica A*, **130**(3): 727–733, doi: 10.12693/APhysPolA.130.727.
22. PERELOMOVA A. (2016b), On the nonlinear distortions of sound and its coupling with other modes in a gaseous plasma with finite electric conductivity in a magnetic field, *Archives of Acoustics*, **41**(4): 691–699, doi: 10.1515/aoa-2016-0066.
23. PERELOMOVA A. (2018a), Magnetoacoustic heating in a quasi-isentropic magnetic gas, *Physics of Plasmas*, **25**: 042116, doi: 10.1063/1.5025030.
24. PERELOMOVA A. (2018b) Magnetoacoustic heating in nonisentropic plasma caused by different kinds of heating-cooling function, *Advances in Mathematical Physics*, **2018**: Article ID 8253210, 12 pages, doi: 10.1155/2018/8253210.
25. PERELOMOVA A. (2019), Propagation of initially sawtooth periodic and impulsive signals in a quasi-isentropic magnetic gas, *Physics of Plasmas*, **26**(5): 052304, doi: 10.1063/1.5093390.
26. ROSNER R., TUCKER W.H., VAIANA G.S. (1978), Dynamics of the quiescent solar corona, *Astrophysical Journal*, **220**: 643–665, doi: 10.1086/155949.
27. RUDENKO O.V., SOLUYAN S.I. (1977), *Theoretical foundations of nonlinear acoustics*, Plenum, New York.
28. SHARMA V.D., SINGH L.P., RAM R. (1987), The progressive wave approach analyzing the decay of a saw-

- tooth profile in magnetogasdynamics, *Physics of Fluids*, **30**(5): 1572–1574, doi: 10.1063/1.866222.
29. SINGH L.P., SINGH R., RAM S.D. (2012), Evolution and decay of acceleration waves in perfectly conducting inviscid radiative magnetogasdynamics, *Astrophysics and Space Science*, **342**(2): 371–376, doi: 10.1007/s10509-012-1189-0.
30. VAN DOORSSELAERE T., WARDLE N., DEL ZANNA G., JANSARI K., VERWICHTE E., NAKARIAKOV V.M. (2011), The first measurement of of the adiabatic index in the solar corona using time-dependent spectroscopy of HINODE/EIS observations, *The Astrophysical Journal Letters*, **727**(2): L32, doi: 10.1088/2041-8205/727/2/L32.
31. VESECKY J.F., ANTIOCHOS S.K., UNDERWOOD J.H. (1979), Numerical modeling of quasi-static coronal loops. I – Uniform energy input, *Astrophysical Journal*, **233**(3): 987–997.
32. ZAVERSHINSKY D.I., MOLEVICH N.E. (2014), Alfvén wave amplification as a result of nonlinear interaction with a magnetoacoustic wave in an acoustically active conducting medium, *Technical Physics Letters*, **40**(8): 701–703, doi: 10.1134/S1063785014080288.
33. ZAVERSHINSKY D.I., MOLEVICH N.E., RYASHCHIKOV D.S. (2015), Structure of acoustic perturbations in heat-releasing medium, *Procedia Engineering*, **106**: 363–367, doi: 10.1016/j.proeng.2015.06.046.