

MULTI CRITERIA DECISION MAKING MODEL FOR PRODUCING MULTIPLE PRODUCTS AT THE SAME TIME

Rami Mokao

Decision Support Systems Master, Higher Institute for Applied Science & Technology, Syria

Corresponding author:

Rami Mokao

Decision Support Systems Master

Higher Institute for Applied Science & Technology

Damascus, Syria

phone: +963 0956 221 486, 0938 884 417

e-mail: rami.mokao@hotmail.com

Received: 8 March 2019

Accepted: 15 May 2020

ABSTRACT

The Decision Makers in the production organizations, which produce multiple different products at the same time, set the priorities for what the organization desires to produce. This priority is sorting the products in order to schedule the production based on these priorities. The production organizations receive a huge number of orders from different customers, each order contains many products with close delivery dates. The organization aims to produce multiple different products at the same time, in order to satisfy all customers by delivering all orders at the right time. This study will propose a method to prioritize the production to produce a multiple different products at the same time, the production lines will produce multiple different products. This method will prioritize the products using Multi Criteria Decision Making technique, and prioritize the production operations using a new algorithm called Algorithm for Prioritization of Production Operations. In addition, the study will provide an algorithm for production scheduling using the production priority calculated based on the proposed method. The study will also compare the scheduling based on the priority rules and based on the proposed method through total production time and the variety of products produced.

KEYWORDS

Production priority, priority rules, production scheduling, time table.

Introduction

The change in the environment and the diversity in customer requirements leads to a change and continuous development in the business and the industries. This requires the production organization to be flexible and interactive in the production processes in order to meet the customer needs in an optimal manner and thus ensure the continuity of the organization and the profit. The production organization described as a production system used for transforming input into output. The production system defined as an integrated set of resources to carry out a range of raw materials manufacturing processes in order to obtain a product [1]. The production organization aim these days to satisfy customers' needs by producing a wide range of products and meeting delivery dates. The arrival orders to the produc-

tion organization are characterized by the abundance and diversity of the products and the convergence of the delivery dates, which drive the organization to produce multiple different products at the same time in order to satisfy all customers by providing a wide range of products and delivering all orders at the same time. The production system can be divided into single-stage and multi-stage system [2]. The single-stage system requires one operation for each job, whereas in a multi-stage system there are jobs that require operations on different machines. Single-stage systems involve either a single machine referred to as the single machine scheduling problem, or m machines in parallel referred to as the parallel machine scheduling problem. In multi-stage systems, there are three types of basic shop scheduling problems: the flow shop scheduling (FSS) problem, the job shop scheduling (JSS) problem, and the open

shop scheduling (OSS) problem [3]. In other way reference [4] classified the production system into one-stage (one processor), one-stage (parallel processors), multistage (flow shop) and multistage (job shop).

The production organization schedule the production on the available resources (machines), and the Production Scheduling can be defined as the allocation of available production resources over time to satisfy some set of criteria's [4]. Also the scheduling defined by [5] as determining the sequence in which the operations are executed to produce a schedule, which specifies the operations that execute in each step.

Reference [6] classified scheduling into Static scheduling involve assigning a set of jobs on machines with time constraints applied to both jobs and machines before production begins, and Dynamic scheduling deal with revising a schedule to maintain optimality during processing when some unexpected events occur.

The theory of scheduling contains unlimited number of problem types [7]. And the scheduling problem is the problem of determining the order in which the operations execute [5]. The reference [7] mentioned and classified scheduling problem.

Reference [8] classified the scheduling problems as (Job Shop, Flow Shop, and Open Shop). References [9] and [10] classified the scheduling problem to uncertain scheduling and Deterministic scheduling, the uncertain scheduling contains (Fuzzy scheduling, Stochastic scheduling) and the Deterministic scheduling contain (Single machine scheduling problem, Multiple machine scheduling problem), the Multiple machine scheduling problem contains (Parallel machine, Flow shop, Job shop).

The production organization have a wide range of products each product is different than the other through features, each product contain components each component have one or many production operation, the products may share the same component and may share the same machine. The organization have m machines M_j ($j = 1, \dots, m$), these machines have to process n operations (O_i, \dots, O_{ni}) each operation have processing time t , each operation should be processed on one machine, and there are precedence relationships between the components in each product, and there are precedence relationships between the operations in each product.

Usually a technological plan designed to manufacture each product; it includes all the needed manufacturing processes with estimated time to each process and includes the logical sequencing for these processes. The production management in the production organizations according to their productive abil-

ities (the available fixed resources quality and quantity) puts a master production plan proportional with the diversity and the quantities of the desired products, taking into consideration the customer desire and the need to observe the delivery date for each product. The production plan consists of the needed number of products to be produced. Each product in the plan has a specific delivery time and a production quantity (ordered quantity). The organization prioritize these products to arrange them in the production plan in order to generate a timetable to each machine. The timetable contains the components that are needed to be processed on these machines and contains the operations start and end time.

The process began with the production organization receive a huge number of variant orders from different customers, each order contain different products with different quantities. The production organization don't want to cancel or delay delivering the orders, therefore it will produce all the products together through achieving the high occupancy for the machines. When achieving the high occupancy for the machines it leads to produce all orders, satisfy all customers' needs and increase profits. In order to satisfy all customers' requests the organization needs to produce all the products in the orders together and deliver the ordered quantity at the right time. However the organization could not start the production for all the arrived orders at the same time because there will be a conflict in the machines schedule (we may find several operations from several products share the same machine), if the products production operation are processed in different machines it will not be a problem, we will produce all the products together at the same time, but if we have a conflict in the machines we can't produce all orders together. Therefore, we need to prioritize the products in the arrival orders in order to start the production. So we need a prioritization method that take into consideration producing multiple different products at the same time (producing several component from different products at the same time, the production lines will produce multiple products together). As an example if we have two products, the first one have the highest priority, the prioritization method prioritizes the production to produce in the first day 12 pieces from the first product and 9 pieces from the second product, these quantities are produced together, it mean we could find operations from both products processed together in the machines, the difference in the produced quantities is a result of the prioritization (the need to produce more quantities from the product that have the highest priority). At the end of the first day, we produce quantities from

both products. In reality, we have a huge number of orders and a wide range of products and the prioritization method should consider this. After that, the timetable will be generated based on the production priority, and the production organization will start the production based on the timetable.

This paper aims to provide a prioritization method to produce multiple different product at the same time by producing several component from different products (the production lines will process multiple operation from multiple products). To achieve that goal we need to prioritize the production, to do that we need to differentiate between the products in the arrival orders in terms of importance, in order to do that we will depend on the arrived orders information (Product, Production Quantities, Order Date, Delivery Date and Order Processing Time). Therefore, we will prioritize the products based on a number of variables (orders information) using Multi Criteria Decision Making (MCDM) technique, and we need to prioritize the production operation on the production lines using a new algorithm for prioritizing the production operations (Algorithm for Prioritizing the Production Operations – APPO).

The proposed method combines the MCDM and the new algorithm APPO in order to sort the production priority, and the production priority is calculated from the products priority and the operation priority; and the timetable will be generated based on operation priority.

Literature review

A number of surveys provide details about production scheduling. Reference [11] presented a survey about the papers that covers the production scheduling and scheduling approaches. Reference [12] presented a survey about the approaches mathematical programming, dispatching rules, expert systems, neural networks, genetic algorithms, and inductive learning. Reference [4] presented a classification for various scheduling problems, to review important theoretical developments for these problem classes, and to contrast the currently available theory with the practice of production scheduling. Reference [13] presented a survey about a fuzzy scheduling. Reference [14] presented a survey which covers most of the solving techniques of Job Shop Scheduling (JSS) problem. Reference [15] reviewed the contributions in the formulation and solution of scheduling problems focusing on the task of sequencing a set of jobs on a group of machines, in a job shop situation. Reference [10] presented a survey about the scheduling

problems with multiple objectives. Reference [16] provided a comprehensive review of the literature on job shop scheduling research involving setup times, and presented the job shop scheduling problems with non-batch (job) setup times and with batch setup times.

Reference [17] examined the contribution that Operational Research has made in relation to the various phases of production scheduling and to speculate on what areas hold most promise for future efforts. Reference [18] presented an extended view of scheduling that unifies the traditional definition used in operations research and a number of key aspects of real-world scheduling, and an enhanced framework for scheduling has been proposed using three principles (Partiality, Predictiveness, Temporality) that can be used to explain the overall quality of scheduling results in practice.

Reference [19] developed a Machine Loading Sequencing Genetic Algorithm (MLSGA) model to improve the production efficiency, and the proposed production scheduling system will take into account the quality of product and service, inventory holding cost, and machine utilization. Reference [20] analyzed and discussed the problem of production scheduling and established a mathematic model of the problem to cope with the production scheduling problems with the characteristics of NP-hard via the genetic algorithm. Reference [21] proposed an Innovative Genetic Algorithm-based approach called IGA, the algorithm indicates the potential improvement in flexible job-shop scheduling problem especially with multiple identical machines under a resource constrained environment. Reference [22] focused on solving the flexible job shop scheduling problem where sequence dependent setup times are taken into account, and proposed a hybrid genetic algorithm to minimize two kinds of objective functions makespan (completion time) and aggregate objectives function. Reference [23] aimed to optimize the job shop scheduling problem using simulation and genetic algorithm, and presents a simulation-based genetic algorithm approach for job shop scheduling problem, with an objective to minimize mean tardiness and makespan (maximum completion time). Reference [24] proposed a new Fundamental Tree Algorithm in optimizing production scheduling in surface mining, and a mathematical programming model is developed using linear variables.

Regarding artificial neural networks, the reference [25] presented an artificial neural network approach to solve production scheduling problem in order to determine the sequence of operations. Reference [26] presented an artificial neural network

(ANN) based real-time production Scheduling, the ANN based novel expert system is developed for solving the problem of real-time production scheduling of industrial process with multi-production-stage and discrete event operations.

Reference [27] presented an optimization model for the production scheduling, and a prototype scheduling tool has been developed based on a tabu search heuristic to solve the model. Reference [28] examined near-optimal solution methodologies for job shop scheduling, and presented a new algorithm that combines backward dynamic programming for solving low-level sub problems and interleaved conjugate gradient method for solving the high-level problem. Reference [29] presented a dispatching algorithm to solve the flexible job-shop scheduling problem with transfer batches and the objective of minimizing the average tardiness of production orders.

Regarding the priority rules, the reference [30] defined the Priority Rules and the Dispatching Rules as a simple technique by which a number (or value) is assigned to each job according to the method and the job with minimum value is selected. Reference [31] presented a survey on heuristic priority rule-based in job shop scheduling. Reference [32] proposed new dispatching rules for scheduling in job shop. The priority rules as classified in many references [33, 34] and [35] to:

1) Single Priority Rules:

Choosing a single rule and prioritizing the products based on it, where the single priority rule depends on a single variable, example SPT – Shortest Processing Time rule depends on the processing time.

2) Combined Priority Rules:

Choosing more than one rule (two rules) and prioritizing the products based on the selected rules combined together (at the same time), the combined priority rule depends on multiple variables at the same time. Example FIFO/SPT (First In First Out/Short Processing Time) rules prioritize the products based on the Arrival date. The first arrival job will be processed first and in case we have two or more jobs arrived at the same time and we do not know which one to begin with, we apply the second rule that is short processing time rule, this combined rule depends on two variables, which are (arrival date, processing time). Reference [36] provided a simulation tool for evaluating the customers orders through 10 famous priority rules based on the Total Flow Time (Makespan) and the Total Processing Time, these rules are (FIFO, LIFO, SPT, LPT, EDD, LRNOP, GRNOP, SRPT, LRPT, SIRO). Reference [33] compared and evaluated 30

of the most famous single priority rules and 10 famous combined priority rules, and reached a conclusion that the combined priority rule is far better than the single priority rule. Reference [37] compared 10 famous priority rules, and evaluate the priority rules that affects the defined production goals. And they reached that the LOPR rule is the best between the rules that they mentioned, and the EDD rule is the best rule for minimizing the Total Flow Time (Makespan).

Regarding to the Multi Criteria Decision Making [38] provided a comprehensive survey of some methods for eliciting and processing data for MCDM problems. Reference [39] presented a case study to select the best solution from multiple alternatives, they presented a software tool that assists in the analyzing of multi criteria decisions, the software tool sorts the alternatives. The researchers at first defined a set of alternatives, put the criterias and put marks to each alternative based on each criteria. Reference [40] compared the multi criteria decision-making methods (WSM, WPM, TOPSIS, AHP, PROMETHEE, ELECTRE I), and chose the ranking methods that aim to select the optimal solution from multiple alternatives. They reached that most of the studied methods agreed to specify the alternative with the higher value, and the result between the methods (TOPSIS, PROMETHEE) were similar. Reference [41] provided a model for evaluating the result by using multi criteria decision making methods and choosing the optimal alternative, they chose the alternative, defined the criterias and their weight, and they used a fuzzy scale to evaluate the alternatives based on the criterias. In addition they used 4 other methods to sort the alternatives (COPRAS, TOPSIS, ELECTRE, VIKOR), and they concluded that the methods (ELECTRE, VIKOR) results are similar. Reference [42] evaluated the priority rules to choose the best priority rules using multi criteria decision making methods, and they used AHP- Analytical Hierarchy Process to calculate the criteria weights based on the pairwise comparison, and the method (TOPSIS) was used for evaluating and selecting the best priority rule. Reference [43] compared the multi criteria decision making methods that aim to select the optimal solution from multiple solutions (alternatives), the methods are (SAW, TOPSIS, ELECTRE III, PROMETHEE II and TODIM AHP, PROMETHEE I and ELECTRE I). In addition, they studied the correlation between these methods and reached that there is a correlation between the methods (ELECTRE I, PROMETHEE I, TODIM). Reference [44] presented different types of transformation and nor-

malization of data that are available for popular MC-DA methods, such as SAW or TOPSIS.

Research methodology

To achieve the goal of producing multiple different products at the same time, the production lines will focus on the processing operations (processing operations on the components) not on the products, it means the production lines will process multiple operations from multiple components from different products at the same time. As we mentioned earlier the organization could not start the production for all the arrived orders at the same time because there will be a conflict in the machines schedule (we may find several components from several products share the same machine), that's why we can't produce all orders together. Therefore we need to start processing the operations from the most important products, after that the less important and the less. So we have to sort the products (Prioritize the products), through differentiating between products based on the information arrived with the orders (Production Quantity, Order Date, Delivery Date and Order Processing Time). To prioritize the products we will use Multi Criteria Decision Making technique, and to process multiple operations we need to prioritize the production operation on the production lines using a new algorithm for prioritizing the production operations (Algorithm for Prioritizing the Production Operations).

We will start with prioritizing the products using MCDM.

Prioritize the products using multi criteria decision making

Decision Making is the process of constructing the choice criteria (or functions) and strategies and use them to select a decision from a set of possible alternatives [45]. Decision making process depends on information from the decision environment and a number of variables that form the input for the decision model, the decision maker through this information will build the decision model that helps to make his decision. There are two types of information about the variables that are useful for production process:

- 1) External Information: is information related to the arrival orders, like the products that need to be produced and the quantities and the delivery date.
- 2) Internal Information: is information related to the production organization floor, like the production capacity and machine quantity.

Based on the external and internal information we can get the variables that we can depend on in the production prioritization process (Production Quantity, Order Date, Delivery Date and Order Processing Time). In addition, the internal information are (Machine Types, Machine Quantity, Production Shift Time and Production Capacity for Machines).

In our case we have a set of alternatives (the products in the arrival orders), we need to sort (prioritize) them based on a number of weighted criterias that covers the variables related to arrival orders, in addition taking into consideration the decision maker preferences. The Multi Criteria Decision Making technique which is considered a useful tool to help the decision maker to choose the best decision between number of alternatives.

The researchers [46, 47], and [39] mentioned the steps for decision analysis as below:

- 1) Define the alternatives (in our case the products).
- 2) Define set of criterias that are related to the decision problem and cover all the variables (these criterias will be used to evaluate the alternatives).
- 3) Define the criterias weights, which represents the relative importance for each criteria.
- 4) Normalize the alternatives values based on each criterias.
- 5) Calculate the weight for each alternative value.
- 6) Calculate the sum of weights for each alternative.
- 7) Sort the alternative based on the calculated weighted sum for each alternative.

The priority for the alternatives (products) will be sorted based on the sum of the weights for each alternative. The decision maker preference is represented through the criterias weights, which he chooses. Let us explain an example about sorting the products priority for multiple different products in a number of arrival orders as the Table 1.

Table 1
Represent the arrival orders details.

Products	Production quantity	Order date	Delivery date	Processing time (minutes)
A	80	05/2/2018	08/4/2018	2777
A	100	10/1/2018	20/5/2018	3437
B	60	10/1/2018	10/5/2018	8056
C	90	05/1/2018	17/4/2018	11241

Noting that the processing time is the total processing time for the ordered quantity to each product.

The steps for prioritizing the products will be as below:

- 1) Define the alternatives: we have 4 alternatives because we have four products in the arrived orders (A, A, B, C).

2) Define the criterias that we have to sort the alternative based on it:

In addition, we should determine the type of each criteria (beneficial, non-beneficial). The beneficial criteria: the grater the value is, the better the alternative and the opposite for the non-beneficial. As shown in Table 2.

3) Define the criterias weights, which represents the importance of each criteria:

The decision maker will determine the criterias weights based on his preference, noting that the total weights should be 100% as shown in Table 2. The decision maker could use the AHP model to choose suitable weights for all criterias as the researcher presented [48].

4) Normalize the alternatives values based on each criteria:

We calculate the normalization for the alternatives values based on each criteria as shown in Table 3, using the below formulas [49]:

• Beneficial:

$$r_{ij} = \frac{r_{ij} - r_{ij}^{\min}}{r_{ij}^{\max} - r_{ij}^{\min}} \tag{1}$$

• Non-beneficial:

$$r_{ij} = \frac{r_{ij}^{\max} - r_{ij}}{r_{ij}^{\max} - r_{ij}^{\min}} \tag{2}$$

Noting that the r_{ij} is the normalization value for the alternative i on criteria j , example $r_{11} = 0.5$.

5) Calculate the weight for each alternative value (after normalization):

By multiplying the alternative value with the criteria weight ($r_{ij} \times w_j$), as shown in Table 4.

6) Calculate the weighted sum for each alternative: We sum the criterias values from step 5 to each alternative ($\sum r_{ij}$) as Table 5 shows.

7) Prioritize the products: We set the products priority based on sorting the calculated weighted sum, the highest percentage will have the highest priority as shown in Table 5.

Table 2
The criteria and its type and weight.

	Criteria	Criteria type	Criteria weight
C1	Quantity: the maximum amount of production will have the highest priority.	beneficial	25%
C2	FIFO-First In First Out: the earliest arrival date will have the highest priority.	non-beneficial	15%
C3	EDF-Earliest Deadline First: the earliest delivery date will have the highest priority.	non-beneficial	30%
C4	SPT-Short Processing Time: the shortest processing time will have the highest priority.	non-beneficial	15%
C5	Decision Maker Criteria: the decision maker will sort the products using this criteria.	beneficial	15%

Table 3
Normalized values.

Criteria	C1	C2	C3	C4	C5
Products	Quantity	FIFO	E.D.F	SPT	Decision maker criteria
A	0.5	1	0	1	0
A	1	0.5	1	0.922	0.5
B	0	0.5	0.667	0.376	0.5
C	0.75	0	0.333	0	1

Table 4
Calculate the weight for each alternative.

Criteria	C1	C2	C3	C4	C5
Products	Quantity	FIFO	E.D.F	SPT	Decision maker criteria
A	0.125	0.15	0	0.15	0
A	0.25	0.075	0.3	0.138	0.075
B	0	0.075	0.2	0.057	0.075
C	0.1875	0	0.1	0	0.15

Table 5
Products priority.

Product	Total	Priority
A	0.425	3
A	0.838	1
B	0.4065	4
C	0.4375	2

At this point, the products are given a priority based on multiple variables.

After that we will prioritize the operations in all products. We represent the product as a tree using the Generalized Trees graph, and we call it a product tree. The product tree is a set of elements (operations) we call them nodes, they are connected to each other with links that represent the precedence relationships between nodes and we call the top node the root of the tree, we call the nodes that don't have any son a leaf, and we call the sequence of the nodes from the root to the leaf a branch, the tree is Hierarchically organized and don't have a closed circle.

The Fig. 1 represents the operation tree for the product *A* & *C*.

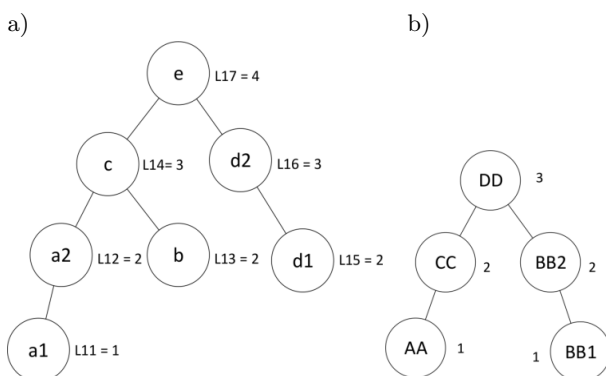

Fig. 1. The operations tree for the product: a) *A*, b) *C*.

Noting that there is a priority between the operations inside the same product, it is the same as the precedence relationship between operations, in Fig. 1a the operation *a2* will not start until the operation *a1* is finished, same as operation *c* will not start until the operation *a2* and *b* finishes.

We can consider this priority as the operations priority, but in real cases we have more than one product, and the products may have different priorities and different levels (operation level in the tree). So the operation level will not be effective as the operation priority, example if we have two products the first product *A* in Fig. 1a and the second product *C* in Fig. 1b, and the priority for the product *A* is 1 and the priority for the product *C* is 2.

The scheduling algorithm will start with the operation that have the highest priority *a1* from the first product and *AA*, *BB* from the second product. After that it will start with the operation with the second highest priority *a2*, *b*, *d1* from the first product and *CC*, *BB* from the second product, and after that it will start with the third highest priority *c*, *d2* from

the first product and *DD* from the second product at this point the second product is finished before the first product despite that the first product have the highest priority and should be finished first. So the operation level could not be the operation priority, we can add to it the products priority (calculated using MCDM) to differentiate between the products based on the priority. When we add the product priority, the first product will be produced first. Therefore, we have two variables to set the production priority: products priority and the operations priority within the product operations tree (operations level). We will propose a new algorithm (Algorithm for Prioritization of Production Operations – APPO) for prioritizing the production operation in all products based on the calculated products priority and based on the operation level in each product.

Algorithm for Prioritization of Production Operations – APPO

The algorithm (APPO) will sort the production operations priority in all products, depending on products priority and on the operation level in the operations tree. We will calculate the operation level in each branch of the operations tree.

The algorithm steps:

- 1) Build operations trees for all products in the arrival orders, even if we have a duplicate products in the arrival orders, as shown in Fig. 2.
 - 2) Calculate the operations level (node) in each tree and we symbolize L_{ij} for the operation level, i is the number of product, and j is the operation number in the product. As shown in Fig. 1a, the operation level is the number of nodes from the current node to the root, and the root node gets the highest number. We calculate the operation level according to the steps: First, we count the operations in the longest branch in the tree and put the count value in the root. Second, we move down to the next operation level and deduct (1) at each level.
- Noting that the operation level is different between the operation *a1* and *b* because when we start with *b* before *a1*, the operation *b* has to wait until *a1* and *a2* to be processed, so *a1* should have the priority to be processed first.
- 3) Calculate the priority for all operations using this formula:

$$K = L_{ij} + P_i \times (L_{ij})^2. \quad (3)$$

We will call this formula (Operation Priority Formula), noting that K is the operation priority.

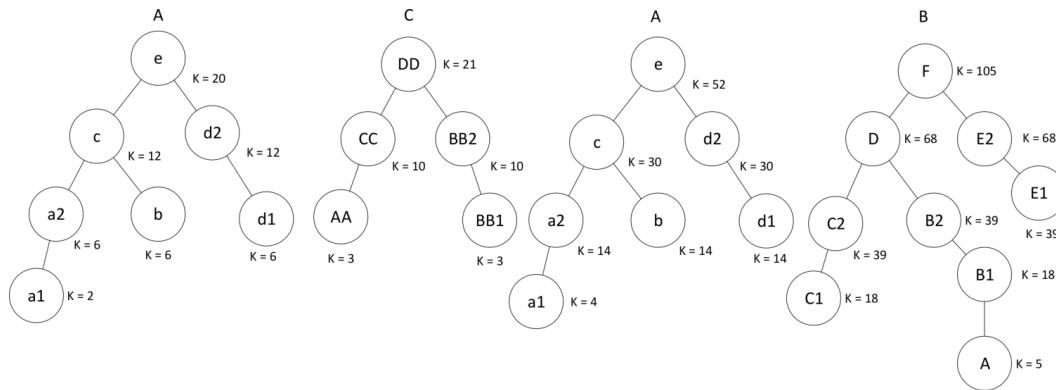

Fig. 2. Operations trees for the products A, C, A, B.

Table 6
The operation priority for the last operation for each product.

Products	Priority	Last operation	Operation priority formula	
			$K = L_{ij} + P_i$	$K = L_{ij} + P_i \times (L_{ij})^2$
A	1	e	5	20
C	2	DD	5	21
A	3	e	7	52
B	4	F	9	105

The operation with the lowest value K will have the highest priority; the operation priority formula consists of one main variable (K operation priority) and two constants (P_i Product Priority and L_{ij} operation level); these constants are fixed for each operation in each product, and the variable K changes from one operation to another.

For example, the priority for the operation b will be:

$$K = L_{ij} + P_i \times (L_{ij})^2 = 2 + 1 * 2^2 = 6.$$

The result of the algorithm is the priority for all products operations.

And all other operations priority calculated and shown in Fig. 2.

This operation priority equation has no mathematical basis, we came up with it experimentally. In order to the decision maker to choose the best formula, he needs to check the operation priority for the last operation in each product (the last operation is the root of the product operation tree).

To demonstrate this case of choosing the best formula we will present an example. Let's us start with the arrival orders in Table 1, the decision maker generates the products priority and calculates the operation levels for all products, he will put the first formula as:

$$K = L_{ij} + P_i. \tag{4}$$

And the second formula same as (3), and the priority will be shown in the Table 6.

The calculated operations priority for the first formula dose not differentiate between the first product A and the second product C . It means that the first and the second product will be produced together first, despite that the first product priority is higher than the second product. The second formula differentiate between the products based on its priority, the first product A with the higher priority will be produces first, and then the second product C .

Production scheduling

Scheduling is the process of creating a production schedule for a given set of jobs and resources. A production schedule specifies for each resource (machine) required for production, the planned start time and end time of each job assigned to that resource [50]. In other word, the production scheduling is a process of assigning tasks (operations) existed in the production plan to the machines based on priority, to generate the timetable. The timetable will be generated based on the production priority that is calculated from the previous steps, and through new proposed scheduling algorithm.

The production scheduling algorithm will scan the operation based on the priority from the highest to the lowest (in our case the lowest K value will have the highest priority), and generates the start and end time for each operation taking into consideration the operation precedence relationship.

Back to the Fig. 2, if the requested quantities from the first product is 100 and the second product is 90. First, we start with the operation that has the highest priority 2 like $a1$ and we produce all the requested quantities. Second, we start with the second highest priority 3 and produce all the requested quantities for the operations AA, BB in the second product. Third, we start with the third highest priority 4 and produce all the requested quantity for the operation $a1$ in the third product. When we reach the priority 20 and produce all the requested quantities for the operation e , at this point all the requested quantities from the first product are finished but not even one piece from the second product or any other product is finished. The problem is that we did not achieve our goal to produce multiple products at the same time.

In order to solve this problem, we need to produce a certain quantity from each operation less than the requested quantity and not all requested quantity in order to make a room for other product. We call this quantity “Economic Quantity”, and it aims to cover the setup time period by producing a several pieces and these several pieces processing time should be equal to or more than the setup time. It means that if a machine setup time is 10 minutes, we have to produce operations for 10 minutes or more, and not less than this setup time. We calculate the economic quantity using this formula:

$$q_{eco} \geq \frac{S_t}{t}. \quad (5)$$

Noting that S_t is the setup time, t is the processing time and q_{eco} is the economic quantity that we need to produce from each operation. At this point, the operations in other products will be produced together and multiple products will be produced at the same time.

The production scheduling algorithm will start with the operation that has the highest priority and produce the economic quantity, and continue to the lowest priority, at this point the requested quantity will not be finished so the algorithm will restart with all the priorities from the highest to the lowest until all the requested quantity are finished. After the algorithm is finished the timetable will be generated, and the products will be produced together at the same time. The scheduling algorithm pseudo-code is mentioned in the Appendix (online).

The Table 7 below shows an example about the generated timetable, noting that the Start Time and End Time in minutes. The first St operation is a setup operation for machine 1, and the first operation from the product A starts on the machine number 1 after the setup time operation, till the fourth oper-

ation. The second St operation is a setup operation for machine number 2, and the first operation from the product C starts on the machine number 2 after the second setup time operation. Noting that the q_{eco} for the operation 1 in the first product A is 4.

Table 7
Generated timetable.

Product	Count	Component num	Operation num	Machine num	Start time	End time
A	St	1	1	1	0	28
A	1	1	1	1	28	52
A	2	1	1	1	52	76
A	3	1	1	1	76	100
A	4	1	1	1	100	124
C	St	1	1	2	0	65
C	1	1	1	2	65	165
C	2	1	1	2	165	265

We can represent the production time model as follow:

Noting that B_{ab} the production time for the machine type a and the machine number b , St_{ij} the setup time for the operation j from the product i , q_{ij} the economic quantity for the operation j from the product i and p_{ij} the production time for the operation j from the product i .

The total production time for the Machine number “ $b = 1$ ” from the machine type “ $a = 1$ ” calculated as below:

$$B_{11} = St_{11} + q_{eco11} \times p_{11} \dots St_{ij} + q_{ecoij} \times p_{ij}, \quad (6)$$

$$B_{11} = \sum_{x=1}^n St_{ij} + \sum_{x=1}^n q_{ecoij} \times p_{ij}. \quad (7)$$

And other machines production time can be expressed as:

$$B_{11} = \sum_{x=1}^n St_{ij} + \sum_{x=1}^n q_{ecoij} \times p_{ij}, \quad (8)$$

$$\dots$$

$$B_{1b} = \sum_{x=1}^n St_{ij} + \sum_{x=1}^n q_{ecoij} \times p_{ij}, \quad (9)$$

$$B_{21} = \sum_{x=1}^n St_{ij} + \sum_{x=1}^n q_{ecoij} \times p_{ij}, \quad (10)$$

$$\dots$$

$$11B_{2b} = \sum_{x=1}^n St_{ij} + \sum_{x=1}^n q_{ecoij} \times p_{ij}, \quad (11)$$

$$\dots$$

$$B_{ab} = \sum_{x=1}^n St_{ij} + \sum_{x=1}^n q_{ecoij} \times p_{ij}. \quad (12)$$

In addition, the proposed method model is different from the serial (sequencing) production based

on the products priority that is calculated using the priority rules; The sequence production starts with the product with the highest priority and finishes all the ordered quantities, and starts with the product with the next high priority and finishes all the ordered quantities, and so on until all the products are finished.

The machines production time for the sequence production can be expressed as:
Noting that qu is the ordered quantity.

$$B_{ab} = St_{ij} + \sum_{x=1}^n qu_{ij} \times p_{ij}. \quad (13)$$

Comparison between the proposed method and the priority rules

We will compare the scheduling based on the proposed method (APPO) with the scheduling based on sequence production through some of the famous priority rules (FIFO, SPT, LPT, EDF, and Quantity). The comparison will be through the total production time (manufacturing time, makespan), the count of setup time operations, machine waiting time (idle time), the variety of produced products and the count of products produced weekly.

The Table 8 below represents the products priority based on each method for the orders in the Table 1.

Table 8
Priorities based on the proposed method and the priority rule.

Products	Ordered quantities	APPO	Priority rules				
			FIFO	SPT	LPT	EDF	Quantity
A	80	3	3	1	4	1	3
A	100	1	2	2	3	4	1
B	60	4	2	3	2	3	4
C	90	2	1	4	1	2	2

Figure 3 represents the result of the comparison between the scheduling based on the priority rules and based on the proposed method (APPO) through

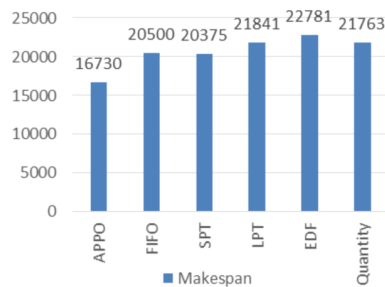

Fig. 3. Total production time for the proposed method and the priority rules.

the total production time that is represented in minutes. The result came from simulating the production for the ordered products based on the priority rule (FIFO, SPT, LPT, EDF, Quantity) and the proposed method and calculating the total processing time to each method (the maximum end time for operations).

It is found that the proposed method is better than the scheduling with the priority rules through the total production time. And the results of the comparison varies with different orders details.

Table 9 represent the result of comparing the scheduling based on the proposed method and the priority rules through the count of setup time operations.

Table 9
Setup time for the proposed method and the priority rule.

Products	APPO	Priority rules				
		FIFO	SPT	LPT	EDF	Quantity
A	40	21	21	21	21	21
A	47	21	21	21	21	21
B	45	25	25	25	25	25
C	70	15	15	15	15	15
Total	202	82	82	82	82	82

The proposed method has more setup time operations than the other methods due to the economic quantity.

Figure 4 represent the result of comparing the scheduling based on the proposed method and the priority rules through machine waiting time (idle time).

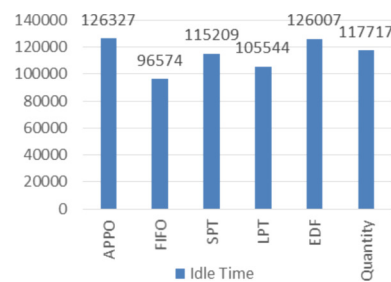

Fig. 4. Machine idle time for the proposed method and the priority rules.

The proposed method have the highest machine idle time, noting that the proposed method will fill the idle time in case we have products to process in this time.

Table 10 represent the count of products that will be produced each week, after scheduling the production for the orders in Table 1 based on the proposed method.

Table 10
The count of products produced each week for the method (APPO).

Products	Weeks					Total
	1	2	3	4	5	
A	15	30	15	20		80
A	30	15	15	30	10	100
B	12	12	24	12		60
C	12	6	6	12	54	90
Total	69	63	60	74	64	330
Variety	4	4	4	4	2	

Table 11 represents the count of products that will be produced each week, after scheduling the production for the orders in Table 1 based on the priority sorted using the (FIFO) priority rule.

Table 11
The count of products produced each week for the method (FIFO).

Products	Weeks							Total
	1	2	3	4	5	6	7	
A	0	0	0	0	0	23	57	80
A	0	0	0	100				100
B	0	0	0	0	0	60		60
C	0	0	17	73				90
Total	0	0	17	173	0	83	57	330
Variety	0	0	1	2	0	2	1	

Table 12 represents the count of products will be produced each week, after scheduling the production for the orders in Table 1 based on the priority sorted using the (SPT) priority rule.

Table 12
The count of products produced each week for the method (SPT).

Products	Weeks							Total
	1	2	3	4	5	6	7	
A	80							80
A	0	100						100
B	0	0	0	60				60
C	0	0	0	0	0	76	14	90
Total	80	100	0	60	0	76	17	330
Variety	1	1	0	1	0	1	1	

As Table 10, 11 and 12 shows, the proposed method produces more products each week, and provides a variety of products produced each week more than the (FIFO) and (SPT) priority rule, due to the scheduling based on the priority rules that start scheduling the product with the highest priority and then start with the second high priority until all products are scheduled.

Figure 5 represents the variety of products produced each week after scheduling the orders in Table 1 based on the priority sorted using the (FIFO) and (SPT) priority rule and based on the proposed method. The lines represents the variety of products produced each week, the first blue line represents the products produced through the proposed method, the second orange line represents the products produced through the priority rule (FIFO), the third green line represents the products produced through the priority rule (SPT). It is found that the proposed method provides a variety of products produced each week more than the (FIFO, SPT) priority rule.

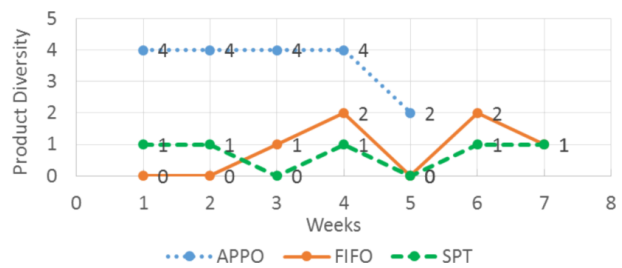

Fig. 5. Product diversity for scheduling based on (FIFO) and (SPT) priority rules and the proposed method.

The scheduling with the proposed method APPO achieves the goal of producing multiple different product at the same time, due to processing multiple operations from multiple products at the same time. Unlike the scheduling based on the priority rules that starts with the product that have the highest priority and then starts with the second high priority until all products are scheduled.

Operation priority formula

Back to the operation priority formula (3), in some cases, the proposed method is not better than the priority rules; in this case the decision maker can change the formula to suit the arrival order details and to get appropriate priorities. The decision maker will check the operation priority for the last operation in each product (the last operation is the root of the product operation tree) in Table 6 and check the weekly production for each product after scheduling with both formulas.

The Table 13 below represent the products, priority, the count of product produced and the production percentage for both formulas.

Consequently, the decision maker will check the Table 6 and 13 and choose the best formula. In our case, the second formula is the best. In addition, the decision maker can try another formulas.

Table 13
The count of product produced and the production percentage for both formulas.

Weeks	Products	Priority	$K = L_{ij} + P_i$		$K = L_{ij} + P_i \times (L_{ij})^2$	
			Produced quantity	Production percentage	Produced quantity	Production percentage
1	A	1	15	15%	30	30%
	C	2	12	13%	12	13%
	A	3	15	19%	15	19%
	B	4	0	0%	12	20%
2	A	1	30	45%	15	45%
	C	2	0	13%	6	20%
	A	3	28	54%	30	56%
	B	4	24	40%	12	40%
3	A	1	15	60%	15	60%
	C	2	12	27%	6	27%
	A	3	17	75%	15	75%
	B	4	12	60%	24	80%

...

Figure 6 below represents the result of the comparison between the scheduling based on the priority rules and based on the proposed method for the first and the second formula through the total production time that is represented in minutes.

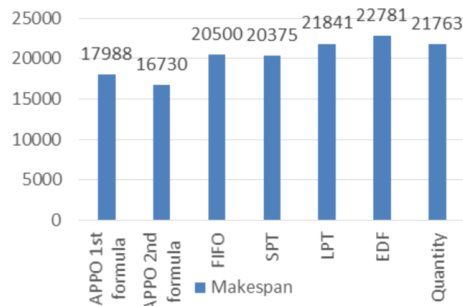

Fig. 6. The comparison result between the priority rules and the proposed method using the two formulas.

Conclusions

The study provided a method for production prioritization to produce multiple different products at the same time. This method prioritizes the products based on multiple variables using Multi Criteria Decision Making technique, and prioritizes the production operations using a new method, the method includes an algorithm called Algorithm for Prioritization of Production Operations (APPO). The algorithm depends on the products priority and operation level to calculate the operations priority. After that, the production was scheduled using the proposed scheduling algorithm based on the calculate operations priority using APPO algorithm and a timetable was generated. The Study provided a way to choose the suitable Operations Priority formula.

In addition, the study provided a comparison between the scheduling based on the proposed method and the scheduling based on the priority rules, through the total production time, the count of setup time operations, machine waiting time (idle time), the variety of produced products and the count of products produced weekly. The comparison concluded that the scheduling with the proposed method is better than the scheduling with the priority rules through the total production time, the proposed method has more setup time operations than the other methods due to the economic quantity, the proposed method has the highest machine idle time noting that the method will fill the idle time in case we have products to process in this time, the proposed method produce more products each week and provides a variety of products produced each week more than the priority rule.

The study concluded that the comparison result varies with different orders details, and the proposed method is better than the other methods by taking into consideration multiple variables together and decision maker preferences and sort the production priorities to produce multiple products at the same time, unlike the priority rules that depends on one variable.

References

- [1] Parnaby J., *Concept of a manufacturing system*, International Journal of Production Research, 17, 2, 123–135, 1979.
- [2] Baker K.R., *Introduction to sequencing and scheduling*, Handbook Oper. Res. Manag. Sci., 28, 203, 1974.

- [3] Liu S.Q., Ong H.L., *Metaheuristics for the mixed shop scheduling problem*, Asia-Pacific Journal of Operational Research, 21, 4, 97–115, 2004.
- [4] Graves C.S., *A review of production scheduling*, Operations Research, 29, 4, 646–675, 1981.
- [5] Robert A.W., Samit C., *Introduction to the scheduling problem*, IEEE Design & Test of Computers, 12, 2, 60–69, 1995.
- [6] Huang Y., Kanal L.N., Tripathi S.K., *Reactive scheduling for a single machine: problem definition, analysis, and heuristic solution*, International Journal of Computer Integrated Manufacturing, 3, 1, 6–12, 1990.
- [7] Brucker P., *Scheduling algorithms*, Springer Berlin Heidelberg New York, ISBN 978-3-540-20524-1, 4th ed., 2007.
- [8] Bera H., Gannon M.J., *Optimization techniques applied to job-shop scheduling*, IFAC Proceedings Volumes, 23, 3, 333–335, 1990.
- [9] Wojakowski P., Warzolek D., *The classification of scheduling problems under production uncertainty*, Research in Logistics & Production, 4, 3, 245–255, 2014.
- [10] Lei D., *Multi-objective production scheduling: a survey*, The International Journal of Advanced Manufacturing Technology, 43, 926, 2009.
- [11] Rodammer F.A., Wight K.P., *A recent survey of production scheduling*, IEEE Transactions on Systems, Man, and Cybernetics, 18, 6, 841–851, 1999.
- [12] Jones A., Rabelo L.C., *Survey of Job Shop Scheduling Techniques*, Wiley Encyclopedia of Electrical and Electronics Engineering, 1999, doi: 10.1002/047134608X.W3352.
- [13] Behnamian J., *Survey on fuzzy shop scheduling*, Fuzzy Optimization and Decision Making, 15, 3, 331–366, 2015.
- [14] Arisha A., Young P., Elbaradie M.A., *Job shop scheduling problem: an overview*, International Conference for Flexible Automation and Intelligent Manufacturing (FAIM 01), Dublin, Ireland, July 2001, 682–693, 2001, doi: 10.21427/D7WN5Q.
- [15] Mellor P., *A review of job shop scheduling*, Journal of the Operational Research Society, 17, 2, 161–171, 1966.
- [16] Sharma P., Jain A., *A review on job shop scheduling with setup times*, Journal of Engineering Manufacture, 2015, doi: 10.1177/0954405414560617.
- [17] Buxey G., *Production scheduling: Practice and theory*, European Journal of Operational Research, 36, 1, 17–31, 1989.
- [18] McKay K.N., Wiers V.C.S., *Unifying the theory and practice of production scheduling*, Journal of Manufacturing Systems, 18, 4, 241–255, 1999.
- [19] Chan F.T.S., Au K.C., Chan P.L.Y., *A decision support system for production scheduling in an ion plating cell*, Expert Systems with Applications, 30, 2006, 727–738, 2013.
- [20] Chen T., Zhou G., *Modeling production scheduling problem and its solution by genetic algorithm*, Journal of Computers, 8, 8, 2126–2133, 2013.
- [21] Chan F.T.S., Wong T.C., Chan L.Y., *Flexible job-shop scheduling problem under resource constraints*, International Journal of Production Research, 44, 11, 2071–2089, 2006.
- [22] Azzouz A., Ennigrou M., Said L.B., *A hybrid algorithm for flexible job-shop scheduling problem with setup times*, International Journal of Production Management and Engineering, 5, 1, 23–30, 2016.
- [23] Phanden R.K., Jain A., Verma R., *A genetic algorithm-based approach for job shop scheduling*, Journal of Manufacturing Technology Management, 23, 7, 937–946, 2012.
- [24] Ramazan S., *The new Fundamental Tree Algorithm for production scheduling of open pit mines*, European Journal of Operational Research, 177, 2, 1153–1166, 2007.
- [25] Akyol D.E., Bayhan G.M., *A review on evolution of production scheduling with neural networks*, Computers & Industrial Engineering, 53, 1, 95–122, 2007.
- [26] Bao L.W., Lu Y.Z., *Neural network based real-time production scheduling for industrial processes*, IFAC Proceedings Volumes, 22, 13, 85–90, 1989.
- [27] Lundgren G.M., Lundgren J.T., Persson J.A., *An optimization model for refinery production scheduling*, International Journal of Production Economics, 78, 3, 255–270, 2002.
- [28] Wang J., Luh P.B., Zhao X., Wang J., *An optimization-based algorithm for job shop scheduling*, Sadhana, 22, 2, 241–256, 1997.
- [29] Calleja G., Pastor R., *A dispatching algorithm for flexible job-shop scheduling with transfer batches: an industrial application*, Journal Production Planning & Control: The Management of Operations, 25, 4, 93–109, 2013.
- [30] Panwalkar S.S., Iskander W., *A survey of scheduling rules*, Operations Research, 25, 1, 45–61, 1977.
- [31] Haupt R., *A survey of priority rule-based scheduling*, Operations-Research-Spektrum, 11, 1, 3–16, 1989.

- [32] Holthaus O., Rajendran C., *Efficient dispatching rules for scheduling in a job shop*, International Journal of Production Economics, 48, 1, 87–105, 1997.
- [33] Sels S., Gheysen N., Vanhoucke M., *A comparison of priority rules for the job shop scheduling problem under different flow time- and tardiness-related objective functions*, International Journal of Production Research, 50, 15, 4255–4270, 2012.
- [34] Barman S., Lisboa J.V., *Cost performance of simple priority rule combinations*, Journal of Manufacturing Technology Management, 21, 5, 567–584, 2010.
- [35] Kawai T., Fujimoto Y., *An efficient combination of dispatch rules for job-shop scheduling problem*, IN-DIN '05, 2005 3rd IEEE International Conference on Industrial Informatics, 2005.
- [36] Koruca H.I., Aydemir E., *A priority rule based production scheduling module on faborg-sim simulation tool*, Gazi University Journal of Science, 27, 4, 1143–1155, 2014.
- [37] Iringova M., Vazan P., Kotianova J., Jurovata D., *The comparison of selected priority rules in flexible manufacturing system*, Proceedings of the World Congress on Engineering and Computer Science, 2, WCECS 2012, 2012.
- [38] Triantaphyllou E., Shu B., Sanchez S.N., Ray T., *Multi-criteria decision making: an operations research approach*, Encyclopedia of Electrical and Electronics Engineering, 15, 1998, 75–186, 1998.
- [39] Linkov I., Satterstrom F.K., Tkachuk A., Seager T.P., *A multi-criteria decision analysis approach for prioritization of performance metrics*, Managing Critical Infrastructure Risks, Springer 2007, 261–298, 2007.
- [40] Kolios A., Mytilinou V., Minguez E.L., Salonitis K., *A comparative study of multiple-criteria decision-making methods under stochastic inputs*, Energies, 2016, 9, 566, 2016.
- [41] Pamucar D., Bozanic D., Randjelovic A., *Multi-criteria decision making: An example of sensitivity analysis*, Serbian Journal of Management, 12, 1, 1–27, 2017.
- [42] Kumar K.K., Nagaraju D., Gayathri S., Narayanan S., *Evaluation and selection of best priority sequencing rule in job shop scheduling using hybrid MCDM technique*, Frontiers in Automobile and Mechanical Engineering, IOP Conf. Series: Materials Science and Engineering, 197, 2017, 012059, 2017.
- [43] Leoneti A.B., *Consideration regarding the choice of ranking multiple criteria decision making methods*, Pesquisa Operacional, 36, 2, 259–277, 2016.
- [44] Podvezko A., Podvezko V., *Influence of data transformation on multicriteria evaluation result*, Procedia Engineering, 122, 2015, 151–157, 2015.
- [45] Wang Y., Liu D., Ruhe G., *Formal description of the cognitive process of decision making*, IEEE Transactions on Systems, Man, and Cybernetics (C), 36, 2, 124–133, 2004.
- [46] Niyazi M., Tavakkoli-Moghaddam R., *Solving a facility location problem by three multi-criteria decision making methods*, International Journal of Research in Industrial Engineering, 3, 4, 41–56, 2014.
- [47] Dodgson J., Spackman M., Pearman A., Phillips L., *Multi-criteria analysis: a manual*, Department for Communities and Local Government: London, (Chapter 5), 30–45, 2009.
- [48] Podvezko V., *Application of AHP technique*, Journal of Business Economics and Management, 10, 2, 181–189, 2009.
- [49] Yoon K.P., Hwang C.L., *Multiple attribute decision making: an introduction*, SAGE Publications, Inc; 1 edition, 1995.
- [50] Vieira G.E., Herrmann J.W., Lin E., *Rescheduling manufacturing systems: a framework of strategies, policies, and methods*, Journal of Scheduling, 6, 1, 39–62, 2008.

Production Scheduling Algorithm

The algorithm uses such internal variables: “*i*” is the products, “*j*” is the operations, “*K*” is the operation Priority, “*st*” is the setup time, “*qeco*” is the operation economic quantity, “*Stime*” is the operation start time, “*Etime*” is the operation end time, “*Duration*” is the operation duration, “*Pree_duration*” is the operation precedence duration, “*Prod_Quantity*” is the produced quantity for each operation, “*Machine*” is the machine that process *j* operation from *i* product, “*Sequence*” is the operation priority sequence and “*pree*” is the operation precedence.

Below is the pseudo-code for the algorithm with comments presented:

Step.1: Defining the variables values: the count of products $c = \text{Count}(\text{Products})$, the count of operations $u = \text{Count}(\text{Operation})$, $st = 0$, $qeco = 0$, $Stime = 0$, $Etime = 0$, $Duration = 0$, $Pree_duration = 0$, $Prod_Quantity = 0$.

Step.2: Defining a table *T* that contains data about products, operations, machines “*Machines*”, operation precedence (*pree*) “*Pree*”, operation priority, operation priority sequence “*Sequence*”, ordered quantity “*Quantity*” and produced quantity “*Produced_Quantity*”.

Table $T = [i, j, \text{Machine}, \text{Pree}, k, \text{Sequence}, \text{Quantity}, \text{Produced_Quantity}]$;

Step.3: Filling the Data Table with values:

This step has the below functions: *Get_Machine*(*i,j*) to get the machine number for the operation “*j*” from the product “*i*”, *Get_Operation_Procedence*(*i,j*) to get the precedence for the operation “*j*” from the product “*i*”, *Get_Operation_Priority*(*i,j*) get the operation priority for the operation “*j*” from the product “*i*” and *Add_new_row*(*n, m, Machine, Pree, k, Sequence, Quantity, 0*) for adding a new row in the data table.

```

Sequence = 1;
for ( n = 1 ; n <= c ; n++ )
{
  for ( m = 1 ; m <= u ; m++ )
  {
    Machine = Get_Machine(i,j);
    pree = Get_Operation_Procedence(i,j);
    K = Get_Operation_Priority(i,j);
    T = Add_new_row(n, m, Machine, Pree, k,
Sequence, Quantity, 0);
    Sequence = Sequence + 1;
  }
}

```

Step.4: Filling the Sequence variable in the data table *T* based on the operation priority *K*:

The sequence is a number represents the operation priority, we set this sequence because we may have two or more operation with same operation priority and we use this number as an *ID* in the data table *T*.

```

for ( w = 0 ; w < K.Count ; w++ )
{
  for ( sort = 0 ; sort < K.Count ; sort++ )
  {
    if ( K[sort] > K[sort + 1] )
    {
      temp = Sequence[sort + 1];
      Sequence[sort + 1] = Sequence[sort];
      Sequence[sort] = temp;
    }
    elseif ( K[sort] = K[sort + 1] )
    {
      if ( pree = "null" )
      { }
      else
      {
        Pree_Count_1 = Get_Pree_Count[sort];
        Pree_Count_2 = Get_Pree_Count[sort + 1];
        if ( Pree_Count_1 > Pree_Count_2 )
        { }
        else
        {
          temp = Sequence[sort + 1];
          Sequence[sort + 1] = Sequence[sort];
          Sequence[sort] = temp;
        }
      }
    }
  }
}

```

Step.5: Generating the timetable based on operation priority (Sequence):

This step has the below functions: *Get_Operation_Priority*(*Sequence*(*y*)) get the operation priority for the operation “*j*” from the product “*i*” based on the sequence number “*Sequence*(*y*)”; *Get_Product* (*Sequence*(*y*)), *Get_Component* (*Sequence*(*y*)), *Get_Operation* (*Sequence*(*y*)) and *Get_Machine* (*Sequence*(*y*)) to get products, components, operations and machines based on the sequence number; *Get_Operation_Procedence* (*Sequence*(*y*)) to get the operation precedence based on sequence number; *Calculate_economic_quantity* (*Sequence*(*y*)) to calculate the economic quantity for the operation based on the sequence number; *Get_Operation_setuptime* (*Sequence*(*y*)) to get the operation setup time based on sequence number; the *Get_Machine_end_Time* (*Sequence* (*y*)) to get the end time for a machine that process a certain operation based on the sequence number; *Write* (*Product, "St", Component, Operation, Machine, Stime, Etime*) to write the timetable rows and each row represent operation setup time details or operation processing details; *Get_Produced_Quantity* (*Sequence*(*y*)) to get the produced quantity from a certain operation based on the sequence number; the *Update_row* (*y, Prod_Quantity*) to update the produced quantity in the data table *T* based on the sequence number “*y*”.

```

for (qu = 0; qu < Total_Production_Quantity; qu++)
{
  for (y = 1 ; y < Sequence.Count ; y++)
  {
    while (Quantity != Produced_Quantity)
    {
      K = Get_Operation_Priority(Sequence(y));
      Product = Get_Product(Sequence(y));
      Component = Get_Component(Sequence(y));
      Operation = Get_Operation(Sequence(y));
      Machine = Get_Machine(Sequence(y));
      pree = Get_Operation_Procedence(Sequence(y));
      qeco =
Calculate_economic_quantity(Sequence(y));
      if ( pree = "null" )
      { // Setup Time Data:
        Duration =
Get_Operation_setuptime(Sequence(y));
        if ( Machine is idle )
        { Stime = 0; }
        else
        {
          Stime = Get_Machine_end_Time(Sequence(y));
        }
        Etime = Stime + Duration;
        Write (Product, "St", Component, Operation,
Machine, Stime, Etime);
        Duration = 0, Stime = 0, Etime = 0;
        // Processing Operation Data:
        for ( x = 0; x< qeco; x++ )
        {
          Duration =
Get_Operation_Processing_Time(Sequence(y));
          Stime =
Get_Operation_setuptime(Sequence(y));
          Etime = Stime + Duration;
          Write (Product, x + 1, Component, Operation,
Machine, Stime, Etime);
        }
        Prod_Quantity =
Get_Produced_Quantity(Sequence(y));
        Prod_Quantity = Prod_Quantity + qeco;
        T = Update_row(y, Prod_Quantity);
      }
      else
      {
        if (the Operation have one Pree task)
        { // Setup Time Data:
          Duration =
Get_Operation_setuptime(Sequence(y));
          Pree_duration =
Get_Pree_Duration_Time(Sequence(y));
          Stime = Pree_duration;
          Etime = Stime + Duration;
          Write (Product, "St", Component, Operation,
Machine, Stime, Etime);

```

```

Duration = 0, Stime = 0, Etime = 0;
// Processing Operation Data:
for ( x = 0; x< qeco; x++ )
{
  Duration =
Get_Operation_Processing_Time(Sequence(y));
  Stime =
Get_Operation_setuptime(Sequence(y));
  Etime = Stime + Duration;
  Write (Product, x + 1, Component, Operation,
Machine, Stime, Etime);
}
  Prod_Quantity =
Get_Produced_Quantity(Sequence(y));
  Prod_Quantity = Prod_Quantity + qeco;
  T = Update_row(y, Prod_Quantity);
}
else
{ // Setup Time Data:
  Duration =
Get_Operation_setuptime(Sequence(y));
  Pree_duration =
Get_Max_Pree_Duration_Time(Sequence(y));
  Stime = Pree_duration;
  Etime = Stime + Duration;
  Write (Product, "St", Component, Operation,
Machine, Stime, Etime);
  Duration = 0, Stime = 0, Etime = 0;
  // Processing Operation Data:
  for ( x = 0; x< qeco; x++ )
  {
    Duration =
Get_Operation_Processing_Time(Sequence(y));
    Stime =
Get_Operation_setuptime(Sequence(y));
    Etime = Stime + Duration;
    Write (Product, x + 1, Component, Operation,
Machine, Stime, Etime);
  }
  Prod_Quantity =
Get_Produced_Quantity(Sequence(y));
  Prod_Quantity = Prod_Quantity + qeco;
  T = Update_row(y, Prod_Quantity);
}}}}

```