

EFFECT OF TYPE AND PROPORTION OF DIFFERENT
STRUCTURE-CREATING ADDITIONS ON THE INACTIVATION
RATE OF PATHOGENIC BACTERIA IN SEWAGE SLUDGE
COMPOSTING IN A CYBERNETIC BIOREACTOR

AGNIESZKA WOLNA-MARUWKA¹, JACEK DACH²

¹ The Life Sciences University of Poznań, Department of Agricultural Microbiology
ul. Szydlowska 50, 60-656 Poznań, Poland
e-mail: amaruwka@up.poznan.pl

² The Life Sciences University of Poznań, Institute of Agricultural Engineering
ul. Wojska Polskiego 50, 60-625 Poznań, Poland
e-mail: jdach@up.poznan.pl

Keywords: Pathogenic microorganisms, sewage sludge, compost, bioreactor.

Abstract: The paper contains a microbiological characteristic of sewage sludge composted in controlled conditions together with bio-wastes (straw, sawdust, bark). An experiment was carried out in which the composted material was mixed up in adequate weight proportion and placed in bioreactor chambers with a constant air flow. The composting process aimed at defining the development dynamics and the survival of pathogenic microorganisms in the sewage sludge composted with different additions in a cybernetic bioreactor. Samples of compost necessary for microbiological analyses were taken at the same time, in reference to the actual temperature value. Bacteriological studies were carried out on selected substrates by plate method determining the number of pathogenic bacteria from the species: *Salmonella*, *Clostridium perfringens*, as well as from *Enterobacteriaceae* family. In the experiments, the presence of living eggs of intestinal ATT pathogens was determined by floatation method, as well. It was found that the sewage sludge used in composting process did not contain any *Salmonella* spp. bacteria or any living eggs of intestinal ATT pathogens. Composting process completely eliminated the number of bacteria from *Enterobacteriaceae* family, but it did not contribute to the elimination of *Clostridium perfringens* bacteria. On the basis of the obtained results, it was found that the elimination of the studied groups of microorganisms, in all studied composts took place with the increase of temperature. In the case of *Enterobacteriaceae*, it was found that their complete removal from the composted material took place in chamber K3, while in the remaining chambers, it followed 48 hours later. Elimination of the vegetative forms of *Clostridium perfringens* bacteria followed after 96 hours of composting, in all composts at the same time. The obtained composts met the sanitary norms according to the regulations of the EC Commission No. 185/2007 of February 20, 2007 which changed the regulation of WE No. 809/2003 and WE No. 810/2003 referring to the extension of the validity period of transitional means for composting plants and biogas producing plants according to the instruction of WE No. 1774/2002 of European Parliament and Council and according to the instruction of the Minister for Agriculture and Country Development (2004).

INTRODUCTION

It is commonly known that sewage sludge can constitute the place where pathogenic microorganisms, not only bacteria, but also living eggs of intestinal parasites, mainly *Ascaris* spp., *Trichuris* spp., *Toxocara* spp., can exist and survive [2, 5, 7, 12, 13, 18, 27]. These microorganisms can be a threat for both humans and animals, particularly when sewage sludges are utilized in agriculture without a previous sanitary control. Recently,

there appear an increasing number of sewage treatment plants where sewage sludges are purified. So far, sewage used to be stored.

Sewage sludges contain a great amount of organic substances, therefore, it may seem that their agricultural utilization is most justified, particularly that our soils do not possess any abundant amounts of organic matter. Sewage sludge could become an alternative source of natural fertilizers. However, such utilization requires that some conditions must be fulfilled before it can be realized. Sewage sludges cannot contain excessive harmful amounts of heavy metals and they have to be safe from the sanitary point of view [6, 10]. The dose of sewage sludge must be safe for the environment and for the health of humans and animals. In order to fulfill the required conditions, the following technologies can be applied: liming, chlorination, thermal drying, pasteurization, or composting. The last procedure by the composting process seems to be the most friendly method for the natural environment. This method is not only simple and easy, but it is also expensive. Composting is a process of natural decomposition of organic substance with the help of microorganisms which act during that process. Therefore, an adequate C:N proportion (25:30), the proper oxygenation and humidity of the compost mass must be obtained during the composting process, frequently a structure-developing material is added to the sludge. This material may consist of straw, saw-dust, bark, leaves, etc. [8]. The structure-creating material decreases the concentration of heavy metals and pathogenic microorganisms, too [19]. In result of a correct composting process, mature compost is obtained which has a brown or black color, a loose consistency and, what is most important; it cannot constitute any sanitary-epidemiological threat. Pathogenic microorganisms are reduced during the composting process. Such compost is the most suitable for agricultural fertilization because it supplies a very valuable mineral and organic fertilizer.

The objective of the studies was the determination of the development dynamics and the survival of pathogenic microorganisms depending on the type of the structure-creating additives (straw, sawdust, disintegrated and not disintegrated bark) composted together with the sewage sludge in a cybernetic bioreactor.

MATERIAL AND METHODS

Experiments were carried out in laboratory conditions in 2007, in four bioreactors of 125 dm³ capacity and equipped with electronic sensors for constant recording of some process parameters (temperature, concentration of carbon dioxide, methane, ammonia and oxygen) (Fig. 1). The experiments were conducted with a constant air flow amounting to 4 dm³·min⁻¹ in all chambers. Materials for studies were thoroughly mixed in a container in weight proportion in relation to dry matter. The microbiological and chemical analyses of initial materials are presented in Tables 1 and 2.

Material in bioreactors was composted for 672 hrs, while compost samples were taken from all chambers at the same time depending on the actual temperature of the composted material. On microbiological selective media, using plate method, the number of colony forming units (cfu) of *Salmonella* genus bacteria, *Clostridium perfringens* and bacteria from *Enterobacteriaceae* family were determined. *Salmonella* spp. was determined on XLT medium of Merck after 18–24 hours at 37°C [9]. Selection of substrate designed for the isolation of the above mentioned bacteria resulted from its chemical composition: 1.6 g·dm⁻³ pepton proteose No. 3, 3.0 g·dm⁻³ yeast extract, 5.0 g·dm⁻³ L-lysine,

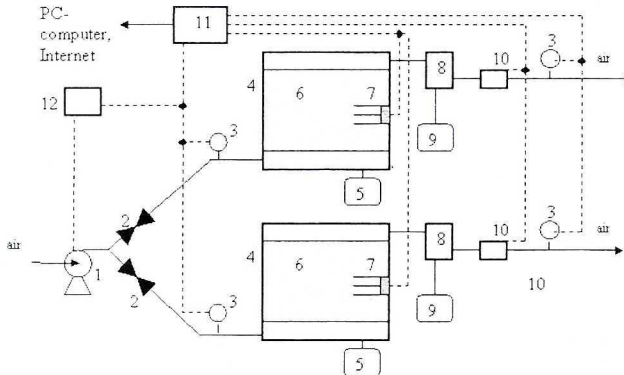

Fig. 1. Schematic diagram of the two-chamber bioreactor

1 – pump, 2 – flow regulator, 3 – flow meter, 4 – isolated chamber, 5 – drained liquids container, 6 – composted mass, 7 – sensors set, 8 – air cooling system, 9 – condensates container, 10 – column of gases content analysis (NH_3 , O_2 , CO_2 , CH_4 , SH_2), 11 – 16-channel recorder, 12 – air pump steering system

Table 1. The number of microorganisms [$\text{cfu}\cdot\text{g}^{-1}\cdot\text{d.m}$] and helminth eggs [$\text{piece}\cdot\text{kg}^{-1}\cdot\text{d.m}$.] in biowastes used in experiment

Initial material	<i>Salmonella</i> spp.		<i>Enterobacteriaceae</i>		<i>Clostridium perfringens</i>	
	cfu	SD*	cfu	SD*	cfu	SD*
Sewage sludge	0.00	0.00	$29.33 \cdot 10^5$	1.23	$0.18 \cdot 10^5$	0.06
Straw	0.00	0.00	$0.27 \cdot 10^5$	0.06	$12.11 \cdot 10^5$	4.91
Sawdust	0.00	0.00	0.00	0.00	0.00	0.00
Bark	0.00	0.00	$2.32 \cdot 10^5$	0.04	0.00	0.00
Initial material	<i>Ascaris</i> ssp.		<i>Trichuris</i> ssp.		<i>Toxocara</i> ssp.	
	piece·kg ⁻¹ d.m.	SD*	piece·kg ⁻¹ d.m.	SD*	piece·kg ⁻¹ d.m.	SD*
Sewage sludge	0.00	0.00	0.00	0.00	0.00	0.00

* – standard deviation

Table 2. The characteristics of biowastes in composts

Chamber	Components	Dry mass	Contents [%]	C/N initial	C/N final
K1	sewage sludge	16.7	45	16.40	10.56
	bark	32.7	50		
	straw	86.0	5		
K2	sewage sludge	16.7	45	16.60	13.20
	bark	32.7	35		
	sawdust	96.0	15		
	straw	86.0	5		
K3	sewage sludge	16.7	45	17.01	14.17
	bark	32.7	15		
	sawdust	96.0	35		
	straw	86.0	5		
K4	sewage sludge	16.7	45	17.10	14.01
	sawdust	94.0	50		
	straw	86.0	5		

3.75 g·dm⁻³ xylose, 7.5 g·dm⁻³ lactose, 7.5 g·dm⁻³ saccharose, 0.8 g·dm⁻³ ammonium gel citrate(III), 6.8 g·dm⁻³ sodium thiosulphate(VI), 5.0 g·dm⁻³ NaCl, 0.08 g·dm⁻³ phenol red, 18.0 g·dm⁻³ agar. Confirmative and taxonomy tests for *Salmonella* genus were carried out according to the Polish Standard PN-Z-19000-1 [23]. In order to determine the number of bacteria from *Enterobacteriaceae* family, the selective substratum of Merck (Chromocult® Coliform Agar) was used. The above mentioned substrate consisted of: 3.0 g·dm⁻³ peptone, 5.0 g·dm⁻³ NaCl, 2.2 g·dm⁻³ sodium dihydrogen phosphate, 2.7 g·dm⁻³ sodium monohydrogen phosphate, 1.0 g·dm⁻³ sodium pyruvate, 1.0 g·dm⁻³ tryptophane, 10.0 g·dm⁻³ agar, 1.0 g·dm⁻³ sorbitol, 0.15 g·dm⁻³ tergitol®7, 0.2 g·dm⁻³ chromogenic mixture. Plates were incubated at 37°C for 24 hours [21]. *Clostridium perfringens* was determined on TSC agar substratum with triptose, sulphate and cycloserine by incubation of plates in a thermostat with 22% of CO₂ content, at 37°C for 24 hours [16]. Typical *C. perfringens* colonies were characterized by black color. In order to identify the kinds belonging to *Enterobacteriaceae*, the oxidase tests (Oxidase Test Sticks, Liofilchem firm) and the biochemical tests (EnetroPluri-Test, Liofilchem firm) were used. In addition, eggs of *Ascaris* spp., *Trichuris* spp. and *Toxocara* spp. parasites were isolated from the experimental sewage sludge using the floatation method [15].

Statistical analyses were applied in the experiment which included the calculation of the mean number of microorganisms in the given compost and the terms of analyses. Standard deviations and LSDs were calculated by the Statistica 8.0 program.

RESULTS AND DISCUSSION

The analysis of changes in the number of bacteria from *Enterobacteriaceae* family in the experiment (Tab. 4) indicated that next to temperature (Fig. 2), other factors exerting an influence on growth dynamics as well as on the survival of the discussed bacteria included most probably the type of the bio-wastes in the mass subjected to composting and their proportional share.

Enterobacteriaceae family includes genera being important for human health and for the hygiene of consumption products: *Salmonella*, *Shigella*, *Escherichia*, *Serratia*, *Proteus* etc. In majority, they are represented by mesophilic bacteria of medium size

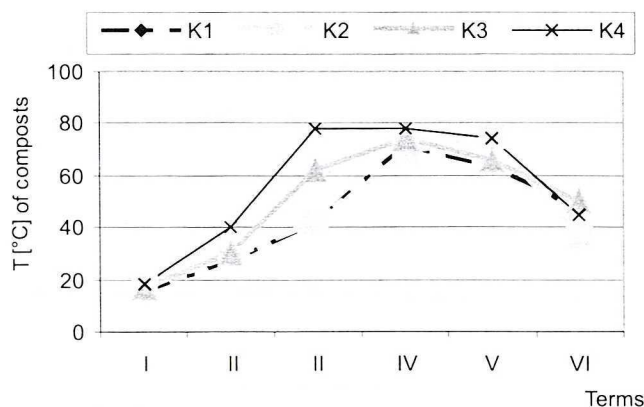

Fig. 2. The changes of temperature in biowastes during composting process

Table 4. The number of *Enterobacteriaceae* in composts [$\cdot 10^3$ cfu \cdot g $^{-1}$ d.m. of material]

Kind of compost	Temperature of compost [°C]	$\cdot 10^3$ cfu \cdot g $^{-1}$ d.m. of compost	Standard deviation
I date – beginning of experiment			
K1	15	2500.00	255.26
K2	18	3058.80	483.02
K3	17	1661.50	241.47
K4	18	1239.90	422.92
LSD _{0.05} = 768.46		LSD _{0.01} = 1006.32	
II date – after 24 h			
K1	27	17647.20	1056.52
K2	28	21293.10	547.51
K3	30	6.20	3.00
K4	40	79840.90	13056.16
LSD _{0.05} = 13765.79		LSD _{0.01} = 18026.63	
III date – after 48 h			
K1	42	21855.10	4656.35
K2	42	34252.20	3160.76
K3	62	0.00	0.00
K4	78	69123.70	32327.97
LSD _{0.05} = 34636.13		LSD _{0.01} = 45356.84	
IV date – after 72 h			
K1	71	860.50	71.96
K2	69	62.40	2.54
K3	74	0.00	0.00
K4	78	0.30	0.21
LSD _{0.05} = 75.79		LSD _{0.01} = 99.25	
V date – after 96 h			
K1	64	0.00	0.00
K2	75	0.00	0.00
K3	66	0.00	0.00
K4	74	0.00	0.00
VI date – after 672 h			
K1	47	0.00	0.00
K2	36	0.00	0.00
K3	50	0.00	0.00
K4	45	0.00	0.00

which do not create any spores. In order to identify the species of the above mentioned family isolated from the composted materials on the day of experiment, biochemical tests were carried out. In the case of each combination, 18 bacterial colonies were subjected to biochemical analyses. It was found that the species composition of the discussed bacteria in the compost was very similar (Tab. 3), furthermore, the most frequently isolated bacterium was the *Enterobacter agglomerans* species.

Table 3. Species composition of *Enterobacteriaceae* family in material subjected to composting in the first term (initial material)

K1	K2	K3	K4
<i>Escherichia fergusonii</i>	<i>Escherichia fergusonii</i>	<i>Escherichia fergusonii</i>	<i>Escherichia fergusonii</i>
<i>Proteus penneri</i>	<i>Proteus penneri</i>	<i>Citrobacter youngae</i>	<i>Proteus penneri</i>
<i>Citrobacter youngae</i>	<i>Citrobacter youngae</i>	<i>Proteus mirabilis</i>	<i>Citrobacter youngae</i>
<i>Proteus mirabilis</i>	<i>Proteus mirabilis</i>	<i>Citrobacter freundii</i>	<i>Proteus mirabilis</i>
<i>Citrobacter freundii</i>	<i>Citrobacter freundii</i>	<i>Enterobacter</i>	<i>Enterobacter</i>
<i>Enterobacter</i>	<i>Enterobacter</i>	<i>agglomerans</i>	<i>agglomerans</i>
<i>agglomerans</i>	<i>agglomerans</i>	<i>Providencia rettgeri</i>	<i>Providencia rettgeri</i>
<i>Providencia rettgeri</i>	<i>Providencia rettgeri</i>	<i>Yersinia aldovae</i>	<i>Yersinia aldovae</i>
<i>Yersinia aldovae</i>	<i>Yersinia aldovae</i>	<i>Proteus rettgeri</i>	<i>Klebsiella ozaenae</i>
<i>Klebsiella ozaenae</i>	<i>Klebsiella ozaenae</i>	<i>Escherichia coli</i>	<i>Proteus rettgeri</i>
<i>Proteus rettgeri</i>	<i>Proteus rettgeri</i>	<i>Pantoea agglomerans</i>	
<i>Escherichia coli</i>	<i>Escherichia coli</i>	<i>Serratia marcescens</i>	
	<i>Pantoea agglomerans</i>		
	<i>Serratia marcescens</i>		

On the basis of the results of microbiological analyses presented in Table 4, it was found that in term I, the significant number of *Enterobacteriaceae* was detected in the material subjected to the composting process in the chamber K2 (sewage sludge – 45%, not disintegrated bark – 35%, sawdust – 15%, straw – 5%). The lowest number of *Enterobacteriaceae* was in chamber K4 (sludge – 345%, sawdust – 50%, straw – 5%). An analysis of the share of the particular biowastes in the compost masses (Tab. 2) allows to presume that the reason of the greater number of the discussed bacteria in the composted material in the chambers K1–3 in relation to the chamber K4 was the addition of disintegrated bark, which was not added to the compost mass in the chamber K4. The 24-hour composting process (term II) contributed to the increase of temperature in the chambers, on the average, by 10–22°C, and to a violent proliferation of bacteria in the composts K1, K2 and K4. The above phenomenon was most probably connected with the presence of organic substance easily decomposable by microorganisms which provide to bacteria a source of food and structural material. A successive factor insuring an optimal growth of these mesophilic microorganisms could be the temperature dominating in the chambers in the term III.

The above observations confirm the studies carried out by Błaszczuk and Fit [1]. Also in the studies of Budzińska and Michalska [3], an increase of the number of *Escherichia coli* (belonging to *Enterobacteriaceae* family) in the initial stage of the composting process was observed. Zaremba [28] argued that an optimal temperature for the growth of *Escherichia coli* bacteria was 37°C and a very good development of bacteria could be also obtained within the temperature range from 10 to 45°C. According to the above mentioned author, the optimal pH for bacteria development should be 7.2 to 7.4 and this has been confirmed also in our studies (Fig. 3).

However, some controversies in term II refer to the violent decrease of the number of *Enterobacteriaceae* in compost K3, where T, pH or C:N proportion showed values similar to the remaining composts. It can be only supposed that the applied proportional share of the particular biowastes contributed to the strong development of the saprophytic microflora of the composted material because it showed antagonistic properties in relation to the family of the discussed bacteria. It could have been also caused by the

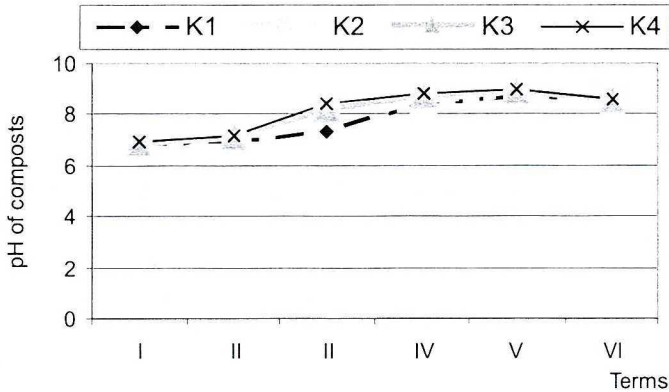

Fig. 3. The changes of pH in biowastes during composting process

presence of some organic contaminants (e.g. dioxins, polycyclic aromatic carbohydrates, pesticides etc.) in the given batch of sewage sludges.

In the successive term of analyses (term III), the temperature value increased in all chambers, particularly in K3 and K4, where a decreased proliferation of bacteria cells was recorded and even their complete destruction was found (chamber K3). Further temperature increase in the composted materials, in the successive terms of studies, contributed to complete hygienization of the composts. From the obtained study results, one can conclude that the thermophilic conditions were the factors responsible for the limitation and the determination of bacteria development. The above observations confirm the study results obtained by Budzińska and Michalska [3], and by Pionek [22]. Also, according to the opinion of Szejniuk and Kluczek [24], temperature is the deciding factor exerting an influence on the survival of pathogens in the composting process. According to Epstein [11], a complete reduction of *Escherichia coli* takes place at the temperature of 60°C already after the lapse of one hour, and the reduction period is shortened when the temperature is higher. In our own studies, a complete reduction of *Enterobacteriaceae* was reached at 62°C in compost K3 (45% sludge + 15% of not disintegrated bark + 35% of sawdust + 5% of straw) already after the lapse of 2 days from experiment set-up. The analysis of study results revealed the occurrence of negative correlations between the number of bacteria and the values of temperature, and even pH (Figs 4–7).

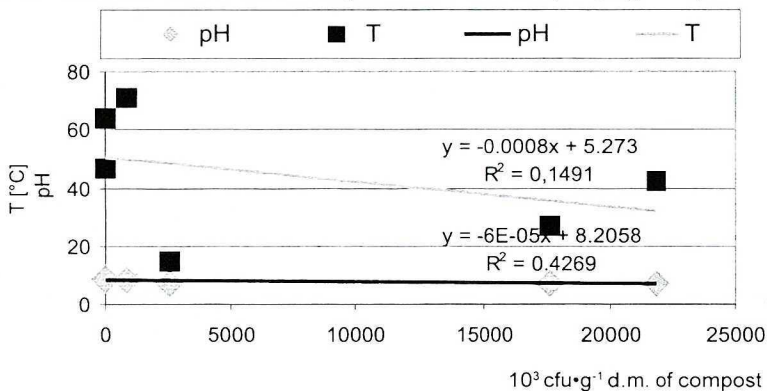

Fig. 4. Relation between the number of *Enterobacteriaceae* and the value of temperature and pH in K1 compost

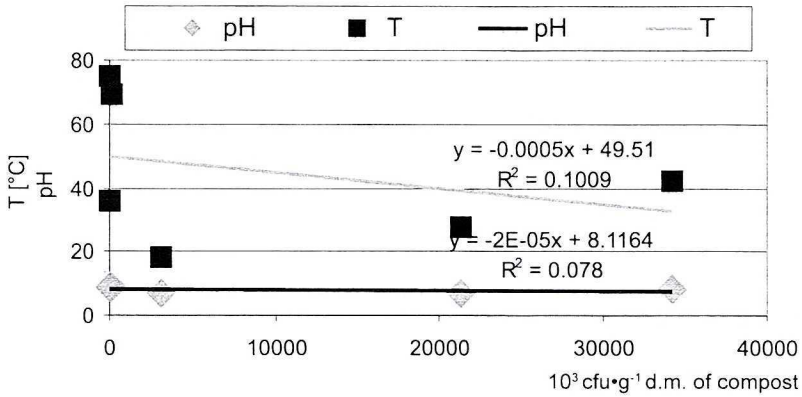

Fig. 5. Relation between the number of *Enterobacteriaceae* and the value of temperature and pH in K2 compost

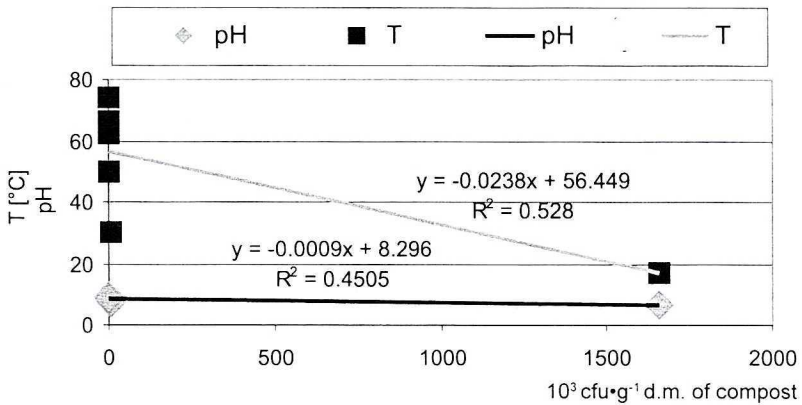

Fig. 6. Relation between the number of *Enterobacteriaceae* and the value of temperature and pH in K3 compost

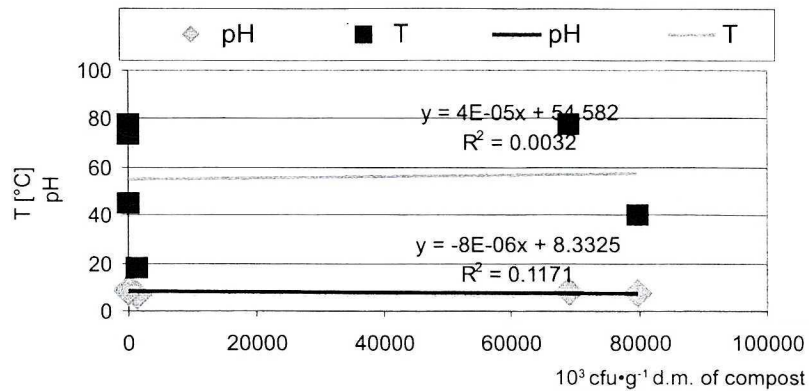

Fig. 7. Relation between the number of *Enterobacteriaceae* and the value of temperature and pH in K4 compost

Similarly as in the case of *Enterobacteriaceae*, both the composition of the composted material and the term of analysis exerted an influence on the proliferation of *Clostridium perfringens* bacteria (Tab. 5) *Clostridium perfringens* bacteria very often appear in natural compost. These spore-forming, anaerobic bacteria are also an indicator confirming water contamination with human faces.

Table 5. The number of *Clostridium perfringens* in composts [$\cdot 10^3$ cfu \cdot g $^{-1}$ d.m. of material]

Kind of compost	Temperature of compost [°C]	$\cdot 10^3$ cfu \cdot g $^{-1}$ d.m. of compost	Standard deviation
I date – beginning of experiment			
K1	15	20.00	4.40
K2	18	49.50	8.20
K3	17	5.20	2.50
K4	18	5.40	2.30
LSD _{0.05} = 10.39		LSD _{0.01} = 13.62	
II date – after 24 h			
K1	27	20.10	6.10
K2	28	45.40	11.20
K3	30	17.20	9.00
K4	40	17.60	7.70
LSD _{0.05} = 18.27		LSD _{0.01} = 23.93	
III date – after 48 h			
K1	42	8.20	4.40
K2	42	24.60	15.20
K3	62	76.80	10.30
K4	78	33.90	2.70
LSD _{0.05} = 20.02		LSD _{0.01} = 26.22	
IV date – after 72 h			
K1	71	6.50	2.80
K2	69	0.60	0.50
K3	74	15.40	19.00
K4	78	3.40	1.80
LSD _{0.05} = 20.30		LSD _{0.01} = 26.59	
V date – after 96 h			
K1	64	0.00	0.00
K2	75	0.00	0.00
K3	66	0.00	0.00
K4	74	0.00	0.00
VI date – after 672 h			
K1	47	25241.20	11111.10
K2	36	14947.70	7927.20
K3	50	268051.00	57637.90
K4	45	119352.10	81714.80
LSD _{0.05} = 105970.60		LSD _{0.01} = 138771.10	

Development dynamics of *Clostridium perfringens* bacteria in the composting process showed a different course than that of bacteria from *Enterobacteriaceae* family. Our own studies indicated (Tab. 5) that in the initial stage of the composting process, together with temperature increase, the number of those bacteria also increased in all composts (term II). The strongest proliferation of the discussed cells was at that time observed in chambers K3 and K4. This phenomenon was certainly connected with the optimal conditions for the development of bacteria dominating in the composted masses. Optimal temperature for *Clostridium perfringens* is 37°C, but these bacteria develop within 18–38°C and their optimal pH value is 7.0–7.5 [28]. After 48 hours of the composting process (term II), a decrease of the microorganisms number was observed in chambers K1 and K2. In chambers K3 and K4, in spite of a high temperature (62 and 78°C), the number of bacteria continued to increase. According to Błaszczuk and Fit [1], the chemical composition and pH of the medium exerted a high effect on the growth and development of microorganisms. The analysis of study results revealed the occurrence of positive correlations between the number of *Clostridium perfringens* and the values of temperature and pH (Figs 8–11).

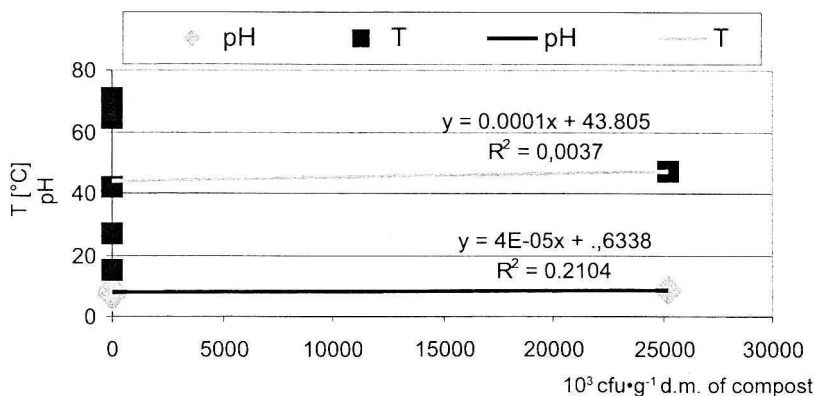

Fig. 8. Relation between the number of *Clostridium perfringens* and the value of temperature and pH in K1 compost

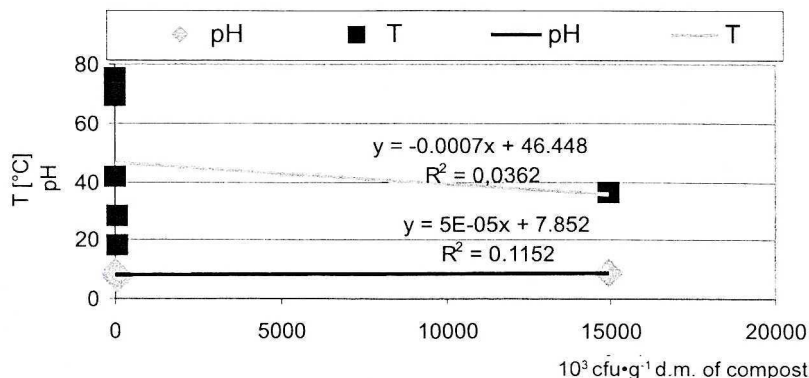

Fig. 9. Relation between the number of *Clostridium perfringens* and the value of temperature and pH in K1 compost

creases below 50°C, the number of *Clostridium perfringens* increases again. This is also confirmed by the studies of Burtscher *et al.* [4] and Lasaridi *et al.* [20]. In the studies of the above mentioned authors, a repeat growth development of bacteria was noted in the final phase of the composting process. According to Gbolagade [14], composting is not only and merely an oxygenation process, therefore, anaerobic microorganisms are not completely eliminated during the process.

On the basis of microbiological analyses, it was found that the number of *Clostridium perfringens* bacteria was not eliminated in the experiment. High temperature caused a complete elimination of the vegetative forms in both experiments, however, after the ending of the thermophilic conditions, there followed a repeat growth development of the vegetative bacteria from the spore forming phase. Thus, the composting process does not lead to the elimination of *Clostridium perfringens*. On the basis of statistical analysis, it was shown that the negative correlation between the number of bacteria and the values of temperature appeared only in K2 and K4 composts (Figs 9 and 11). In our experiment, components used in the composting process were also microbiologically analyzed with the purpose of detecting bacteria from *Salmonella* spp. Microbiological analysis of the sewage sludge and of the structure creating materials (straw, saw-dust, and bark) indicated that the sludge was free of any bacteria from this genus (Tab. 1). Also from the composts in both experiments, none of the discussed pathogenic bacteria was isolated. This effect is satisfactory since the smallest number of bacteria from *Salmonella* spp. genus would disqualify the sludge as a fertilizer for agricultural use [6, 10]. Microscopic analysis of the sewage sludge did not show any presence of pathogenic intestinal ATT eggs either. Therefore, the sludge can be used for agricultural purposes because it meets the sanitary standards according to the instruction of the Minister of Agriculture and Country Development of 2004. This instruction permits to utilize sludge as fertilizer, when among others, the number of living eggs of intestinal ATT pathogens in one kilogram of the studied sludge equals zero.

CONCLUSIONS

1. In the analyzed sewage sludge, no *Salmonella* spp. bacteria or any eggs of intestinal ATT pathogens were found.
2. The number of *Enterobacteriaceae* in 1g of sewage sludge used in the experiment was greater than 1000 cfu, therefore, the sewage sludge did not meet the sanitary norms required for their use in agriculture.
3. In the case of all components, it was found that the composting process completely eliminated *Enterobacteriaceae* bacteria. This phenomenon appeared at the shortest rate in compost K3 (45% sewage sludge + 15% not disintegrated bark + 35% saw-dust + 5% straw), where after the lapse of 2 days, at 62°C, there took place a complete elimination of the discussed bacteria.
4. It was also found that the composting process did not contribute to the elimination of *Clostridium perfringens* in any of the applied combinations. Furthermore, the dynamics analyzing of the studied bacteria during the experimental course, did not show that any effects of the bio-wastes proportion used in the composting was exerted on the rate of bacteria inactivation.
5. The developed composts can be agriculturally utilized, because they meet the sanitary

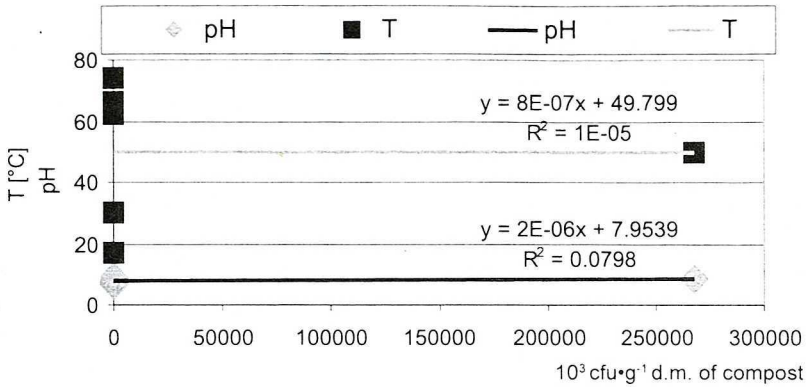

Fig. 10. Relation between the number of *Clostridium perfringens* and the value of temperature and pH in K1 compost

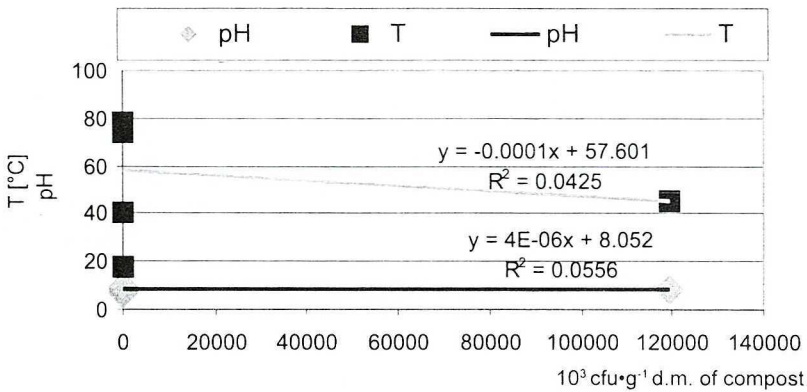

Fig. 11. Relation between the number of *Clostridium perfringens* and the value of temperature and pH in K1 compost

In the further part of the experiment (term IV), high temperature showed to be a factor limiting the number of *Clostridium perfringens* bacteria number. In that term (IV), it was found that temperature increase to 69–78°C in the analyzed composts contributed to the elimination of *Clostridium perfringens* bacteria. The greatest elimination of the discussed bacteria number was at the time when the temperature was 69°C in compost K2 with $24.60 \cdot 10^3 \text{ cfu} \cdot \text{g}^{-1} \text{ d.m.}$ to $0.6 \cdot 10^3 \text{ cfu} \cdot \text{g}^{-1} \text{ d.m.}$ High temperature maintained during the successive day caused a complete elimination of *Clostridium perfringens* in all chambers. Also Juteau *et al.* [18], during their studies carried out in bioreactors showed that temperature of 60°C eliminates vegetative forms of *Clostridium*. Also, according to Wieland and Sawicka [26], temperature increase to 50–60°C causes complete elimination of vegetative forms of *Clostridium* only. However, in term VI, after 672 hours, there followed a repeated development of bacteria in the mesophilic phase of the composting process. The reason of this phenomenon most probably was the development of *Clostridium perfringens* vegetative forms from the spore forming stage resistant to high temperature, since endospores do not get destroyed in the thermophilic phase. Therefore, with the lapse of time, in the successive stages of composting, when the temperature de-

norms required by the Instruction of the Minister of Agriculture and Country Development referring to organic fertilizers (2004) and according to the Instruction of WE Commission No. 185/2007 of February 2, 2007.

Acknowledgements

The study was supported by MNiSzW grants no. 2 PO6 005 29.

REFERENCES

- [1] Błaszczyk M., M. Fit: *Succession of microorganisms during composting of organic wastes*, [in:] Materials from the VII Scientific-Technical Conference Biological process of solid organic, September 8–9, 2008, Zielona Góra, pp. 1–5 (in Polish).
- [2] Boulter J.I., J.T. Trevors, G.J. Boland: *Microbial studies of compost: bacterial identification, and their potential for turfgrass pathogen suppression*, World Journal Microbiology and Biotechnology, **18**(7), 661–671 (2007).
- [3] Budzińska K., M. Michalska: *Survival of E. coli 0157 in the composting process of sewage sludges*, [in:] Materials from the VII Scientific Native Conference, August 1–3, 2005, Koszalin, pp. 1–12 (in Polish).
- [4] Burtscher C., P.A. Fall, O. Christ, P.A. Wilderer, S. Wuertz: *Detection and survival of pathogens during two-stage thermophilic/mesophilic anaerobic treatment of suspended organic waste*, Water Science and Technology, **38**(12), 123–126 (1998).
- [5] Capizzi-Banas S., M. Deloge, M. Remy, J. Schwartzbrod: *Liming as an advanced treatment for sludge sanitisation: helminth eggs elimination – Ascaris eggs as model*, Water Research, **38**(14-15), 3251–3258 (2004).
- [6] Commission Regulation (EC) No 185/2007 of 20 February 2007 amending Regulations (EC) No 809/2003 and (EC) No 810/2003 as regards extension of the validity of the transitional measures for composting and biogas plants under Regulation (EC) No 1774/2002 of the European Parliament and of the Council.
- [7] Czekala J., J. Dach, A. Wolna-Maruwka: *Use of bioreactor in model studies of sewage sludges composting*, Water, Environmental, Country Area, **6**(2), 29–40 (2006) (in Polish).
- [8] Dach J., J. Jędrus, M. Adamski, I. Kowalik, Z. Zbytek: *Bioreactor for studies on organic materials decomposition processes*, Journal of Research and Applications in Agricultural Engineering, **48**, 4–9 (2003) (in Polish).
- [9] Dusch H., M. Altwegg: *Evaluation of five new planting media for isolation of Salmonella species*, Journal of Clinical Microbiology, **33**(4), 801–804 (1995).
- [10] Directive of the Minister of Agriculture and Rural Development 04.236.2369, 2004 (in Polish).
- [11] Epstein E.: *The Science of Composting*, Technomic Publishing Comp. Inc, 87–106, Pennsylvania USA, 1997.
- [12] Garcia-Orenes F., A. Roldan, C. Guerrero, J. Mataix-Solera, J. Navarro-Pedreno, I. Gomez, J. Mataix-Beneyto: *Effect of irrigation on the survival of total coliforms in three semiarid soils after amendment with sewage sludge*, Waste Management, **27**(12), 1815–1819 (2007).
- [13] Gauthier F., A. Archibald: *The ecology of “fecal indicator” bacteria commonly found in Pulp and paper mill water system*, Water Research, **35**(9), 2207–2218 (2001).
- [14] Gbolagade J.S.: *Bacteria associated with compost used for cultivation of Nigerian edible mushrooms Pleurotus tuber-regium (Fr.) Singer. and Lentinus squarrosulus (Berk.)*, African Journal of Biotechnology, **5**(4), 338–342 (2006).
- [15] Gundlach J.L., A.B. Sadzikowski, K. Tomczuk: *Contamination with Toxocora sp. eggs in selected urban and rural environments*, Veterinary Medicine, **52**(6), 395–396 (1996) (in Polish).
- [16] Hauschild A.H.W., R. Hilsheimer: *Evaluation and modifications of media for enumeration of Clostridium perfringens*, Applied Microbiology, **27**, 78–82 (1974).
- [17] Jahannessen G.S., Ch.E. James, H.E. Allison, D.L. Smith, J.R. Saunders, A.J. McCarthy: *Survival of Shiga toxin-encoding bacteriophage in a compost model*, FEMS Microbiology Letters, **245**(2), 369–375 (2005).
- [18] Juteau P., D. Tremblay, O. Cheikh-Baye, J.G. Bisailon, R. Beaudet: *Swine waste treatment by self-heating aerobic thermophilic bioreactors*, Water Research, **38**, 539–546 (2004).
- [19] Krzywy E., A. Izewska, C. Wołoszyk: *Estimation of chemical composition and fertilization value of sewage sludges and composts produced of communal sewage sludge*, Advances of Agricultural Sciences Problem Issues, **499**, 165–171 (2004) (in Polish).

- [20] Lasaridi K., I. Protopapa, M. Kotsou, G. Pilidish, T. Maniosc, A. Kyriacou: *Quality assessment of composts in the Greek market: The need for standards and quality assurance*, Journal of Environmental Management, 80, 58–65 (2006).
- [21] Manafi M., W. Kneifel: *A combined chromogenic-fluorogenic medium for simultaneous detection of total coliforms and E. coli in water*, Zentralbl. Hyg., 225–234 (1989).
- [22] Pionek M.: *The effect of sewage sludge composting on the quantitative state of some groups of bacteria and fungi*, Acta Microbiologica Polonica, 29(1), 83–90 (2000).
- [23] Polish Standard Committee, Polish Standard PN-Z-19000-1: *Evaluation of the sanitary soil condition, Identification of bacteria of Salmonella genus*, 2001 (in Polish).
- [24] Szejniuk B., J.P. Kluczek: *Survival of Escherichia coli of faeces type and fecal Streptococcus in composts from communal sludges*, Sciences Issues AU in Wrocław, 13 (293), 77–83 (1996) (in Polish).
- [25] Singh R.P., M. Agrawal: *Potential benefits and risks of land application of sewage sludge*, Waste Management, 28(2), 347–358 (2008).
- [26] Wieland E., A. Sawicka: *Microbiological transformations in sewage sludge in the SDE system*, Municipal Review, 12(11), 53–56 (2000) (in Polish).
- [27] Wolna-Maruwka A., J. Czekala, J. Dach: *Dynamics of microorganisms changes in sewage sludges composted with straw*, Advances Agricultural Sciences Problem Issues, 506, 531–540 (2005) (in Polish).
- [28] Zaremba M.L., J. Borowski: *Bases of medical microbiology*, Medical Publisher PZW, Warszawa 1994 (in Polish).

Received: February 10, 2009; accepted: May 5, 2009.

WPLYW RODZAJU ORAZ UDZIAŁU PROCENTOWEGO RÓŻNYCH DODATKÓW STRUKTURÓTWÓRCZYCH NA TEMPO INAKTYWACJI BAKTERII CHOROBTWÓRCZYCH W OSADACH ŚCIEKOWYCH KOMPOSTOWANYCH W CYBERNETYCZNYM BIOREAKTORZE

Praca przedstawia charakterystykę mikrobiologiczną osadu ściekowego kompostowanego w warunkach kontrolowanych wraz z bioodpadami (słoma, trociny, kora). Przeprowadzono doświadczenie, w którym wymieszano materiał w odpowiednim stosunku wagowym a następnie umieszczono w komorach bioreaktora o stałym przepływie powietrza. Przeprowadzony proces kompostowania miał na celu określenie dynamiki rozwoju oraz przeżywalności drobnoustrojów chorobotwórczych w osadzie ściekowym kompostowanym z różnymi dodatkami w cybernetycznym bioreaktorze. Próbkę kompostu niezbędne do przeprowadzenia analiz mikrobiologicznych pobierano w tym samym czasie, w odniesieniu do aktualnej wartości temperaturowej. Badania bakteriologiczne przeprowadzono na wybiórczych podłożach metodą płytkową oznaczając liczebność bakterii chorobotwórczych z rodzaju *Salmonella*, *Clostridium perfringens*, jak również z rodziny *Enterobacteriaceae*. W doświadczeniach oznaczano również metodą flotacyjną obecność żywych jaj pasożytów jelitowych ATT. Wykazano, że osad ściekowy poddawany kompostowaniu nie zawierał bakterii *Salmonella* spp. oraz żywych jaj pasożytów jelitowych ATT. Proces kompostowania całkowicie wyeliminowała bakterie z rodziny *Enterobacteriaceae*, natomiast nie przyczynił się do usunięcia bakterii *Clostridium perfringens*. Na podstawie uzyskanych wyników badań stwierdzono, że eliminacja badanych grup mikroorganizmów we wszystkich kompostach następowała wraz ze wzrostem temperatury. W przypadku *Enterobacteriaceae* stwierdzono, że całkowite ich usunięcie z kompostowanego materiału najszybciej wystąpiło w komorze K3, a w pozostałych komorach 48 h później. Eliminacja form wegetatywnych bakterii *Clostridium perfringens* wystąpiła po 96 h godzinach kompostowania we wszystkich kompostach jednocześnie. Uzyskane komposty spełniały normy sanitarne zgodne z Przepisem Komisji (EC) Nr 185/2007 z 20 lutego 2007 r. zmieniające rozporządzenia (WE) nr 809/2003 oraz (WE) nr 810/2003 w zakresie przedłużenia okresu obowiązywania środków przejściowych dla kompostowni i wytwórni biogazu na mocy rozporządzenia (WE) nr 1774/2002 Parlamentu Europejskiego i Rady oraz zgodne z Rozporządzeniem Ministra Rolnictwa i Rozwoju Wsi (2004).