

Microprocessor-based photometric light intensity sensor for airport lamps quality testing

Kacper Podbucki^{a*}, Jakub Suder^a, Tomasz Marciniak^a, Wojciech Mańczak^b, Adam Dąbrowski^a

^a Division of Signal Processing and Electronic Systems, Institute of Automatic Control and Robotics, Poznan University of Technology, 5 M. Skłodowska-Curie Sq., 60-965 Poznań, Poland

^b Faculty of Computing and Telecommunications, Poznan University of Technology, 5 M. Skłodowska-Curie Sq., 60-965 Poznań, Poland

Article info

Article history:

Received 22 Jun. 2022

Received in revised form 08 Aug. 2022

Accepted 16 Oct. 2022

Available on-line 26 Oct. 2022

Keywords:

Photodiode; lighting measurement; in-pavement airport lamps; microprocessor system; optoelectronic sensors.

Abstract

The paper presents a design and performance analysis of a photosensor device enabling the measurement of the visible light illuminance. The sensor is designed for use in the light metering matrix of a mobile measurement platform allowing the correct operation of in-pavement airport lamps. This kind of control can be required by regulations and must meet the standards defined by the European Union Aviation Safety Agency (EASA). An important assumption of the solution was to obtain the highest possible speed of a measurement acquisition so that the control process would take place in a relatively short time. The proposed module concept is dedicated to the task of testing the quality of airport lamps, due to the characteristics of the photosensitive elements matching the light beams emitted by luminaries. The device is based on a VTP1220FBH photodiode and an ATmega328P microcontroller, which, in addition to the analogue-to-digital conversion and correction, sends the results back to the master unit via the I²C bus.

1. Introduction

Airports are required to carry out a number of inspections of infrastructure located at airports [1]. They concern, *inter alia*, lighting systems, including lamps built into the surface of the runway and taxiways. Due to the large area of the airport and the number of lamps installed, daily inspection is a time-consuming task. In the case of air operations, in addition to the aspect related to safety, time is also extremely important. Any delay or occupation of the runway, even for maintenance purposes, entails high costs for airports. Therefore, many efforts are made to carry out all works as quickly as possible while maintaining safety and quality standards.

Until recently, the control of lamps installed in airport areas for some instrument landing system (ILS) categories did not require the use of a specialized equipment. In most cases, the inspection was carried out visually, but, nowadays, regulations require the use of reliable devices. In addition, the preparation of a manual test report takes

more time than in the case of using a system that allows for automatic control and lamp quality report during the inspection. For automated testing of airport lamp lighting quality, automatic measuring systems can be used, for example, a measuring car trailer [2]. A general scheme of such a mobile inspection system for runway or taxiway in-pavement lamps is shown in Fig. 1.

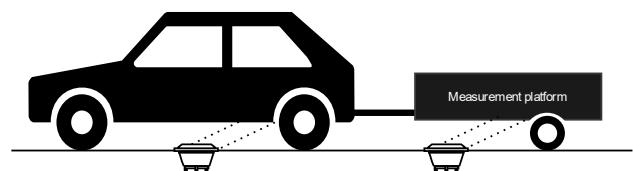

Fig. 1. Idea of airport lamps quality testing with a measuring platform.

The measuring platform for testing the quality of performance of airport lamps is equipped with light-intensity sensors, mounted under the chassis in the form of a matrix [3]. Their task is to measure the value of the incident light intensity from the main beam of the tested

*Corresponding author at: kacper.podbucki@put.poznan.pl

lamp. The measurement takes place while the matrix passes over the in-pavement lamps. Due to the use of prisms in the lamps which make them shine the main beam at a small angle of maximum 9 degrees vertically, the matrix is mounted low above the surface. Lamps are installed at different distances from each other depending on their purpose and type [4]. The distance between consecutive lamps is from 7.5 to 15 m on the taxiway and up to 30 m on the runway [5]. However, at the point where the taxiway and runway centre lines meet, lamps of different types may be only 60 cm apart. Such a close location of the light sources causes the risk of disturbances in the measurement of the main beam intensity with the beam of the neighbouring lamp. To avoid this, the measurement platform is equipped with a cover which limits the area under the chassis in which the matrix is illuminated by the lamp to the length of the platform, which is approx. 1 m.

Such limitations require a relatively high operating speed of the light-intensity sensors in the measurement matrix. Data acquisition must take place at a speed that allows for a measurement while the platform is moving over the tested lamp. Time when the luminaire is in the darkroom under the device is short and depends on the speed of the measurement set. It is important to make several series of measurements within this time interval to be able to determine the maximum value of the luminous intensity of the main lamp beam. The aim of this paper is to analyse commercial light-intensity sensors and to implement the authors' sensor with a photosensitive element in the form of a photodiode.

2. Light intensity sensor modules

There are light-intensity sensors available on the market, however, due to their characteristics, two types of commercial devices were selected for testing.

The GY-302 module is a board with an integrated BH1750 sensor, a suitable voltage stabilizer with capacitors and pull-up resistors for the I²C line [6,7]. The GY-302 module is a very popular solution and is used in different applications, e.g., for the control of runway edge lamps with a drone [8,9] and automotive system solutions [10].

The sensor works with a supply voltage in the range of 3–5 V, has a resolution of 16 bits (working range from 1 to 65535 lx). Communication takes place via the I²C bus and due to the ADDR pin, it is possible to change the address from 0x23 to 0x5C after giving a high or low state. The sensor offers a light-intensity measurement in lux units with the following accuracy: 1 lx in H-resolution mode (120 ms between consecutive measurements) or 4 lx in L-resolution mode (16 ms between consecutive measurements). Despite the good quality parameters of the measurements, a drawback of this solution is the low speed of data acquisition. The tests presented in Ref. 3 showed that in the case of the BH1750 module, correct light-intensity readings were possible for a maximum frequency of 20 Hz. At a higher frequency, there were already changes consisting of missing all zero readings between successive flashes of the light source. In such a situation, it is usually possible to recognize the lamp and the area between, since a decrease in value is visible.

The Grove Light Sensor v1.2 module is built of an LS06-S photoresistor and an operational amplifier LM358

in a voltage follower configuration [11]. The supply voltage is also in the range from 3 to 5 V. However, this sensor, unlike the BH1750, returns the measurement as an analogue value, not representing the exact value of the light intensity (it describes the relative light intensity in the range from 0 to 11000 lx). The main difference compared to GY-302 is a necessity to process the output value by an analogue-to-digital converter.

As part of the laboratory tests, experiments were carried out on the measurement accuracy of each of the sensors. Figures 2 and 3 show the voltage output signal for a 100 Hz and 1000 Hz square pulse-width modulation (PWM) light input signal for the Grove Light Sensor v1.2. It can be observed that for higher frequencies (e.g., 1000 Hz), a proper measurement of particular lamps is impossible. More information about the platform speed and PWM response is included in the next section.

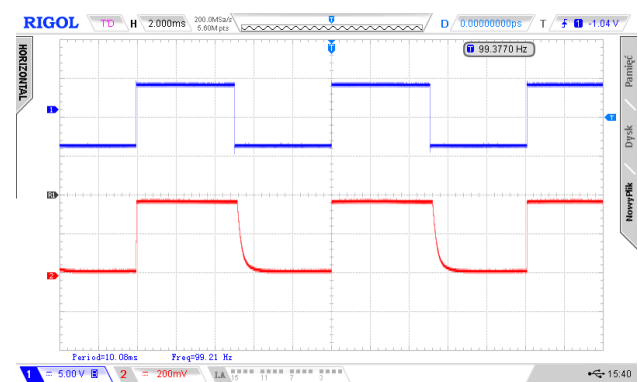

Fig. 2. Grove Light Sensor v1.2 voltage output signal for a 100 Hz square PWM signal.



Fig. 3. Grove Light Sensor v1.2 voltage output signal for a 1000 Hz square PWM signal.

Airports are required to carry out a number of inspections of the infrastructure located at airports [1]. They concern, *inter alia*, lighting systems including lamps built into the surface of the runway and taxiways. Due to the large area of the airport and the number of lamps installed, the daily inspection is a time-consuming task. In the case of air operations, in addition to the aspect related to safety, time is also extremely important. Any delay or occupation of the runway, even for maintenance purposes, entails high costs for airports. Therefore, many efforts are made to carry out all works as quickly as possible while maintaining safety and quality standards.

The next stage of testing was to test the saturation of the measurement when illuminated with an IDM 4671 in-pavement airport lamp. The tests were carried out using a stand built to automatically measure the intensity of light. This laboratory equipment, presented in Fig. 4, allows for the measurement of the multipoint luminous intensity characteristics of an airport lamp, depending on the horizontal angle and vertical position of the sensor relative to the lamp prism.

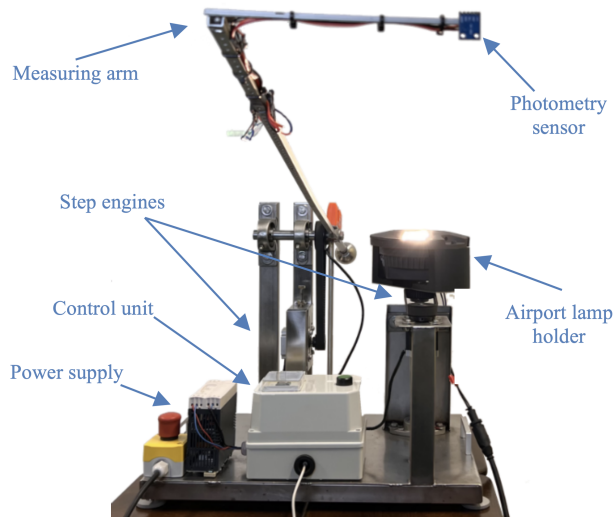

Fig. 4. Laboratory measurement equipment for airport in-pavement lamps quality testing.

Sensors were mounted on a movable arm at a distance of 1 m from the light source, the IDM4671 lamp. The test consisted of setting each of the sensors at the point of incidence of the main beam and slowly increasing the voltage (and, thus, the current), which increased the intensity of the lamp illumination. The maximum values of light intensity read by the sensors were compared to the value of the intensity of the current supplied as a power supply to the lamp, which translates into the saturation value of the main light beam (Table 1).

Table 1

Maximum ranges of light intensity measurement by sensors measured at a distance of 1 m.

| Sensor | GY-302 | Grove Light Sensor v1.2 |
|--------------------------------|--------|-------------------------|
| Airport lamp current [A] | 4.17 | 3.45 |
| Airport lamp saturation [%] | 10 | 3 |
| Measured light intensity [klx] | 65.536 | 11.093 |

In Ref. 3, in which the Authors used the BH1750 measurement module, it was shown that the theoretical maximum speed of the measurement platform is approximately 4.5 km/h. This speed is relatively low, and it will take about 30 min to explore a runway with a length of more than 2 km. Therefore, it seems important to eliminate the influence of acquisition limits with the BH1750 and to construct a sensor using a photodiode allowing to obtain higher measurement speeds.

3. Photodiode for measuring light intensity of airport lamps

Airport lamps are characterized by a specific light spectrum, depending on the airport area. The characteristics of the lamps were tested in Ref. 2 and it is possible to notice that, depending on the type of lamp, their maximum point of light intensity is in the wavelength range from 550 to 680 nm.

After analysing commercially available photodiodes and taking into account the wavelength, for example, the maximum sensitivity point and the application of the V_λ correction, two photodiodes were selected that best met the assumptions. These are the key values to obtain reliable measurement values for the brightness of airport lamps.

The BPW21 photodiode has a wavelength range of λ_d from 350 to 820 nm [12, 13]. The point of maximum sensitivity is a wavelength of 550 nm (Fig. 5). The viewing angle is 55 degrees and the photosensitive area is 7.45 mm². The photodiode has a turn-on and turn-off time of 1.5 μ s. The dark current value is 2 nA. The photodiode is closed in a hermetic housing, and its popular applications are exposure meter for daylight and artificial light with high colour temperature in photographic fields and colour analysis.

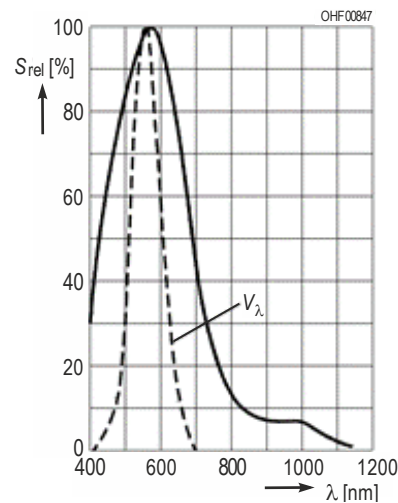

Fig. 5. BPW21 relative spectral sensitivity [12].

The VTP1220FBH photodiode has a point of maximum sensitivity for a wavelength of 550 nm [14] and allows operation in the wavelength range λ_d from 400 to 700 nm (Fig. 6). The viewing angle is 70 degrees, and the photosensitive area is 1.219 mm². The dark current value is

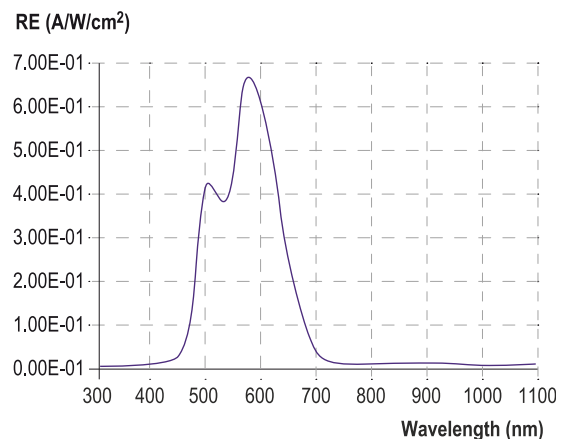

Fig. 6. VTP1220FBH spectral sensitivity [14].

10 nA. The photodiode has an IR filtre and its main applications are streetlight switching, contrast control, colorimeters, and camera exposure control.

Assuming the conditions as in Ref. 3, the estimated speeds of the measuring platform are summarized in Table 2.

Table 2

Estimated platform speeds assuming 4 measurements at a distance of 20 cm.

| Speed of the platform [km/h] | Speed of the platform [m/s] | Required sampling rate [sample/s] |
|------------------------------|-----------------------------|-----------------------------------|
| 10 | 2.78 | 55.56 |
| 20 | 5.56 | 111.11 |
| 30 | 8.33 | 166.67 |
| 40 | 11.11 | 222.22 |
| 50 | 13.89 | 577.78 |
| 60 | 16.67 | 333.33 |

For the above-mentioned photodiodes, an initial test was carried out consisting of a forcing process observation by means of an LED connected to a signal functional generator. The diode was connected to a current-voltage converter system built based on an LM358 operational amplifier. The signal from the function generator and the output from the amplifier with a photodiode were connected to a RIGOL MSO2202A oscilloscope. Thanks to this, it was possible to observe the difference between the forcing signal and the signal at the output of the system.

The tests consist of generating a PWM signal with a 50% duty cycle and observing the output signal from the measuring system. The gradual increase of the frequency of the PWM signal led to changes in the shape of the output waveform, and the rise and fall times of the diode current above a certain frequency would not allow for correct measurements to be taken.

For the BPW21 photodiode, the rise and fall times are 1.5 μ s according to the catalogue note. When illuminated at a frequency up to 1 kHz (Fig. 7), the circuit correctly reproduced the signal wave, although it was possible to notice delays at the falling edge. For frequencies above 5 kHz, the signal lost its square-wave shape.

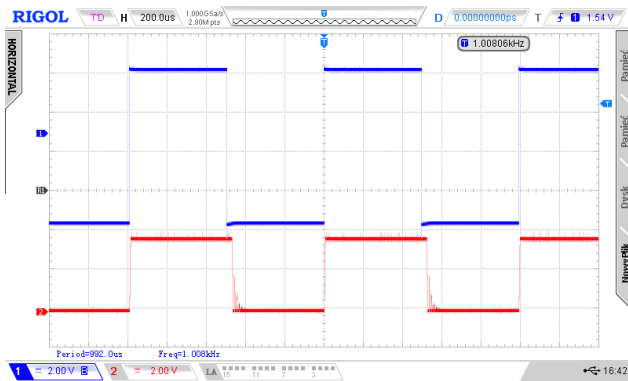

Fig. 7. BPW21 current response for a 1000 Hz square PWM signal.

The VTP1220FBH was tested under conditions similar to the BPW21. In the case of this photodiode, the mapping of the output signal was correct up to the frequency of approx. 5 kHz. While using an identical amplifier circuit as in the BPW21, lower output voltages at the current-to-voltage converter can be observed (Fig. 8).



Fig. 8. VTP1220FBH current response for a 1000 Hz square PWM signal.

The conducted experiments allow to assume that the tested photodiodes allow for a proper operation with a switching frequency of approx. 1 kHz, while the VTP1220FBH diode offers a greater range of correct switching and for this reason it was chosen for the PCB module. Furthermore, the lower photosensitive area means low disturbances in the sensor response [15]. The operating frequency of VTP1220FBH meets the criteria shown in Table 2 and even allows the acquisition process to increase as shown in Table 3.

Table 3

Estimated platform speed assuming 4 measurements at a distance of 4 cm.

| Speed of the platform [km/h] | Speed of the platform [m/s] | Required sampling rate [sample/s] |
|------------------------------|-----------------------------|-----------------------------------|
| 10 | 2.78 | 277.78 |
| 20 | 5.56 | 555.56 |
| 30 | 8.33 | 833.33 |
| 40 | 11.11 | 1111.11 |
| 50 | 13.89 | 1388.89 |
| 60 | 16.67 | 1666.67 |

4. Concept of the measuring module with a light-intensity sensor

The design of the sensor module system for testing the light intensity was based on the concept presented in Ref. 16. The system was based on two LM358 operational amplifiers and a BPW21R photodiode, which was replaced with a selected VTP1220FBH photodiode when used for testing airport lamps [17]. Due to the use of two amplifiers (a current-voltage converter and a non-inverting amplifier), a greater dynamic range can be obtained for low light intensities. An additional advantage is the fact that this system does not have the disadvantages of OP37 amplifiers, and it can be powered with 5 V [18].

The prototype of the Authors' measuring module with I²C communication was prepared based on the ATmega328P microprocessor. Depending on the selected operating mode given by the I²C master, the data can be downloaded continuously (ATmega Free Running Mode) or individually after receiving the command. Additionally, the master can choose from which point of the system the measurement is taken. The overall concept block scheme is presented in Fig. 9.

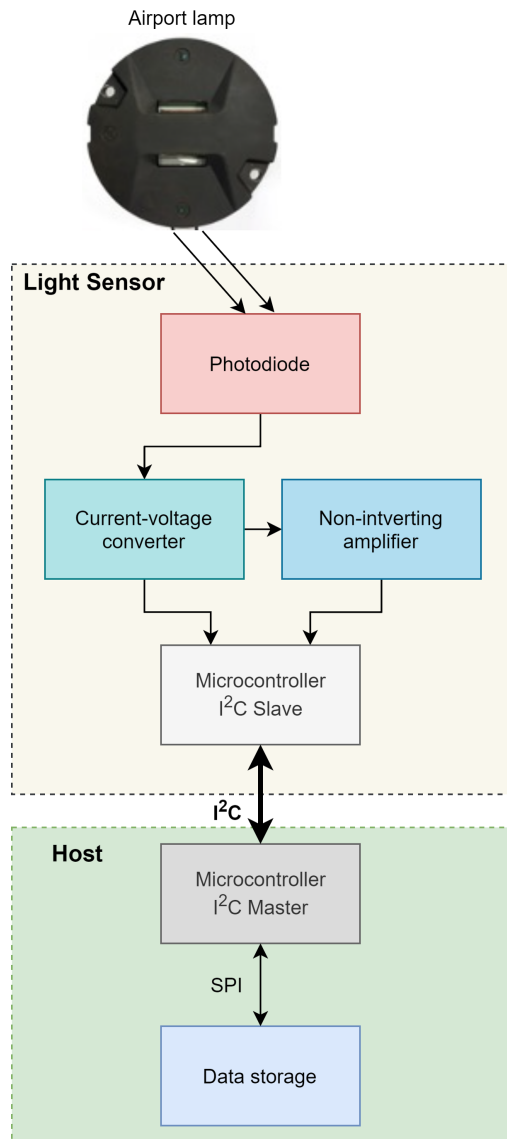

Fig. 9. Overall concept block scheme.

The commands in the I²C protocol have been implemented similarly to the solutions used in the GY-302 module – OneTime / Continuous and LowRes / HighRes. The designed device operates with a default address of 0x3F. To enable the possibility of using more than one module on the I²C protocol, an address change was implemented by physically setting the DIP switch. The range of addresses is of 0x38-0x3F. This solution simplifies data communication because using the TCA9548A multiplexer is not necessary compared to the solutions presented in Refs. 3, 8 and 9. Figures 10 and 11 show I²C waveforms that contain the measurements values taken without and with light source.

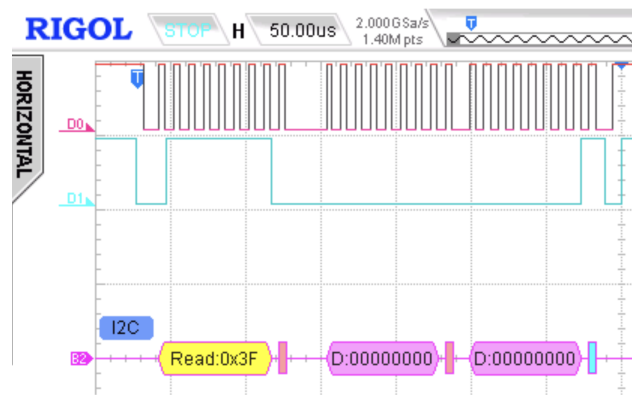

Fig. 10. Example of an I²C frame measurement taken without light source.

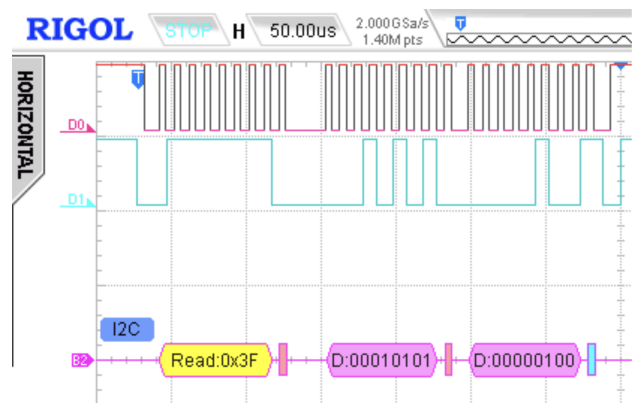

Fig. 11. Example of an I²C frame measurement taken with a light source.

After starting the microcontroller, the first instructions performed are to set the appropriate registers and initialize the communication. The device connects to the I²C bus with a default address of 0x3F and a baud rate of 400 kb/s. The module uses the internal reference voltage of the ATmega328P microprocessor due to the voltage measurements over the full power range. Then, the right alignment of the registers is set which makes it easier to read the full 10-bit measurement. The work of the analogue-to-digital converter is set at 15 000 samples per s, and the related interrupts are activated. In the break that occurs after the completion of the measurement, the values are read after confirming that it started with the less significant part of the result. It is also possible to block the reading of the value in an interrupt if it occurs during the transmission.

After the microcontroller configuration, communication methods via I²C need to be set (Fig. 12). If the slave receives data, it means that the master transmits the command together with the instructions. The complete frame is thus received, and then the appropriate control bits are extracted from it. The first 4 bits set the operating mode (continuous/single measurement), and the next 4 bits set the measurement resolution. Then, the received frame is binary shifted 4 places to the right to extract the more significant bits, and after that, it is converted to the operating mode. Accordingly, the appropriate registers of the analogue-to-digital converter are set. Similarly with the less significant

bits and the choice of the measurement source (unboosted – low resolution, enhanced – high resolution). When the signal reaches the master, the device returns to the latest measurement stored on 2 bits and sends them in the order of the least significant– the most significant. It does not convert the measured value to lux at this point.

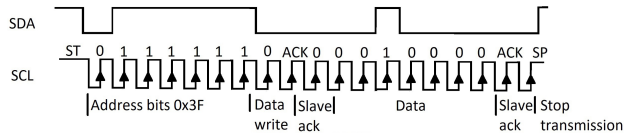

Fig. 12. I²C configuration frame sent during initialization.

Measurement data obtained directly from sensors require additional calculations to enable their correct interpretation. For different lamp colours, the acquisition errors are different, therefore, the measurement result must be approximated each time. Therefore, the sensor was calibrated after performing several parallel series of measurements using a certified SONOPAN LUXMETER L-51 light meter. The collected characteristics made it possible to determine the conversion factor in the form of a second-degree polynomial and obtain a value expressed in lux [2].

Taking into account all the design assumptions related to the construction of the light intensity sensor module, the circuit diagram was prepared (Fig. 13). The system is equipped with additional elements such as: double gold pin connector working as a communication interface, precise potentiometer to change the gain, address DIP switch, reset button, and LED indicator. The filter capacitor C4 100 nF is optional.

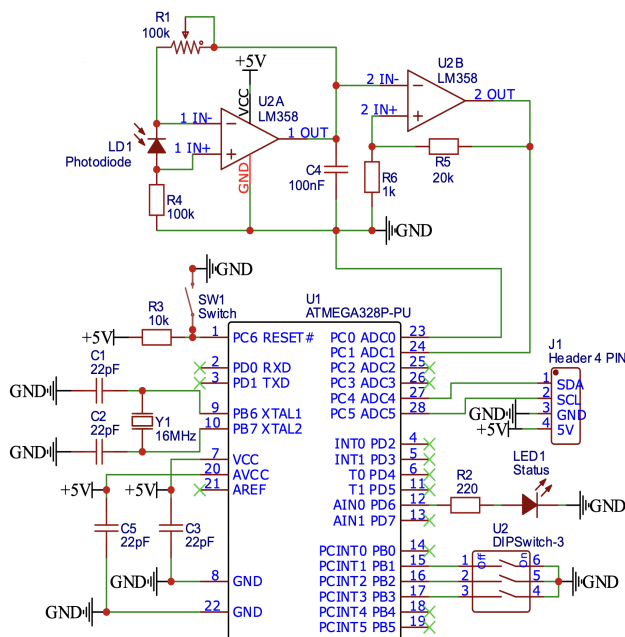

Fig. 13. Circuit diagram.

The LED diode is used to indicate the operating status of the device. During each transmission of the frame, the LED is turned off which gives the impression of blinking with a frequent communication. Thanks to this, the user can easily observe the status of:

- data transmission (LED flashes),
- device is active but not transmitting (continuous light),
- device is switched off / blocked (LED off).

Figure 14 shows a designed prototype of PCB of the light-intensity sensor with a photodiode [17]. Such sensors can be mounted in the form of a measuring matrix for airport lamp quality testing.

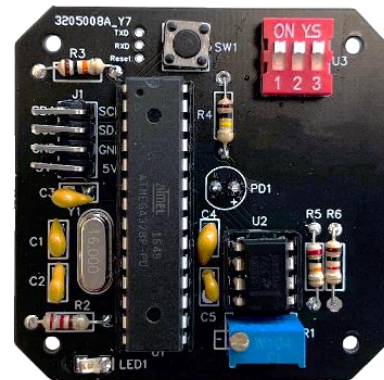

Fig. 14. PCB realization of the light-intensity sensor with a photodiode.

In addition to the previously described elements, a button has been added that allows to reset the device and connectors inside the board itself (TX, RX, reset), also allowing to update a software directly to the microcontroller on the board. The photodiode is mounted on the opposite side to the rest of the elements to minimize the chance of blocking the light by the element from the PCB and enable the module to be mounted in a special cover.

It should be noted that the size of the PCB (50.8 × 50.8 mm) has been selected to allow easy installation in the measuring matrix when using several modules, connected in series. Placing the photodiode in the central point was critical to enable measuring the main beam of the tested lamp after mounting the sensor in the matrix housing. Also, the PCB colour (black) was chosen to reduce the risk of light reflections and, thus, reduce the occurrence of light intensity disturbance.

5. Conclusions

The microprocessor sensor module designed to measure the intensity of visible light is based on the VTP1220FBH photodiode. Due to the characteristics of the photosensitive element, it is possible to use the module for mounting on the measurement platform for the quality testing of airport lamps.

The advantage of the proposed solution is fast communication and use of the I²C protocol. The possibility of selecting one of the eight addresses with the use of physical switches to determine the binary state has also been implemented. Additionally, these addresses can be set to any value when programming the microcontroller. Thanks to these solutions, it is possible to simultaneously connect many modules in series in the form of a multipoint measurement matrix.

Due to the size of the measuring platform device for testing the quality of operation of airport lamps, the sensor

miniaturization was not required at this stage of the works. An additional advantage of the THT assembly solution is the possibility of quick replacing the microprocessor and its easy reprogramming. In addition, in case of further research development and finding an even better photosensitive element, its rapid replacement is possible.

Acknowledgements

This research was funded partly by the 2022 subvention and partly with the SMART4ALL EU Horizon 2020 project, Grant Agreement No 872614.

References

- [1] Certification Specifications (CS) and Guideline Material (GM) for Aerodrome Design Edition 3, Annex to Decision No. 2016/027/Rof the EASA Executive Director, European Aviation Safety Agency. <https://www.easa.europa.eu/en/downloads/21730/en> (2016).
- [2] Suder, J., Maciejewski, P., Podbucki, K., Marciniak, T. & Dąbrowski, A. Platforma pomiarowa do badania jakości działania lamp lotniskowych (Measuring platform for quality testing of airport lamps). *Pomiary Automatyka Robotyka PAR* **23**, 5–13 (2019). https://doi.org/10.14313/PAR_232/5 (in Polish)
- [3] Podbucki, K., Suder, J., Marciniak, T. & Dąbrowski, A. Elektroniczna matryca pomiarowa do badania lamp lotniskowych (Electronic measuring matrix for testing airport lamps). *Przełąd Elektrotechniczny* **97**, 47–51 (2021). <https://doi.org/10.15199/48.2021.02.12> (in Polish)
- [4] Suder, J., Podbucki, K., Marciniak, T. & Dąbrowski, A. Spectrum sensors for detecting type of airport lamps in a light photometry system. *Opto-Electron. Rev.* **29**, 133–140 (2021). <https://doi.org/10.24425/opelre.2021.139383>
- [5] Suder, J., Podbucki, K., Marciniak, T. & Dąbrowski, A. Low complexity lane detection methods for light photometry system. *Electronics* **10**, 1665 (2021). <https://doi.org/10.3390/electronics10141665>
- [6] BH1750 Digital 16bit Serial Output Type Ambient Light Sensor IC Technical Note. <https://www.mouser.com/datasheet/2/348/bh1750fvi-e-186247.pdf> (2011).
- [7] Krac, E. & Górecki, K. Wpływ kąta padania światła na wartości natężenia oświetlenia zmierzone za pomocą czujników fotometrycznych (Influence of the angle of incidence of light on the values of illuminance measured with photodetectors). *Przełąd Elektrotechniczny* **97**, 214–217 (2021). <https://doi.org/10.15199/48.2021.12.44> (in Polish)
- [8] Sitompul, D. S. D., Surya, F. E., Suhandi, F. P. & Zakaria, H. Runway Edge Light Photometry System by Using Drone-Mounted Instrument. in *International Symposium on Electronics and Smart Devices (ISESD)* 1–5 (2019). <https://doi.org/10.1109/ISESD.2019.8909498>
- [9] Sitompul, D. S. D., Surya, F. E., Suhandi, F. P. & Zakaria, H. Horizontal Scanning Method by Drone Mounted Photodiode Array for Runway Edge Light Photometry. in *International Seminar on Intelligent Technology and Its Applications (ISITIA)* 41–45 (2019). <https://doi.org/10.1109/ISITIA.2019.8937211>
- [10] Gao, J., Luo, J., Xu, A. & Yu, J. Light Intensity Intelligent Control System Research and Design Based on Automobile Sun Visor of BH1750. in *29th Chinese Control And Decision Conference (CCDC)* 3957–3960 (2017). <https://doi.org/10.1109/CCDC.2017.7979192>
- [11] Grove – Light Sensor v1.2. *Seeed Development Limited* https://seeedoc.github.io/Grove-Light_Sensor_v1.2/ (2016).
- [12] BPW21TO39 Ambient Light Sensor Datasheet. *ams-OSRAM AG* https://dammedia.osram.info/media/resource/hires/osram-dam-5984961/BPW%2021_EN.pdf (2022).
- [13] Ptak, P., Górecki, K. & Gensikowski, M. Porównanie właściwości dynamicznych wybranych czujników fotometrycznych (Comparison of dynamic properties of the selected photometric sensors). *Przełąd Elektrotechniczny* **96**, 112–116 (2020). <https://doi.org/10.15199/48.2020.12.21> (in Polish)
- [14] Ambient Light Sensors VTP1220FBH Product Description. *Exelitas* <https://www.tme.eu/Document/99fa8b97bc9fac9fd65b9c88e771e8d1/2.pdf> (2022).
- [15] Raes, W., Bastiaens, S., Plets, D. & Stevens, N. Assessment of the Influence of Photodiode Size on RSS-Based Visible Light Positioning Precision. *IEEE SENSORS* 1–3 (2019). <https://doi.org/10.1109/SENSORS43011.2019.8956543>
- [16] Hudzikowski, A. Luksomierz kit 2974 AVT. *Elektronika dla wszystkich EDW* **03/11**, 56–58, 2011. <https://serwis.avt.pl/manuals/AVT2974.pdf> (in Polish)
- [17] Mańczak, W. *Development of a microprocessor matrix to measure the lightning intensity of airport lamps*. (Poznan University of Technology, 2022).
- [18] Alferink, F. Fast Lux-meter: Electronic Measurements. *Meettechniek.info*. <https://meettechniek.info/diy-instruments/lux-meter.html> (2013).