



## Research paper

# Analysis of deflections of reinforced concrete slab in the rectified water-storage tank

Krzysztof Gromysz<sup>1</sup>

**Abstract:** The presented analysis concerns deflections of the reinforced concrete slab in the fire-fighting water storage tank with volume of 950 m<sup>3</sup>. It was built on human-altered soil which led to deflection of the tank. When water was pumped out from the tank, rectification was performed. The tank and its slab foundation were non-uniformly elevated by means of hydraulic jacks. These jacks were installed under the slab, on foundation made of concrete block stacks, which were pressed into the ground. The computational analysis was conducted for displacements and deflections of the slab supported on the jacks. The number of jacks under the slab and stiffness of jack supports on the stacks were the variable parameters of the model. Stiffness of the jack supports was found to have non-significant impact on deflections of the foundation slab of the rectified tank. On the other hand, the number of jacks under the tank affected both deflections of the slab and displacements of the whole tank. The greatest deflection of the tank slab supported on three jacks was 15.233 mm, and the smallest one was 10.435 mm at 32 jacks.

**Keywords:** deflection of slab foundation, rectification of building structures, support

<sup>1</sup>DSc., PhD., Eng., Silesian University of Technology, Faculty of Civil Engineering, ul. Akademicka 5, 44-100 Gliwice, Poland, e-mail: [krzysztof.gromysz@polsl.pl](mailto:krzysztof.gromysz@polsl.pl), ORCID: 0000-0002-7778-8620

## 1. Introduction

Vertical deflection is a common defect found in constructions [1], which is usually caused by insufficient load-bearing capacity of subsoil [2]. This problem refers to different types of constructions, such as residential buildings [3], historic towers [4], churches [5], as well as grain elevators. Vertical deflection of the construction can be also the effect of the non-uniform depression of mining areas [6], which is caused by compression of the voids left after underground extraction works [7]. Deflection can damage constructions with wall building structure [8], frame structures [9], can increase the risk of building operation [10], and the risk of the collapse [11]. Deflected constructions are usually stabilized by reinforcing their foundation with piles [12]. The deflected single elements of the structure are stabilised in a new position [13]. In particular situations, structural elements [14] or whole constructions [15] are rectified. It can be done by removing soil from the building parts that are situated too high [16] or by elevating some parts of the building that are situated too low [17]. The paper [18] describes how the parameters of the rectified tank were determined from the in-situ tests. This paper describes the analysis of displacement and deflection of the reinforced concrete slab in the tank, which was performed on the basis of the numerical calculations. Displacements and deflections of this element were caused by changes of the tank structural arrangement. The tank was placed on the system of flexible supports composed of hydraulic jacks and their bearings made of stacks of concrete blocks introduced into the ground. The researchers conducted so far has been focused mainly on the impact of: substrate stiffness [19], type of reinforcement [20] or the presence of ribs [21] on their deflection.

## 2. Description of the tank and its rectification

The fire-fighting steel tank for water storage with a capacity of 950 m<sup>3</sup>, has a cylindrical shape with an inner diameter of 12.221 m (Fig. 1a) and a height of 8.520 m (Fig. 1b). Its shell is made of 3 mm thick metal sheet and reinforced with corner brackets placed at four levels. The roof framing is composed of steel bars made of cold-formed profiles supported on the reinforced edge of the shell and on two columns placed inside the tank. A three-layer panel with polyurethane core is used as the roofing material. Inside the tank, there are water supply systems and components of the fire-fighting system used to pump out water. Tightness is ensured by PVC film of 1.5 mm in thickness, which is inside the tank.

The structure is placed on the reinforced concrete slab which has a regular hexagonal shape with a side length of 5.413 m. The slab has a thickness of 300 mm (Fig. 2a).

However, the thickness increases gently up to 600 mm at the edges and the reinforced concrete beam formed around the slab has a cross section ( $b/h$ ) 800 mm/600 mm (Fig. 2b). A layer of 70 mm thick lean concrete is placed under the slab. The 2-way top and bottom reinforcement of the slab is composed of rebars with a diameter of 12 mm and the spacing of 150 mm. The bottom reinforcement of the beam around the slab contains six rebars having a diameter of 16 mm and stirrups made of bars with a diameter of 8 mm and the spacing of 250 mm.

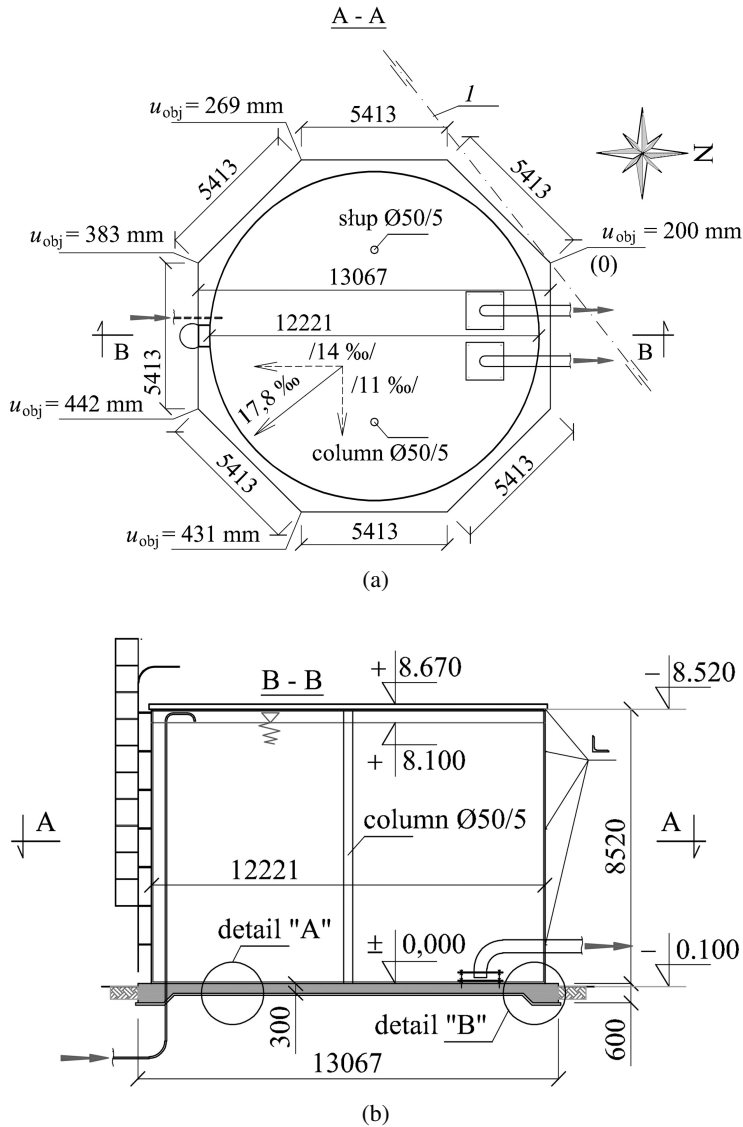

Fig. 1. Tested steel water tank: (a) tank view, (b) cross-section, 1 – centre of rotation during the rectification, 17.8‰ – resultant deflection, 14‰ – component of deflection [20]

The tank was deflected by 17.8 mm/m in the south-east direction, and therefore it was rectified [20]. For that purpose, stacks of concrete blocks were pressed into the ground under reinforced concrete beams which were part of the foundation. Hydraulic piston jacks, which took the tank weight after pumping out water from the tank and generating the force inside, were placed on such supports (Fig. 3).

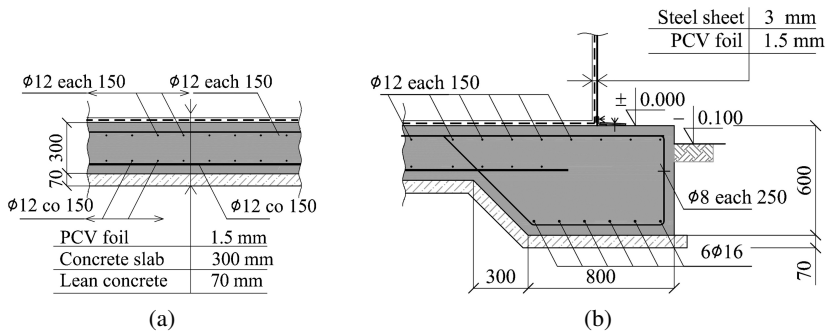

Fig. 2. Reinforced concrete slab foundation of the tank: (a) detail “A” from Fig. 1, (b) detail “B” from Fig. 1

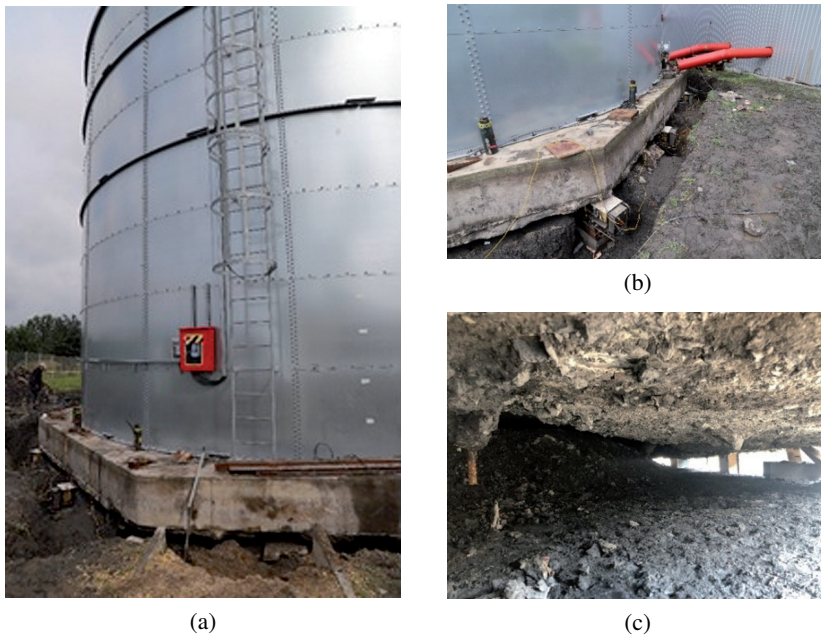

Fig. 3. The tank during rectification: (a) the tank on the jacks, (b) the jacks placed on the supports made of concrete block stacks pressed into the ground, (c) space created between the slab base and the ground after elevating the tank, which is placed on the jacks

The tank was non-uniformly elevated with the jacks by rotating it around the axis  $I$  (Fig. 1), which led to vertical position. The minimum elevation  $u_{obj}$  was 200 mm, and the maximum one – 431 mm (Fig. 1). Space between the slab base and the ground arranged after the rectification was filled with concrete, while stacks of concrete blocks pressed under the slab were kept.

### 3. Research programme

The analysis focused on the reinforced concrete slab foundation of the tank placed on the supports. These supports were the jacks placed on the foundation made of concrete block stacks, which were pressed into the ground. The tank was emptied and its self weight was the only load. Then, the force  $Q_{g,i}$ , whose value resulted from dead load and stiffness of individual components of the structure, was generated in each  $i$ -th jack. The tank placed on the jacks was subjected to displacements  $u_{obj-g}$  caused by its self weight (Fig. 4).

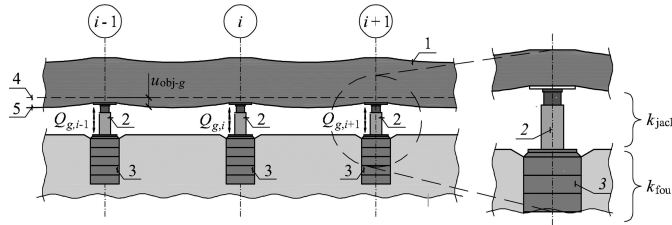

Fig. 4. Displacements  $u_{obj-g}$  of the reinforced concrete slab and force  $Q_{g,i}$  in the supports while the tank was placed on the temporary supports: 1 – elevated tank, 2 – jack, 3 – jack foundation, 4 – position of the tank before installing the jacks, 5 – position of the tank when the jacks took the tank weight;  $k_{jack}$  – jack stiffness,  $k_{fou}$  – foundation stiffness

The discussed analysis was aimed at testing the effect of the model variables, which include the  $n$  number of the supports under the tanks and the foundation stiffness  $k_{fou}$ , on the slab displacement. The analyses were conducted for the  $n$  number of the jacks equal to 3, 4, 8, 16, 32 (Fig. 5) and six different values of the foundation stiffness equal to: 50 MN/m, 100 MN/m, 150 MN/m, 200 MN/m, 250 MN/m and the rigid foundation.

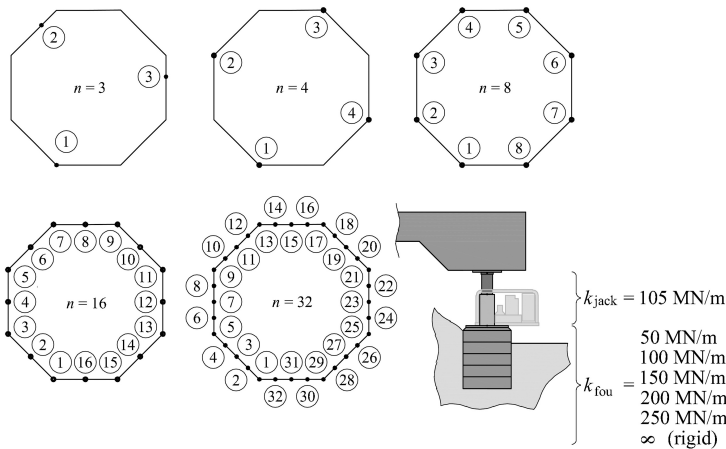

Fig. 5. The analysed variables for the model:  $n$  number of the supports equal to 3, 4, 8, 16, and 32 and the foundation stiffness  $k_{fou}$  of the jacks equal to: 50 MN/m, 100 MN/m, 150 MN/m, 200 MN/m, 250 MN/m, and  $k_{fou} = \infty$  (rigid)

The analysed model (Fig. 6a) consisted of the reinforced concrete slab, the steel tank, the jacks and their foundation. A slab of variable thickness in accordance with the survey (Fig. 1 and Fig. 2) having elasticity modulus  $E_c = 32$  GPa, shear modulus  $G_c = 13.33$  GPa, the Poisson's ratio  $\nu = 0.2$  and weight density  $\gamma_c = 25$  kN/m<sup>3</sup>, was used as the model of reinforced concrete foundation slab (Fig. 6b). The steel tank was modelled with a 3 mm thick coating of the material having the following parameters: elasticity modulus  $E_c = 200$  GPa, shear modulus  $G_c = 76.9$  GPa, the Poisson's ratio  $\nu = 0.3$ , and weight density  $\gamma_c = 78.5$  kN/m<sup>3</sup>. The hinged connection was used as the connection between the foundation slab and the tank. The supports were modelled with two stiffness values  $k_{\text{jack}}$  of the jack and the foundation  $k_{\text{fou}}$  connected in series (Fig. 6c). Stiffness  $k_{\text{jack}}$  determined during the tests [20] was constant and equal to 105 MN/m. Stiffness  $k_{\text{fou}}$  of the foundation depended on the length of the concrete block stacks pressed into the ground.

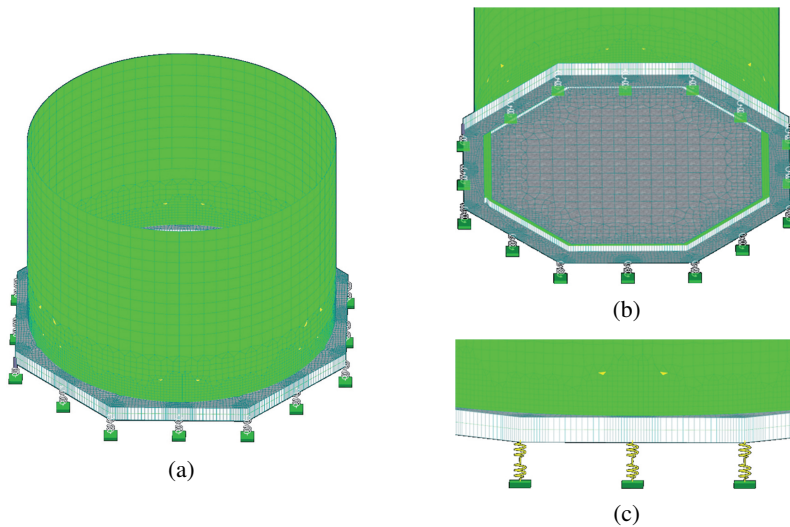

Fig. 6. The tank model: (a) general view, (b) foundation slab, (c) stiffness values  $k_{\text{jack}}$  and  $k_{\text{fou}}$  which form the supports

## 4. Analysis of test results

The analysis of the results was carried out in relation to the deflections of the foundation slab and force values in the jacks.

### 4.1. Deflections of the foundation slab

When the tank was placed on the jacks, it was subjected to displacements  $u_{\text{obj-g}}$  (Fig. 4). Figure 7 presents displacements of the tank model  $u_{\text{obj-g},\alpha}$  in the  $\alpha$ - $\alpha$  section crossing the opposite corners of the slabs calculated for two extreme values of the analysed values of the

foundation stiffness  $k_{fou} = 50 \text{ MN/m}$  (Fig. 7a) and the rigid foundation ( $k_{fou} = \infty$ , Fig. 7b). Relevant lines in Figure correspond with the number  $n$  of the jacks equal to  $n = 3, 4, 8, 16,$  and  $32$  at the arrangement of the jacks shown in Fig. 5. The value of displacements  $u_{obj-g,\alpha}$  comes from stiffness values  $k_{fou}$  and  $k_{jack}$  connected in series and the slab deflection, which is its stress-strain measure. Hence, the analysed effect of the number  $n$  of the jacks and the stiffness  $k_{fou}$  on the net deflection of the slab is described below. The net deflection was defined as the maximum distance between the line running through the opposite corners of the slab and the deflection line determined through the section  $\alpha - \alpha$  (Fig. 8). The net deflection value was marked as  $u_{obj-g-max,\alpha}$ , and these values for the analysed range of variables  $n$  and  $k_{fou}$  are shown in Table 1.

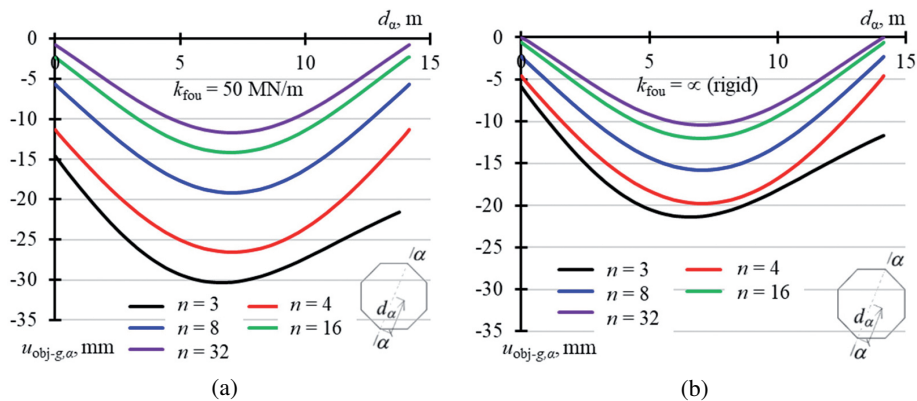

Fig. 7. Displacements  $u_{obj-g,\alpha}$  of the foundation slab resulting from dead weight after placing  $n$  jacks under the slab: (a) displacements at the foundation stiffness  $k_{fou} = 50 \text{ MN/m}$ , (b) displacements at the rigid foundation of the jacks

Table 1. Net deflection  $u_{obj-g-max,\alpha}$  of the slab, in mm, depending on the number  $n$  of the jacks and the stiffness  $k_{fou}$  of the jack foundation

$k_{fou}, \text{MN/m}$	50	100	150	200	250	Rigid
$n = 3$	11.961	11.961	11.961	11.961	11.961	11.961
$n = 4$	15.222	15.222	15.222	15.223	15.222	15.223
$n = 8$	13.496	13.496	13.497	13.496	13.496	13.496
$n = 16$	11.907	11.777	11.681	11.642	11.608	11.451
$n = 32$	10.966	10.824	10.751	10.704	10.671	10.435

Graphical presentation of  $u_{obj-g-max,\alpha}$  is shown in Fig. 8a and Fig. 8b. For  $n = 3, 4, 8,$  the value  $u_{obj-g-max,\alpha}$  did not depend on the support stiffness. When  $n = 3$ , then the statically determined system occurred. When  $n = 4$  and  $8$ , all the jacks were symmetrically

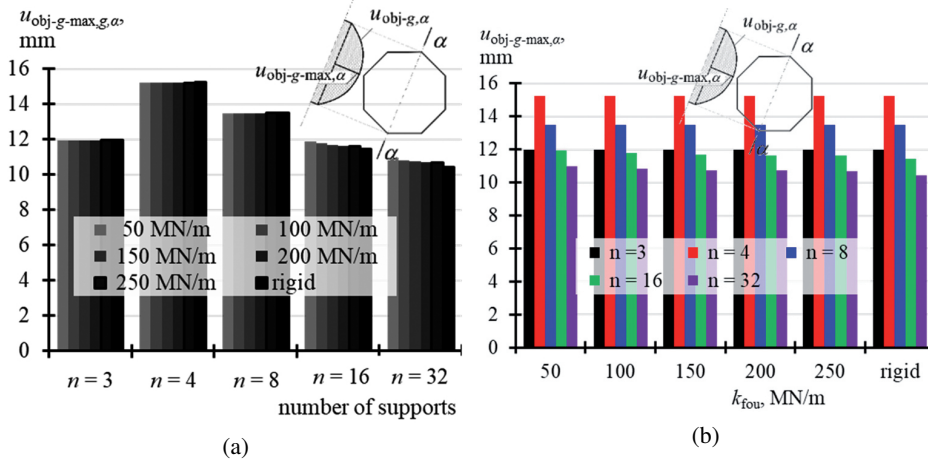

Fig. 8. Maximum values of the net deflection  $u_{obj-g-max,\alpha}$  of the slab: (a) deflections depending on the number  $n$  of the supports for different values  $k_{fou}$ , (b) deflections depending on  $k_{fou}$  for various numbers of the  $n$  supports

built in corners of the regular hexagonal slab. For  $n = 3$   $u_{obj-g-max,\alpha}$  was 11.961 mm, for  $n = 4$   $u_{obj-g-max,\alpha}$  was 15.222 mm, and for  $n = 8$   $u_{obj-g-max,\alpha}$  took the value of 13.496 mm. When  $n = 16$  and 32, the net deflection value depended on the foundation stiffness and was decreasing with an increasing value  $k_{fou}$ .

For  $n = 16$   $u_{obj-g-max,\alpha}$  ranged from 11.451 mm at the infinite stiffness of the foundation  $k_{fou}$  to 11.907 mm when  $k_{fou}$  was 50 MN/m. For  $n = 32$   $u_{obj-g-max,\alpha}$  ranged from 10.435 mm at the infinite stiffness of the foundation  $k_{fou}$  to 11.966 mm when  $k_{fou}$  was 50 MN/m. Thus, taking into account the stress-strain measure for the slab, placing the tank on four jacks was the least favourable foundation, while 32 jacks with rigid foundation were found to be the most favourable foundation.

### 4.2. Force values in the jacks

After installing jacks on the foundation under the tank, the forces  $Q_{g,i}$  resulting from dead weight of the tank were generated in these new supports. When  $n = 3$ , the reaction forces did not depend on the foundation stiffness as the structure was statically determinate. Then, the reaction forces were  $Q_{g,1} = 431.30$  kN,  $Q_{g,2} = Q_{g,3} = 457.80$  kN (Table 2). When  $n = 4$  and 8, all the jacks were built in corners of the regular hexagonal slab. Then, the reaction force  $Q_{g,i}$ , as the analysed above net deflection, were the same for a given  $n$  and did not depend on stiffness of the foundation  $k_{fou}$ . For  $n = 4$  the reaction force  $Q_{g,i}$  was 336.72 kN (Fig. 9a), and for  $n = 8$   $Q_{g,i}$  was 168.35 kN (Fig. 9b). When  $n = 16$  and  $n = 32$ , the reaction forces varied, and this variation was greater at the greater number of the supports. Higher values of the reaction forces were observed in the jacks placed in the mid-length of the foundation side and at more rigid supports (Fig. 9c, Fig. 9d). The values



$Q_{g,i}$  for  $n = 16$  ranged from 45.50 kN to 66.65 kN for the jacks in the corners, and from 101.69 kN to 122.82 kN for the jacks in the mid-length of the sides. For  $n = 32$  the values  $Q_{g,i}$  were from ca. 0 to 21.33 kN at the jacks in the corners, from 46.21 kN to 51.51 kN for the jacks in the mid-length of the sides, and from 54.60 kN to 69.42 kN for the jacks in 1/4 length of the side. The performed analysis indicates that lower values of the reaction forces were in the corners, and these lower values were observed for higher values  $k_{fou}$ . Horizontal axes shown in Figure 9 represent distance  $d_{i,1}$  between the  $i$ -th jack and the first one.

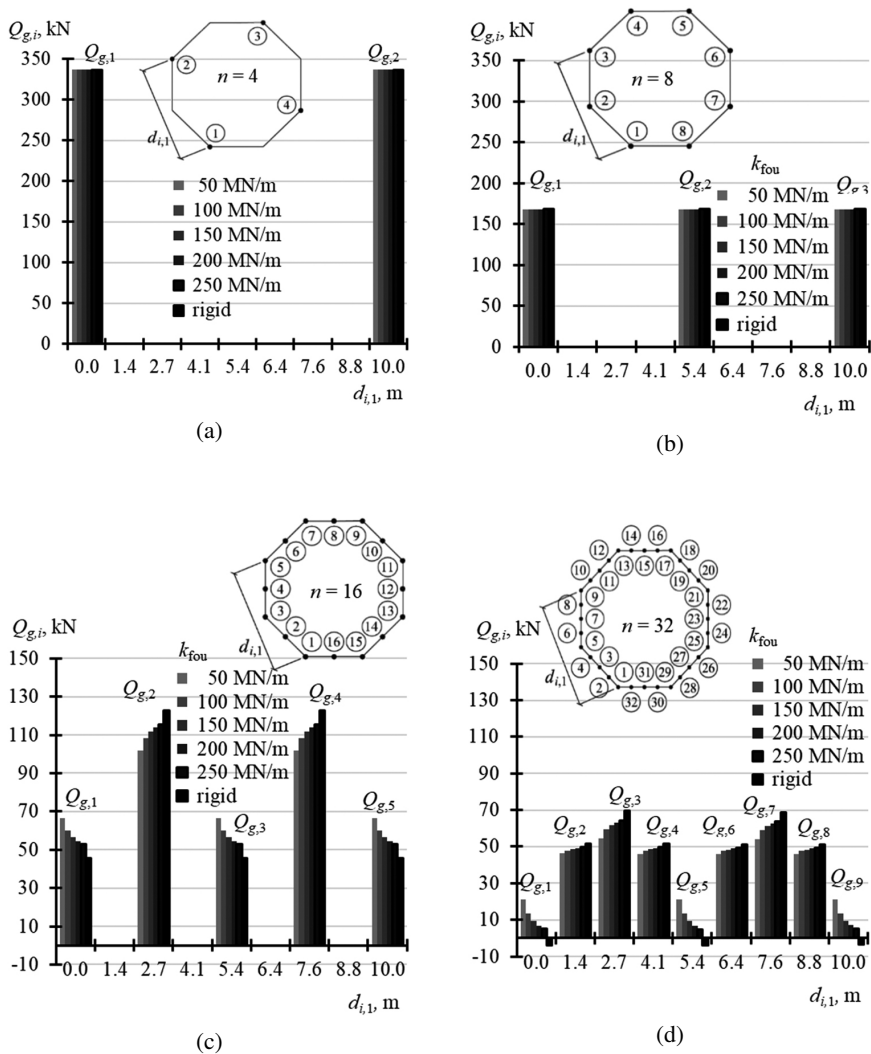

Fig. 9. The reaction force  $Q_g$  in the jacks caused by dead weight depending on the  $n$  number of the jacks and stiffness  $k_{fou}$  of jack foundation: (a)  $n = 4$ , (b)  $n = 8$ , (c)  $n = 16$ , (d)  $n = 32$

Table 2. The reaction force  $Q_{g,i}$ , kN, in the jacks depending on the  $n$  number of the jacks and stiffness  $k_{fou}$  of the jack foundation

$n$	$Q_{g,i}$	$k_{fou}$ , MN/m					
		50	100	150	200	250	rigid
3	$Q_{g,1}$	431.30	431.30	431.30	431.30	431.30	431.30
	$Q_{g,2}$	457.80	457.80	457.80	457.80	457.80	457.80
4	$Q_{g,1}$	336.72	336.72	336.72	336.72	336.72	336.72
8	$Q_{g,1}$	168.35	168.35	168.35	168.35	168.35	168.35
16	$Q_{g,1}$	66.65	60.05	56.59	54.46	52.90	45.50
	$Q_{g,2}$	101.69	108.28	111.74	113.86	115.43	122.82
32	$Q_{g,1}$	21.33	13.49	9.37	6.83	4.96	-3.89 (ca. 0)
	$Q_{g,2}$	46.21	47.83	48.69	49.22	49.62	51.51
	$Q_{g,3}$	54.60	59.27	61.70	63.19	64.28	69.42

## 5. Conclusions

Rectifying by non-uniform elevation of the deflected tank required the prior installation of jacks under its foundation. For the rectified water storage tank with volume of 950 m<sup>3</sup>, whose foundation was made from the reinforced concrete slab in the shape of regular hexagonal and the side length of 5.413 m, the jacks were supported on stacks of concrete blocks pressed into the ground. The rectangle with sides of 500 mm and 380 mm in length were the stack base, and stiffness of the jack foundation was greater for higher stacks.

Displacement of the tank slab on the jacks was caused by stiffness of the jacks connected in series, stiffness of the jack foundation placed on the stacks, and the slab deflection which is its stress-strain measure. The maximum deflection of the slab against its corners was defined as the net deflection.

When the number of jacks under the slab was 3, 4 and 8, the net deflection did not depend on the foundation stiffness. The calculated net deflection was equal to 11.961 mm, 15.222 mm, and 13.496 mm, respectively. When the number of supports was greater than 8, then the net deflection depended on the foundation stiffness and was decreasing with an increasing stiffness of the stack. When the number of supports was 16, the calculated net deflection ranged from 11.451 mm at the infinite stiffness of the foundation to 11.907 at the stiffness equal to 50 MN/m. For 32 supports, the net deflection values for the relevant stiffness of the supports ranged from 10.435 mm to 11.966 mm.

These calculations were the base for the rectification process of the empty tank for water storage using 16 jacks installed under the slab, with the foundation stiffness for each jack equal to 150 MN/m.

## Acknowledgements

Funding: Publication was supported under the rector's pro-quality grant. Silesian University of Technology; Grant No. 03/020/RGJ21/0102.

## References

- [1] W. Kamiński, "Determination of vertical displacements by using the hydrostatic levelling systems with the variable location of the reference sensor", *Archives of Civil Engineering*, vol. 68, no. 1, pp. 189–206, 2022, DOI: [10.24425/ACE.2022.140163](https://doi.org/10.24425/ACE.2022.140163).
- [2] A. M. Puzrin, E. E. Alonso, and N. M. Pinyol, "Bearing Capacity Failure: Transcona Grain Elevator, Canada", in *Geomechanics of Failures*. Dordrecht, New York: Springer, 2010, pp. 67–84, DOI: [10.1007/978-90-481-3531-8\\_4](https://doi.org/10.1007/978-90-481-3531-8_4).
- [3] M. Kijanka and M. Kowalska, "Inclined Buildings – Some Reasons and Solutions", *IOP Conference Series: Materials Science and Engineering*, vol. 245, no. 2, art. no. 022052, 2017, DOI: [10.1088/1757-899X/245/2/022052](https://doi.org/10.1088/1757-899X/245/2/022052).
- [4] G. Macchi, "Stabilization of the Leaning Tower of Pisa", in *Structures Congress 2005*. ASCE, 2005, pp. 1–11, DOI: [10.1061/40753\(171\)152](https://doi.org/10.1061/40753(171)152).
- [5] E. Ovando-Shelley and E. Santoyo, "Underexcavation for Leveling Buildings in Mexico City: Case of the Metropolitan Cathedral and the Sagrario Church", *Journal of Architectural Engineering*, vol. 7, no. 3, pp. 61–70, 2001, DOI: [10.1061/\(ASCE\)1076-0431\(2001\)7:3\(61\)](https://doi.org/10.1061/(ASCE)1076-0431(2001)7:3(61)).
- [6] J. Orwat, "Causes analysis of occurrence of the terrain surface discontinuous deformations of a linear type", *Journal of Physics: Conference Series*, vol. 1426, art. no. 012016, 2020, DOI: [10.1088/1742-6596/1426/1/012016](https://doi.org/10.1088/1742-6596/1426/1/012016).
- [7] W. Piwowarski, P. Strzałkowski, and R. Ścigala, "Analysis of rock mass destruction processes with different activity diagrams", *Acta Geodynamica et Geomaterialia*, vol. 14, no. 1, pp. 83–92, 2017, DOI: [10.13168/AGG.2016.0030](https://doi.org/10.13168/AGG.2016.0030).
- [8] P. Strzałkowski, "Some Remarks on Impact of Mining Based on an Example of Building Deformation and Damage Caused by Mining in Conditions of Upper Silesian Coal Basin", *Pure and Applied Geophysics*, vol. 176, no. 6, pp. 2595–2605, 2019, DOI: [10.1007/s00024-019-02127-1](https://doi.org/10.1007/s00024-019-02127-1).
- [9] C. Ren and B. Yan, "Experimental research of the influence of differential settlement on the upper frame structures", in *Proceeding of 3rd International Conference on Mechanical Engineering and Intelligent Systems*. 2015, pp. 539–544, DOI: [10.2991/icmeis-15.2015.100](https://doi.org/10.2991/icmeis-15.2015.100).
- [10] R. Al' Malul and M. Gadzhuntsev, "The reliability of multistory buildings with the effect of non-uniform settlements of foundation", in *E3S Web Conferences*. 2018, art. no. 02040, DOI: [10.1051/e3sconf/20183302040](https://doi.org/10.1051/e3sconf/20183302040).
- [11] R.B. Peck and F.G. Bryant, "The Bearing-Capacity Failure Of The Transcona Elevator", *Géotechnique*, vol. 3, no. 5, pp. 201–208, 1953, DOI: [10.1680/geot.1953.3.5.201](https://doi.org/10.1680/geot.1953.3.5.201).
- [12] H.P. Yin, C.L. Li, and Z.Y. Xie, "Analysis on Deviation Rectification and Reinforcement of Buildings", *Advanced Materials Research*, vol. 255–260, pp. 59–64, 2011, DOI: [10.4028/www.scientific.net/AMR.255-260.59](https://doi.org/10.4028/www.scientific.net/AMR.255-260.59).
- [13] K. Gromysz, L. Szoblik, E. Cyrulik, A. Tanistra-Rózanowska, Z. Drabczyk, and S. Jancia, "Analysis of stabilisation method of gable walls of a barrack located at the section BI of the former KL Auschwitz II-Birkenau", *MATEC Web of Conferences*, vol. 284, art. no. 08004, 2019, DOI: [10.1051/matecconf/201928408004](https://doi.org/10.1051/matecconf/201928408004).
- [14] K. Gromysz, L. Szoblik, E. Cyrulik, A. Tanistra- Rózanowska, Z. Drabczyk, and S. Jancia, "Rectification of walls of the historical brick barrack on the site of the former German Nazi Concentration and Extermination Camp KL Auschwitz - Birkenau", *IOP Conference Series: Materials Science and Engineering*, vol. 603, no. 4, art. no. 042070, 2019, DOI: [10.1088/1757-899X/603/4/042070](https://doi.org/10.1088/1757-899X/603/4/042070).
- [15] K. Gromysz, "Rectification an 11-Storey Vertically Deflected Residential Building", *Procedia Engineering*, vol. 57, pp. 382–391, 2013, DOI: [10.1016/j.proeng.2013.04.050](https://doi.org/10.1016/j.proeng.2013.04.050).

- [16] K. Gromysz, "Methods of Removing Buildings Deflection Used in Poland", *IOP Conference Series: Materials Science and Engineering*, vol. 245, no. 3, art. no. 032096, 2017, DOI: [10.1088/1757-899X/245/3/032096](https://doi.org/10.1088/1757-899X/245/3/032096).
- [17] M. Smolana and K. Gromysz, "Effect of Eccentricity of Applied Force and Geometrical Imperfections on Stiffness of Stack of Cuboidal Steel Elements", *Materials*, vol. 13, no. 14, art. no. 3174, 2020, DOI: [10.3390/ma13143174](https://doi.org/10.3390/ma13143174).
- [18] K. Gromysz, "Analysis of Parameters of a Rectified Tank on the Basis of In-Situ Tests", *Materials*, vol. 14, no. 14, art. no. 3881, 2021, DOI: [10.3390/ma14143881](https://doi.org/10.3390/ma14143881).
- [19] P. M. Lewiński, "Interaction of RC and PC Cylindrical Silos and Tanks with Subsoil", *Archives of Civil Engineering*, vol. 66, no. 4, pp. 249–267, 2020, DOI: [10.24425/ACE.2020.135220](https://doi.org/10.24425/ACE.2020.135220).
- [20] Y. Wang, H.T. Liu, G.F. Dou, C.H. Xi, and L. Qian, "Experimental Study of Multi-Ribbed One-Way Composite Slabs Made of Steel Fibre, Foam, and Normal Concrete", *Archives of Civil Engineering*, vol. 64, no. 2, pp. 79–96, 2018, DOI: [10.2478/ace-2018-0018](https://doi.org/10.2478/ace-2018-0018).
- [21] P. Subashree and R. Thenmozhi, "Experimental Study of Hybrid Rubberized Composite Slabs", *Archives of Civil Engineering*, vol. 64, no. 4, pp. 22–29, 2018, DOI: [10.2478/ace-2018-0060](https://doi.org/10.2478/ace-2018-0060).

## Analiza ugięć żelbetowej płyty fundamentowej rektyfikowanego zbiornika na wodę

**Słowa kluczowe:** ugięcie płyty fundamentowej, rektyfikacja konstrukcji budowlanych, sztywność podpór

### Streszczenie:

Przedmiotem analizy są ugięcia żelbetowej płyty fundamentowej przeciwpożarowego zbiornika na wodę o pojemności  $950 \text{ m}^3$  spoczywającego na siłownikach hydraulicznych. Zbiornik został posadowiony na gruncie nasypowym, wskutek czego uległ wychyleniu od pionu. W związku z tym, po wypompowaniu wody ze zbiornika, przeprowadzono rektyfikację obiektu polegającą na jego nierównomiernym podnoszeniu, wraz z fundamentem, za pomocą siłowników hydraulicznych. Siłowniki zostały zabudowane pod fundamentem na oparciach wykonanych ze stosów elementów betonowych wprowadzonych w grunt. Przeprowadzono obliczeniową analizę przemieszczeń oraz ugięć płyty spoczywającej na siłownikach. Zmiennymi parametrami modelu była liczba siłowników zabudowanych pod płytą oraz sztywność oparc siłowników na stosach.

Przemieszczenia płyty zbiornika spoczywającego na siłownikach wynikają z połączonych szeregowo sztywności siłownika, sztywności oparcia siłowników na stosach oraz ugięcia płyty, które jest miarą jej wyężenia. Maksymalne ugięcie płyty względem jej naroży zdefiniowano jako strzałkę ugięcia.

W przypadku, gdy liczba siłowników zabudowanych pod płytą wynosi 3, 4 i 8 wartość strzałki ugięcia nie zależy od sztywności oparcia. Wyznaczone w sposób obliczeniowy strzałki są równe odpowiednio 11,961 mm, 15,222 mm i 13,496 mm. Gdy liczba podpór jest większa od 8 wartość strzałki zależy od sztywności oparcia i maleje wraz ze zwiększaniem sztywności stosu. W przypadku liczby podpór wynoszącej 16 obliczona wartość strzałki wynosi od 11,451 mm, gdy sztywność oparcia jest nieskończona, do 11,907 mm w sytuacji, gdy sztywność ta wynosi 50 MN/m. W przypadku liczby podpór wynoszącej 32 wartości strzałek ugięć dla odpowiednich sztywności oparc wynoszą od 10,435 mm do 11,966 mm.

Na podstawie przeprowadzonych obliczeń została przeprowadzona rektyfikacja opróżnionego z wody zbiornika za pomocą 16 siłowników zabudowanych pod płytą, przy czym każdemu siłownikowi zapewniono sztywność oparcia wynoszącą 150 MN/m.