

Simulation study of flywheel energy storage assisted coal-fired unit frequency regulation

Shunyi SONG¹, Tianshu QIAO² , Rui ZHANG¹, Shuangyin LIANG², and Yibing Liu^{2*}

¹ Shenzhen Energy Nanjing Holding Co., Ltd, Nanjing, China

² School of Energy, Power and Mechanical Engineering, North China Electric Power University, Beijing, China

Abstract. With the increasing proportion of renewable energy power generation, its accompanying intermittency and volatility problems are becoming increasingly prominent, and the frequency fluctuation of the power system is becoming increasingly severe. Participation in frequency regulation services can be economically rewarding for generating units. The flywheel energy storage system can effectively improve the frequency regulation capability of coal-fired units. In this paper, the improvement of the FM capability of coal-fired units in the operation of a two-area interconnected power system containing wind power is investigated, and a model of a two-area interconnected power system comprising a turbine generator, wind power, and flywheel energy storage is established. The enhancement of the FM capability of coal-fired units by adding a flywheel energy storage system is analyzed. The simulation results show that adding the flywheel energy storage system improves the FM capability of the coal-fired unit to a considerable extent, and the coal-fired unit can decide the flywheel capacity it needs to be equipped with through detailed economic calculations.

Keywords: flywheel energy storage; coal-fired unit; frequency modulation characteristics.

1. INTRODUCTION

As the installed capacity and proportion of renewable energy power generation continue to increase, the intermittency and volatility of wind power and photovoltaics have led to continuous fluctuations in grid frequency, affecting the security of grid frequency [1, 2]. Among the related transaction contents of the electricity market, frequency adjustment/frequency modulation is an essential part of the ancillary services of the electricity market. This part of the frequency regulation service is mainly provided by fast-response energy storage equipment, such as the flywheel energy storage device in Stephentown, NY, or the gas turbine unit that can quickly start and stop [3, 4]. Generally speaking, coal-fired units with slow response speeds have poor frequency modulation capabilities and can only participate in frequency modulation to a limited extent and obtain less frequency modulation benefits.

The flywheel energy storage device has a fast response speed, high energy conversion rate, long life, and good frequency modulation performance. Meanwhile, its single-machine capacity is small, so its layout is flexible [5, 6]. Adding one or more flywheel devices to a coal-fired unit can effectively improve the overall frequency regulation performance of the unit, allowing it to undertake more frequency regulation tasks and obtain higher economic benefits. This paper establishes a mathematical model of the flywheel energy storage system and simulates the frequency regulation of the flywheel energy storage-assisted thermal power

unit on the MATLAB/Simulink platform. Research results show that adding flywheel energy storage can significantly improve the frequency regulation capability of thermal power units.

2. INTRODUCTION TO FLYWHEEL ENERGY STORAGE FOR POWER SYSTEM APPLICATIONS

Flywheel energy storage, as a type of mechanical energy storage, has a long history. It has been used in UPS, spacecraft attitude control, energy recovery, and other fields for decades. The application of flywheel energy storage equipment in power systems is relatively late. It was not associated with research and engineering practice until the early 21st century [7–10]. This situation is also due to changes in the energy mix. The increasing proportion of renewable energy power generation has made the frequency fluctuations of regional power grids more serious. It is necessary to improve the frequency regulation capability of the generator set to stabilize the grid frequency. This part of the task can be accomplished by rapid response units such as gas turbines or energy storage devices such as flywheel energy storage devices or battery devices. The advantages of the flywheel energy storage device include fast response speed, flexible action, re-response action that can be made within the time scale of milliseconds to seconds, and charging and discharging at maximum power; long service life, the service life of the main components can reach 25–30 years; High efficiency, the overall machine efficiency can get about 90%. High safety, serious accidents are less likely to occur in underground operations. The disadvantages of the flywheel energy storage device are low single-machine capacity and short operating time, requiring multiple devices to be put into use together to extend the

*e-mail: lyb@ncepu.edu.cn

Manuscript submitted 2024-05-22, revised 2024-08-05, initially accepted for publication 2024-08-26, published in November 2024.

working time. The current cost is still high, and the investment is significant. Two working modes of flywheel energy storage are derived based on the above characteristics. Firstly, flywheel energy storage of appropriate capacity is added to generating units, such as thermal power units or wind power units, to improve the overall frequency regulation capability of the units through coordinated operation with the generating units. Secondly, flywheel energy storage can function alone or in conjunction with other types of energy storage, such as electrochemical energy storage, to form an independent energy storage power station that can be integrated into the power grid to provide auxiliary services. Both working modes have corresponding engineering practices (references) and have achieved good results.

The structure of the flywheel energy storage unit used in this article is shown in Fig. 1, including the casing, rotor, bearings, bidirectional motor, control system, cooling system, and PCS system [11]. The rotor is the main component of the flywheel energy storage device to store energy, and the bidirectional motor runs coaxially with the rotor. The rotor runs at a fixed speed when there is no external load task. When receiving the charging command, the bidirectional motor acts as a motor to absorb excess electrical energy from the grid and convert it into mechanical energy of the rotor, and the rotor speed increases. When receiving a discharge command, the bidirectional motor acts as a generator, consuming the rotor machinery, outputting electrical energy, and reducing the rotor speed. Bearings are divided into transverse and longitudinal, which support the rotor, minimize friction, and ensure safety. The control system and cooling system work together to ensure the safe operation of the flywheel energy storage device. The casing isolates the above components from the external environment and evacuates them to keep the friction losses of the rotor at a low level. The PCS system is arranged separately to control the charging and discharging of the flywheel energy storage unit.

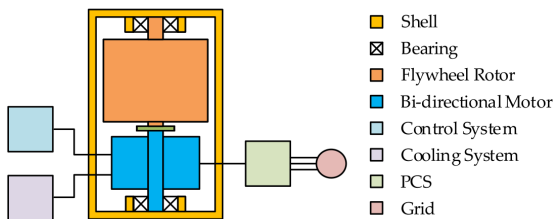

Fig. 1. Structure diagram of flywheel energy storage unit

3. MODELLING OF FLYWHEEL ENERGY STORAGE SYSTEMS

There are many ways to model FESS, which are mainly due to different research focus. Reference [12] proposed a simplified model containing several flywheels and studied its energy storage characteristics. However, the model is too simplified and does not consider the characteristics of the rotor and inverter separately. Reference [13] considered the effect of FESS assisting wind farms in frequency regulation, but its problem is that the mathematical model is too simple. Reference [14] studied a FESS charging and discharging control strategy based on HIM

and designed the control strategy of the machine-side converter and the grid-side converter. Since the motor used is HIM, the modelling idea is similar to that of this article, but the specific parts are different. Reference [15] modelled an array composed of single flywheel energy storage units, but its research focus was on the coordinated control part of the array. Reference [16] proposed a FESS control strategy with self-resistance to disturbance, but the research focus was also on self-resistance to disturbance, and the single-unit model was simplified a lot.

If only the links in FESS that have a greater impact on power response are considered, the flywheel energy storage unit can be described in terms of a rotor, a bi-directional motor (in this paper, we use permanent magnet synchronous motors, PMSM), and a PCS system (denoted by a machine-side converter and a grid-side converter [17]). Due to the smaller individual capacity and shorter charge/discharge action time, flywheel energy storage units are mainly operated as arrays of multiple units. There are two types of array arrangement: single-stage and two-stage. The single-stage and two-stage arrangements are shown in Figs. 2 and 3.

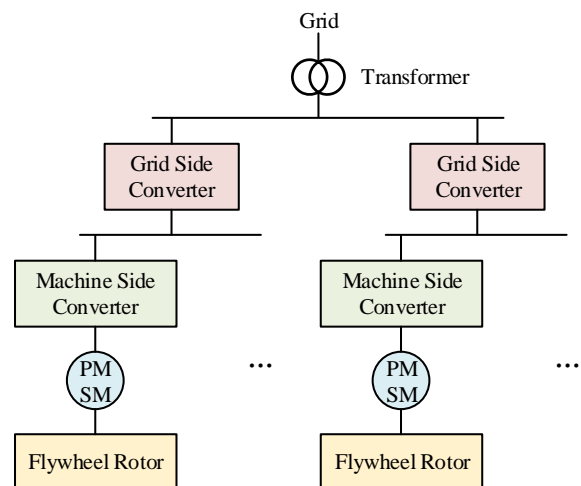

Fig. 2. Schematic diagram of a two-stage arrangement

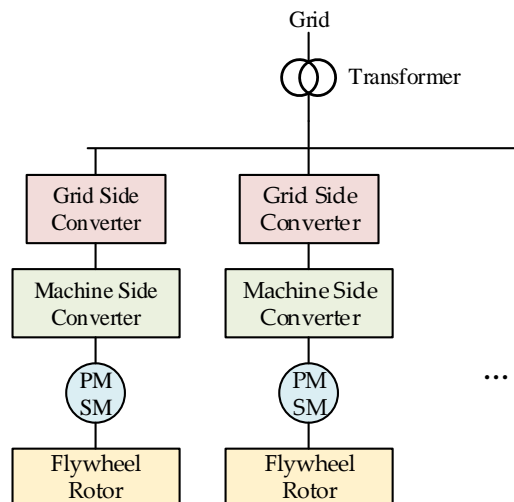

Fig. 3. Schematic diagram of single-stage arrangement

Simulation study of flywheel energy storage assisted coal-fired unit frequency regulation

The single-stage arrangement is characterized by high efficiency but low control accuracy. The two-stage arrangement is characterized by high control and precision but high losses. The two-stage arrangement is more widely used in practical engineering thanks to its advantages. This paper considers the role of flywheel energy storage in assisting thermal power unit frequency regulation. Preliminary research found that adding a lower-capacity flywheel (less than 5%) could effectively improve the frequency regulation capability of thermal power units, and the number of flywheel sets required was small so a single-stage arrangement could be used. Again, ignoring the differentiated characteristics of different units and approximating their load responses to be identical, an aggregated single-stage model can represent smaller-scale flywheel energy storage arrays. The schematic diagram of the regional power grid using the flywheel energy storage single machine aggregation model is shown in Fig. 4.

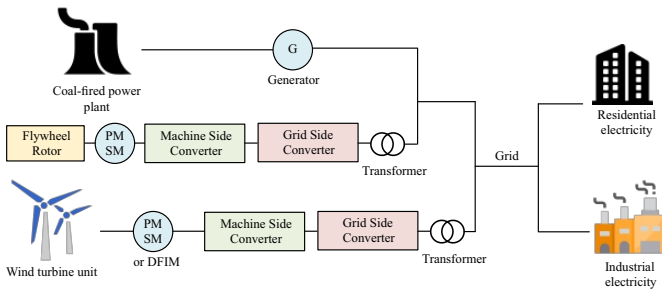

Fig. 4. Schematic diagram of regional power grid including FESS

As can be seen from Fig. 4, the machine-side converter, grid-side converter, and PMSM are the main components for simplifying the flywheel energy storage system. The flywheel energy storage system achieves the expected control goals by designing the control strategy of these components. Therefore, this article also uses these components as the main objects to model the flywheel energy storage system.

This article takes PMSM as the object and adopts the control strategy of D-axis current $i_d = 0$. Then the voltage equation, electromagnetic torque equation, and motion equation of the permanent magnet synchronous motor in the two-phase rotating coordinate system are shown in equations (1)–(3):

$$\begin{aligned} u_d &= -\omega_e L i_q, \\ u_q &= L \frac{di_q}{dt} + R_s i_q + \omega_e \psi_f, \end{aligned} \quad (1)$$

$$T_e = -\frac{3}{2} p \psi_f i_q, \quad (2)$$

$$J \frac{d\omega_m}{dt} = T_e - T_l - B \omega_m, \quad (3)$$

where u_d is the D-axis component of the motor voltage V ; u_q is the Q-axis component of the motor voltage V ; i_q is the motor stator current; L is the shaft synchronous inductance; R_s is the stator winding resistance; ψ_f is the rotor flux; ω_e is the rotor angular velocity; ω_m is the mechanical angular velocity of the

rotor; p is the number of rotor poles of the permanent magnet synchronous motor; B is the viscous friction coefficient of the motor; J is the moment of inertia of the motor rotor [18, 19].

3.1. Charging control strategy

The charging control goal of the flywheel energy storage system is to accelerate the flywheel rotor to the set speed. According to equations (1)–(3), the change in speed is controlled by the real-time electromagnetic torque. Since the stator current is proportional to the electromagnetic torque, the speed can be controlled by controlling the rotor current. Therefore, the machine-side converter adopts a dual closed-loop control strategy of speed inner loop and current outer loop. The speed controller obtains the current reference signal based on the deviation between the reference speed and the actual speed and then realizes the real-time speed tracking through the inner loop current control. The inner loop controller obtains the voltage reference signal according to the deviation between the current reference signal and the actual current and realizes real-time tracking of the current through the converter. The control principle diagram of the machine-side converter during the charging process is shown in Fig. 5.

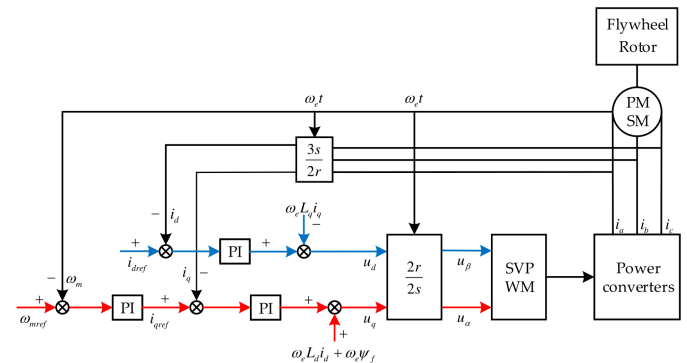

Fig. 5. Schematic diagram of the discharge condition of the machine-side converter

3.2. Discharge control strategy

When the FESS is discharging, the speed of the flywheel rotor is continuously reduced, which makes the speed of the generator rotor also continuously reduced. At this time, the electric energy emitted by the generator oscillates and becomes unstable. At this time, the machine-side converter and the grid-side converter need to work simultaneously to achieve stable electric energy output. The machine-side converter rectifies the unstable AC power into DC power, and the grid-side converter inverts the DC power into stable AC power for output and grid connection. Therefore, the machine-side converter adopts a dual closed-loop control strategy of power outer loop and current inner loop to control the output power of the generator; the grid-side converter adopts a dual closed-loop control strategy of DC bus voltage outer loop and current inner loop to control the DC bus voltage and ensure stable AC output. The control principle of the grid-side converter and the control principle diagram of the machine-side converter during the discharge process are shown in Figs. 6 and 7, respectively.

Simulation study of flywheel energy storage assisted coal-fired unit frequency regulation

To give full play to the superior frequency regulation performance of the flywheel energy storage system, the following load distribution rules are formulated: the load is allocated to the flywheel energy storage system first, and only when the flywheel energy storage system cannot bear it alone, the part of the load that cannot be borne will be allocated to the coal-fired unit.

4.1. Step disturbance simulation analysis

First, if wind power does not generate electricity, the overall frequency regulation capability of coal-fired units under step disturbance is considered separately. The simulation model is run and a step disturbance of size 0.05 p.u. is added to Area 1 at 100 s. The frequency response and tie line deviation of Area 1 are shown in Figs. 9 and 10.

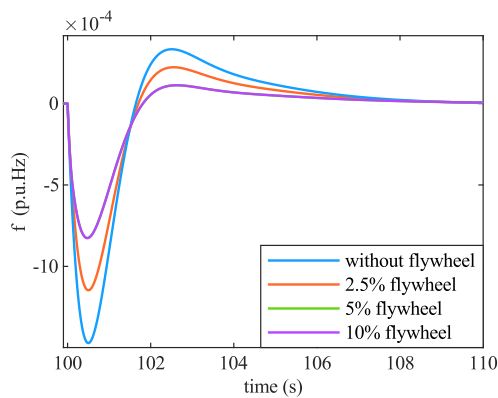

Fig. 9. Comparison chart of Area 1 frequency response

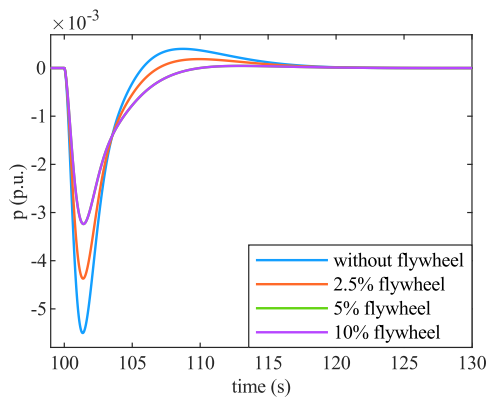

Fig. 10. Comparison chart of contact line deviation

Two conclusions can be drawn from Figs. 10 and 11: A) The addition of FESS can effectively improve the frequency regulation capability of coal-fired units. In Fig. 9, it is shown that the addition of FESS reduces the overall frequency fluctuation of the system. Adding 2.5% FESS can lessen the extreme value of the system frequency deviation from -1.47×10^{-3} p.u. Hz to -1.15×10^{-3} p.u. Hz, a decrease of 22%. At the same time, the extreme value of the tie line exchange power deviation can be reduced from -5.50×10^{-3} to -4.37×10^{-3} p.u., a 21% drop. B) For the most common load fluctuations (less than 0.05 p.u.), the larger the capacity of the FESS for auxiliary coal-fired unit

operation, the better. It can be seen from Figs. 9 and 10 that the line installed with 5% FESS completely overlaps with the line installed with 10% FESS, which proves that the installation of FESS with 5% capacity can already meet the load demand of the system to maintain frequency stability under this step disturbance.

4.2. Continuous disturbance simulation analysis

The previous section studied the response of the frequency regulation capability of coal-fired units under step disturbance. However, continuous, rapid, and frequent fluctuations are the situations that regional power grids face most. This load fluctuation is caused by the user's load fluctuation on the one hand and the fluctuation of the renewable energy power generation on the other hand. This paper assumes that only the output of the wind turbine on the power generation side fluctuates and uses continuous signals to simulate the output fluctuation of the wind turbine. The value range of the continuous signal is $[-0.025$ p.u., 0.025 p.u.], the maximum single load change does not exceed 0.05 p.u. Fig. 1, the signal changes once every 5 s, and changes 12 times a minute. Under continuous signal disturbance, the frequency response and tie line deviation of Area 1 are as follows: Figs. 11 and 12.

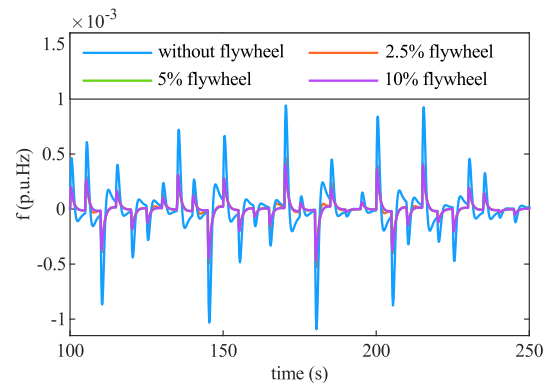

Fig. 11. Comparison chart of Area 1 frequency response

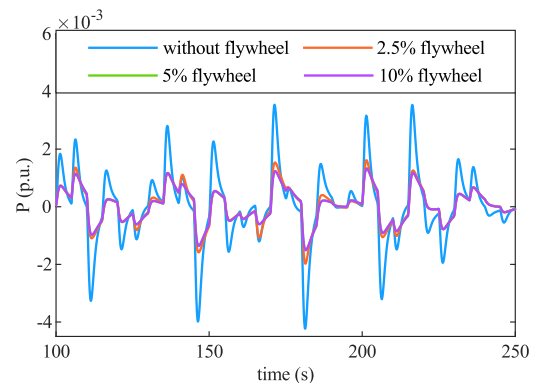

Fig. 12. Comparison chart of contact line deviation

According to Figs. 11 and 12, it can be seen that the improvement of the frequency regulation capability of coal-fired units under continuous disturbance is similar to that under step

disturbance. Two conclusions can be drawn: A) The response of flywheel energy storage to continuous disturbance is better. Under no-flywheel operating conditions, the frequency deviation of the system is 2.41×10^{-4} , and the power deviation is 1.17×10^{-3} . Under 2.5% flywheel operating conditions, these two indices are reduced by 46% and 46%, respectively. The performance of the 5% flywheel and 10% flywheel operating conditions is consistent, and these two parameters are reduced by 54% and 52%, respectively. B) There is almost no difference between installing a 5% flywheel and installing a 10% flywheel. Installing a 2.5% flywheel can significantly improve the frequency regulation capability of the unit. The improvement effect weakens when the capacity is further increased to 5%.

5. CONCLUSIONS

This paper discusses the feasibility of using a flywheel energy storage system to assist coal-fired units in frequency regulation operation under the condition of large-scale renewable energy grid connection and the impact of this operation mode on the grid frequency. This paper gives a detailed mathematical model of FESS. Based on this mathematical model, a linear model of flywheel energy storage-assisted thermal power frequency regulation is established in Matlab/Simulink, simulation experiments are conducted, and the following conclusions are drawn:

1. Flywheel energy storage has excellent frequency regulation performance and can operate on a time scale of milliseconds to seconds to adjust its own output. Due to this fast and accurate power regulation characteristic, FESS can quickly change its own output according to the frequency deviation of the power grid to adapt to the sudden change of the user-side load in the power grid, thereby contributing to the stability of the power grid frequency.
2. Adding FESS to coal-fired units can effectively improve the frequency regulation capability of coal-fired units. Compared with the condition without flywheel assistance, adding a 2.5% capacity flywheel can reduce the frequency deviation extreme value of step disturbance by 22% and the power deviation extreme value by 21%, and reduce the standard deviation of frequency deviation and power deviation of continuous disturbance by 46% and 46%, respectively. Adding a 5% capacity flywheel can reduce the frequency deviation extreme value of step disturbance by 44% and the power deviation extreme value by 41% and reduce the standard deviation of frequency deviation and power deviation of continuous disturbance by 54% and 52%, respectively. Increasing the flywheel capacity by 10% can reduce the frequency deviation extreme value of step disturbance by 44% and the power deviation extreme value by 41%; and reduce the standard deviation of frequency deviation and power deviation of continuous disturbance by 54% and 52%, respectively.
3. The simulation results show that under the most common small load disturbance in the power system, the frequency regulation capacity that can be improved by installing 5% FESS is basically the same as that by installing 10% FESS. Only when the load disturbance increases further, the FESS

with larger capacity can show its superiority. However, larger-scale load disturbances rarely occur. When such load disturbances occur, it means that the power system has a fault, so they can be ignored. Since the unit cost of FESS is high, it is necessary to carefully calculate the configuration capacity to find the optimal solution between the improvement level of frequency regulation capacity and the construction cost investment.

Authors' contributions

Conceptualization, S. Song; Methodology, S. Song; Software, T. Qiao; Validation, R. Zhang; Formal analysis, R. Zhang; Investigation, S. Song; Resources, S. Song; Data curation, S. Liang; Writing – original draft preparation, S. Song; Writing – review and editing, Y. Liu; Visualization, S. Liang. All authors have read and agreed to the published version of the manuscript.

REFERENCES

- [1] P. Komarnicki, "Energy storage systems: power grid and energy market use cases," *Arch. Electr. Eng.*, vol. 65, no. 3, pp. 495–511, 2016, doi: [10.1515/ae-2016-0036](https://doi.org/10.1515/ae-2016-0036).
- [2] X. Zhang *et al.*, "Overview and Prospect of Modern Power System Frequency Modulation on Power Supply Side in China," in *6th International Conference on Energy, Electrical and Power Engineering (CEEPE)*, 2023, pp. 861–866, doi: [10.1109/CEEPE58418.2023.10166170](https://doi.org/10.1109/CEEPE58418.2023.10166170).
- [3] M. Khoshjahan *et al.*, "Enhancing electricity market flexibility by deploying ancillary services for flexible ram," *Electr. Power Syst. Res.*, vol. 191, no. 2, p. 106878, 2021, doi: [10.1016/j.epr.2020.106878](https://doi.org/10.1016/j.epr.2020.106878).
- [4] S. Gülen, *Gas turbine combined cycle power plants*. Boca Raton: CRC, 2019, pp. 1–20, doi: [10.1201/9780429244360](https://doi.org/10.1201/9780429244360).
- [5] M. Baszyński and S. Piróg, "Determining the mechanical losses in a high-speed motor on the example of a flywheel energy storage system," *Arch. Electr. Eng.*, vol. 61, no. 3, pp. 299–313, 2012, doi: [10.2478/v10171-012-0024-0](https://doi.org/10.2478/v10171-012-0024-0).
- [6] A. Mystkowski and A. Rowiński, "Construction and control of AMBs high speed flywheel," *Arch. Mech. Eng.*, vol. 58, no. 1, pp. 79–89, 2011, doi: [10.2478/v10180-011-0005-7](https://doi.org/10.2478/v10180-011-0005-7).
- [7] M.E. Amiryar and K.R. Pullen, "A Review of Flywheel Energy Storage System Technologies and Their Applications," *Appl. Sci.*, vol. 7, no. 3, p. 286, 2017, doi: [10.3390/app7030286](https://doi.org/10.3390/app7030286).
- [8] B. Björn, H. Bernhoff, and M. Leijon, "Flywheel energy and power storage systems," *Renew. Sustain. Energy Rev.*, vol. 11, no. 2, pp. 235–258, 2007, doi: [10.1016/j.rser.2005.01.004](https://doi.org/10.1016/j.rser.2005.01.004).
- [9] F. Faramarz, A. Majazi, and K. Al-Haddad, "A comprehensive review of flywheel energy storage system technology," *Renew. Sustain. Energy Rev.*, vol. 67, pp. 477–490, 2017, doi: [10.1016/j.rser.2016.09.060](https://doi.org/10.1016/j.rser.2016.09.060).
- [10] J.G. Bitterly, "Flywheel technology: past, present, and 21st century projections," *IEEE Aerosp. Electron. Syst. Mag.*, vol. 13, no. 8, pp. 13–16, 1998, doi: [10.1109/62.707557](https://doi.org/10.1109/62.707557).
- [11] C. Subhashree, "Flywheel energy storage systems: A critical review on technologies, applications, and future prospects," *Int. Trans. Electr. Energy Syst.*, vol. 31, no. 9, p. e13024, 2021, doi: [10.1002/2050-7038.13024](https://doi.org/10.1002/2050-7038.13024).

Simulation study of flywheel energy storage assisted coal-fired unit frequency regulation

- [12] S. Wei *et al.*, “Analytical Models and Evaluation for Novel Multi-Stage Flywheel Configurations for Grid-Connected Wind Power Applications,” in *12th International Electrical Engineering Congress (iEECON)*, 2024, pp. 1–6, doi: [10.1109/iEECON60677.2024.10537905](https://doi.org/10.1109/iEECON60677.2024.10537905).
- [13] J. Du, G. Liu, and H. Yang, “Primary frequency control of flywheel energy storage assisted wind farms,” in *3rd New Energy and Energy Storage System Control Summit Forum (NEESSC)*, 2023, pp. 126–131, doi: [10.1109/NEESSC59976.2023.10349275](https://doi.org/10.1109/NEESSC59976.2023.10349275).
- [14] Y. Zhao *et al.*, “An Efficient Control Strategy for Integrated Flywheel Energy Storage System Based on HIM,” in *26th International Conference on Electrical Machines and Systems (ICEMS)*, 2023, pp. 2364–2368, doi: [10.1109/ICEMS59686.2023.10344949](https://doi.org/10.1109/ICEMS59686.2023.10344949).
- [15] X. Lyh, Y. Hu, and Z. Lin, “Distributed cooperative control of a flywheel array energy storage system,” *Int. J. Robust Nonlinear Control*, 2023, pp. 1–21, doi: [10.1002/rnc.6793](https://doi.org/10.1002/rnc.6793).
- [16] R. Sebastián and R. Peña-Alzola, “Control and simulation of a flywheel energy storage for a wind diesel power system,” *Int. J. Electr. Power Energy Syst.*, vol. 64, pp. 1049–2015, 2015, doi: [10.1016/j.ijepes.2014.08.017](https://doi.org/10.1016/j.ijepes.2014.08.017).
- [17] S.R. Das *et al.*, “Fuzzy Controller Designed Based Multilevel Inverter for Power Quality Enhancement,” *IEEE Trans. Consum. Electron.*, vol. 70, no. 2, pp. 4839–4847, 2024, doi: [10.1109/TCE.2024.3389687](https://doi.org/10.1109/TCE.2024.3389687).
- [18] E. Elhoussin *et al.*, “A Lab-scale Flywheel Energy Storage System: Control Strategy and Domestic Applications,” *Energies*, vol. 13, no. 3, p. 653, 2020, doi: [10.3390/en13030653](https://doi.org/10.3390/en13030653).
- [19] H.S. Saravia, H.P. Painemal, and M.M. Juan, “Flywheel Energy Storage Model, Control and Location for Improving Stability: The Chilean Case,” *IEEE Trans. Power Syst.*, vol. 32, no. 4, pp. 3111–3119, 2017, doi: [10.1109/tpwrs.2016.2624290](https://doi.org/10.1109/tpwrs.2016.2624290).
- [20] R. Qin *et al.*, “Simulation of Secondary Frequency Modulation Process of Wind Power with Auxiliary of Flywheel Energy Storage,” *Sustainability*, vol. 15, no. 15, p. 11832, 2023, doi: [10.3390/su151511832](https://doi.org/10.3390/su151511832).
- [21] Y. Lu *et al.*, “Optimal Design of Energy Storage System Assisted AGC Frequency Regulation Based on DDPG Algorithm,” in *IEEE International Conference on Power Science and Technology (ICPST)*, 2023, pp. 819–826, doi: [10.1109/ICPST56889.2023.10165606](https://doi.org/10.1109/ICPST56889.2023.10165606).