

Classification system from Optical Coherence Tomography using transfer learning

Muhamad Asvial, Tobias Ivandito Margogo Silalahi, and Muh. Asnoer Laagu

Abstract—This research aims to create a decision support system to identify retinal diseases using a four-class classification problem. To achieve this, the proposed system uses deep learning architecture to automatically recognize CNV, DME, and drusen from OCT images. The model employs two transfer learning architectures with several additional layers to classify retinal diseases. The purpose of model training, validation, and testing, the experiment uses 6,000 grayscale images labeled into four classes from the OCT data set. The Inception V3 model's proposed additional layer exhibits an increase in accuracy of 3.08% and a reduction in the loss by 0.3767. The experiment's results indicate that the Inception V3 model achieved an accuracy rate of 99.31%, and the VGG-16 model reached 98.83%, which outperformed other deep learning models using the OCT data set

Keywords—Deep Learning; Transfer Learning; Optical Coherence Tomography; Inception V3; VGG-16

I. INTRODUCTION

RETINAL disorders are among the leading causes of vision loss and blindness worldwide. Age Macular Degeneration (AMD) is one of the most common symptoms of Retinal Diseases, which will be suffered by 196 million people worldwide in 2020 [1]. The most common modern technique used to diagnose an early retinal disorder is Optical Coherence Tomography (OCT), performed 30 million times each year [2]. It is chosen because of its ability to provide a cross-sectional representation of the patient retina [3]. Usually, ophthalmologists spend ample time manually analyzing each cross-sectional representation of the patient's retina from OCT Images. This manual labour produced a significant workload for ophthalmologists, which resulted in a time-consuming analysis and increased the percentage of misdiagnosis [4]. Developing an automation method to help analyze OCT images for retinal diseases will increase the diagnosis efficiency. Deep learning methods provide features that are suitable to develop such automation.

Deep learning (DL) is an Artificial Intelligence technique that replicates human's neural networks to perform decision-making processes. Convolutional Neural Network (CNN) is a deep learning method that enables machines to learn and identify features from an image; the efficiency of this method increases deep learning usage to help experts analyze large quantities of medical images [5]. Traditionally, conventional CNN uses large amounts of data for model training to achieve high accuracy. Occasionally, the amount of available data is not sufficient to achieve high accuracy using conventional CNN. Transfer Learning is a Deep Learning method that uses previously trained

models on similar domains to provide information and improve efficiency on the current domain [6]. This allows for transfer learning models to be trained with a smaller dataset compared with conventional CNN models.

Proposed a deep learning model to classify normal retina or Age Macular Degeneration (AMD) retina using 2.6 million OCT images [7]. This model achieved a 93.45% accuracy with 92.64% and 93.69% sensitivity and specificity, respectively. Transfer Learning method using Alexnet was used in research [8] to classify normal retina with Diabetic Macular Degeneration (DME) from OCT images, which resulted in a 96% accuracy. Study compares a deep learning model that implements a capsule network to learn positional information from images with a deep learning model that uses the CNN network via transfer learning on classifying four classes of retinal diseases using 84,484 OCT images [9]. The model which uses a capsule network achieved a 99.6% accuracy compared to a transfer learning network which achieved 99.8% accuracy. provides a comparative study between the usage of three transfer learning models (LeNet, AlexNet and VGG-16) with an experiment of an additional dropout layer in the AlexNet model to diagnose retinal diseases in a four-classification problem using OCT images[10]. The proposed models were trained using a dataset that consists of 87,814 images from the Kaggle Dataset. This study achieved its highest accuracy in their VGG-16 model with 95.76% accuracy, followed by the AlexNet model without dropout layer, AlexNet model and LeNet with 93.1%, 92.28% and 83.76%, respectively. This study also shows the effect of dropout layers which cause a reduction of 0.0161 in the AlexNet model. [11] proposed the use of transfer learning models VGG-16 and Inception V3 models to detect three retinal diseases and one normal retina from OCT Images, which resulted in a 94% accuracy. Transfer learning model Inception V3 and Xception are used in [12] along with Categorical Hinge Loss as modification in their Support Vector Machine. Their Xception model achieved an overall accuracy of 98%, a sensitivity of 98% and a recall of 97.75%. On the other hand, their Inception V3 model produces an overall accuracy of 93%, a sensitivity of 93% and a recall of 92.5%.

The previously mentioned works achieved high accuracy on binary or multi-classification retinal diseases by using large amounts of OCT images. Our proposed model provides an alternative solution for retinal disease multi-classification problems using significantly fewer OCT images. This study proposed multi-classification deep learning models which can classify OCT images into the normal retina and three types of retinal diseases: Choroidal Neovascularization (CNV), Diabetic Macular Edema (DME) and Drusen. Rather than using CNN

The first and second Authors are with the University of Indonesia (e-mail: asvial@eng.ui.ac.id, tobias.silalahi@gmail.com).

The third Author is with the University of Jember (e-mail: asnoer@unej.ac.id)



directly for classification, our proposed models implement two different transfer learning models (Inception V3 and VGG-16).

Our primary contribution is the usage of transfer learning to develop an efficient model which has high accuracy at retinal diseases classification and is comparable with other models despite being trained on a limited dataset. Our benchmark dataset consists of 6000 OCT Images provided from Kaggle public dataset. Another contribution from this study is the implementation of added layers after implementing transfer learning on our proposed models. These layers consist of Convolutional Layer, MaxPooling Layer, Flatten Layer, Dropout Layer and Softmax Layer, which help to extract features and differentiate retinal diseases.

Our proposed model provides an accuracy of 99.31% for the Inception V3 model and 98.83% for the VGG-16 model. Furthermore, our proposed model has proved its advantages in terms of overall Accuracy, Sensitivity, Precision, Specificity, and F1-Score measurements compared with other states of the art models for retinal diseases classification.

The rest of this research paper is organized as follows. Section II provides the background for this study's main terminologies. In Section III, the proposed models which use Inception V3 and VGG-16 with additional layers will be illustrated. Experiment results, discussion and comparison with other related works are provided in Section IV. Section V provides this study conclusion and future work.

II. RELATED WORK

A. Retinal Diseases

Age Macular Degeneration (AMD) and Diabetic Retinopathy (DR) are among the two leading causes of retinal disorders, leading to visual impairment and blindness. In 2020, 196 million people suffered from AMD, which caused several retinal diseases [1]. AMD causes Drusen, which is an accumulation of fat present in the retina. Another retinal disease caused by AMD is CNV, a new blood vessel originating from a leaked retinal macular tissue. On the other hand, 21 million individuals suffered from DME, caused by DR affecting the macular retina region [13].

B. Optical Coherence Tomography (OCT)

OCT is a non-invasive imaging test that uses light waves to take cross-sectional images of a patient's retina. This allows OCT Images to visualize all retina layers, which can not be done in other eye examination methods such as fundus photography and dilated eye exams [3]. OCT Images of a normal retina does not show damage in the fovea or extra tissues between pigment and membrane, as well as hollow space in the choroid layer. Retinal Disorders such as damages, hollowness, and swollenness in the retina layer are signs of retinal diseases such as AMD and DME, which may lead to visual impairment and permanent vision loss. Examples of OCT Images for normal retina and damaged retina (CNE, DME, DRUSEN) are shown in Figure 1.

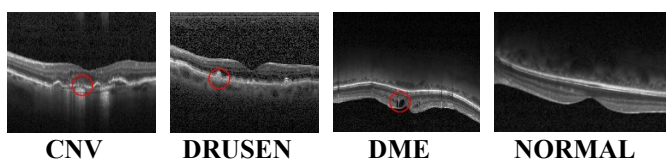

Fig. 1. Retinal Diseases OCT Images differentiate by circle region

C. Convolutional Neural Network (CNN)

CNN is a subset of deep learning methods which enable feature recognition and classification from images. CNN architecture uses neural networks in multiple layers to perform analysis from the input for a given output. It also implements convolution methods to extract features in the earlier layer from an input such as images. Complex features are extracted from the initial feature at the latter layers and calculated to provide a prediction.

D. Convolutional Layer

Convolutional Layers is the most prominent part of CNN. This layer extracts features from input by performing a convolution with it using each layer's filter matrices. Different filter matrices which perform convolution have a range of sizes depending on their layer specification, such as 3x3, 5x5, etc. The output is passed on as the input in the following layers: this allows further feature extractions in each Convolutional Layer as well as another adjustment in other different types of layers.

E. Pooling Layer, Dropout Layer and Fully Connected Layer

Pooling Layers reduces the size of the neural network by extracting the most prominent features from a given input and reducing the number of parameters [14]. The most used methods in Pooling layers are average pooling which takes the mean value, and max pooling, which takes the highest value from a window. This value is a substitute for all values in a window, which reduces the overall parameter size.

The dropout layer reduces overfitting by randomly deactivating neurons during the training processes. The Fully Connected Layer is the last layer of CNN architecture which is connected to all the neurons in the previous layers. These neurons' weights are calculated in the fully connected layer using the activation function to give a prediction [15].

F. Non-Linear Activation Function

Non-Linear activation functions are used in neural networks to calculate and adjust a deep learning model to a non-linear phenomenon in the given input [16]. Two of the non-linear activation functions used in this study are ReLu and Softmax. ReLu is an activation function in the hidden layer that normalizes negative values to zero to reduce computation. For prediction y , take x as input and choose the maximum value between 0 and x .

$$y = \max(0, x) \quad (1)$$

On the other hand, Softmax is an activation function in the fully connected layer that normalizes an input value into a probability in vector values. For each weight value (z_i), it will calculate its probability with the other weights by calculating its exponential value (e^{z_i}) and divided it with the sum of all exponential weight values e^{z_j} . This vector of values sums up to 1 and follows probability distribution [17].

$$\sigma(z)_i = \frac{e^{z_i}}{\sum_{j=1}^K e^{z_j}} \quad (2)$$

G. Transfer Learning

Transfer learning is a method to retrain several final layers of a given model with a new dataset to reduce the training time and size of the dataset. Transfer learning enables the creation of a new model using knowledge of a previously trained model by

training its final layers on a new dataset. This method reduces the amount of training dataset and training time to achieve a high classification accuracy on the new model. Inception V3 and VGG-16 are among the most popular models used for transfer learning. The primary features of both Inception V3 and VGG-16 are shown in Table I.

TABLE I
INCEPTION V3 AND VGG-16 PRIMARY FEATURES

Parameters	Inception V3 Model	VGG-16 Model
According to 1-Top Accuracy	0.941	91.90%
Input Shape	(None, 299, 299, 3)	(None, 224, 224, 3)
Number of Layers	48 Layers	16 Layers
Type of Pooling	Average Pooling	Max Pooling
Trainable Parameters	21,776,648	134260544
Non-Trainable Parameters	34,332	4,162,664
Total Parameters	21,810,980	138,423,208

III. PROPOSED CLASSIFICATION MODEL

A. Dataset

This study uses a benchmark dataset that contains 84,495 greyscale OCT Images divided into four classes CNV, DME, DRUSEN and NORMAL [18]. This dataset was obtained from research by [research dataset] available on the Kaggle platform. Due to class imbalance in the original dataset and an attempt to develop accurate models for multi-classification retinal diseases, our models were trained using a subset of the original dataset, which contained 4000 OCT Images for training, 2000 OCT Images for validation, and 1000 OCT for Images. Each dataset was divided equally into four classes to ensure a balanced class. Figure 2 shows a few samples of each class from the dataset.

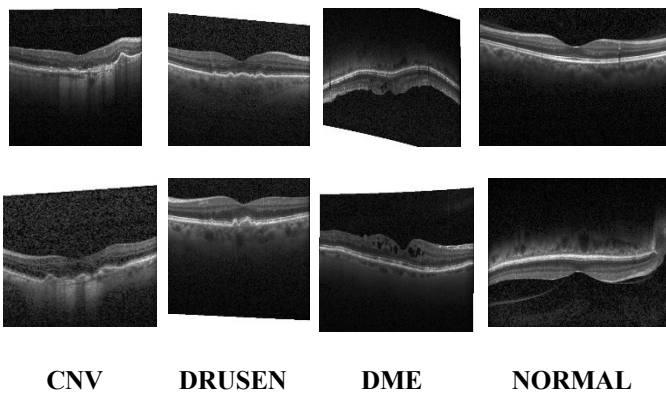

Fig. 2. CNV, DRUSEN, DME, NORMAL OCT Images sample from dataset

B. Proposed Model

This study proposed two models for retinal disease detection using two different types of transfer learning architecture, Inception V3 and VGG-16. Both transfer learning models and their respective weights were trained using the ImageNet dataset and obtained through Keras Library. Figure 3 shows the three primary phases of the proposed models' development process.

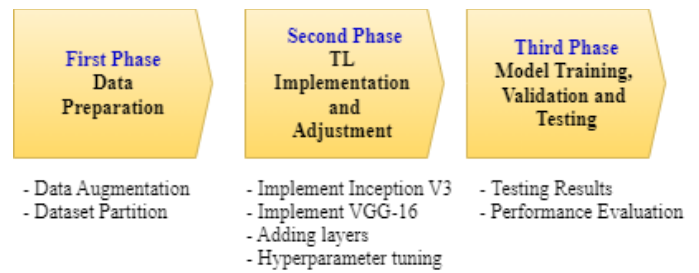

Fig. 3. Proposed model's development phases

1) Data Preparation

Each OCT Image in the dataset is resized into 150*150 pixels to adjust the model architecture input size. This study also implements several data augmentation techniques to each image to increase diversity in the dataset, such as width shift, height shift, shear, horizontal flip and rotation. This study also implemented randomly assigned rotation which ranges from 0-30 degrees, randomly assigned width shift which ranges from 0-25%, randomly assigned height shift which ranges from 0-25%, randomly assigned shear which ranges from 0-25%.

2) Transfer Learning Implementation and Adjustment

The proposed models implement the architecture and trained weight from Inception V3 and VGG-16. Models are trained on Kaggle Notebook, which compiled its program using GPU NVIDIA Tesla P100. Model architecture and weight of Inception V3 and VGG-16 are loaded from Keras Library. This study deactivated all of the upper Inception V3 layers, up until its mixed seven layers. On the other hand, all of the upper VGG-16 layers are frozen up until it's block5_pool_layer.

Both architectures are implemented into two different models, and their input layers are set to receive 150X150 RGB images. Adam optimizer is used for model compile with an adjustable learning rate. This study proposed adding five new layers on both models to increase their performance.

The first layer is a 3x3 convolution layer with 256 filters to extract additional features from the transfer learning model. The second Layer is a MaxPooling layer to reduce parameter size and computational resources. The third Layer is a flattened layer to convert the multiple dimension matrices into a one-dimensional matrix. The fourth layer is a dropout layer with a 20% dropout rate to reduce overfitting. The fifth layer is a fully connected layer using the Softmax activation function to classify the probability of each input into four output classes with a sum value of 1.

C. Training, Validation, and Testing

Training and validation processes use a total of 6000 OCT Images and are trained at 20 epochs. Model training uses 4500 OCT images with a batch size of 44, while model validation uses 1500 OCT images with a batch size of 11. Trained models achieve an accuracy of 99.31% for the Inception V3 model and 98.83% for the VGG-16 model. Table II illustrates the difference of parameters between Inception models v3 with the VGG-16 models. Figures 4 and 5 demonstrate the architecture of proposed CNN models using Inception V3 and VGG-16 architecture, respectively, with additional layers.

TABLE II
INCEPTION V3 AND VGG-16 PARAMETERS

Models	Trainable Parameter	Non-Trainable Parameter	Total Parameter
Inception V3	1189908	9569264	10759172
VGG-16	1189124	14714688	15903812

IV. PROPOSED CLASSIFICATION MODEL

This study shows that high accuracy is achievable for multi classification problems using transfer learning despite a limited training dataset. Both models are tested on Kaggle Notebook using a testing dataset that consists of 968 OCT Images [18]. Two confusion matrices are derived from testing results. This

experiment uses Accuracy, Precision, Sensitivity, Specificity and F1-Score to evaluate model performance from their respective confusion matrix.

A. Training and Validation Result

A comparison of training and validation results between this study's proposed models with models from the study [12], [19], [11] which use the same dataset. This comparison is shown in Table III. As illustrated in Table III, this study's Inception V3 model achieved the highest accuracy with 99.31% compared with the Inception V3 model proposed by with 93% [12]. On the other hand, this study VGG-16 proposed model managed to have higher accuracy with 98.83% compared to study [11], which also used VGG-16 architecture.

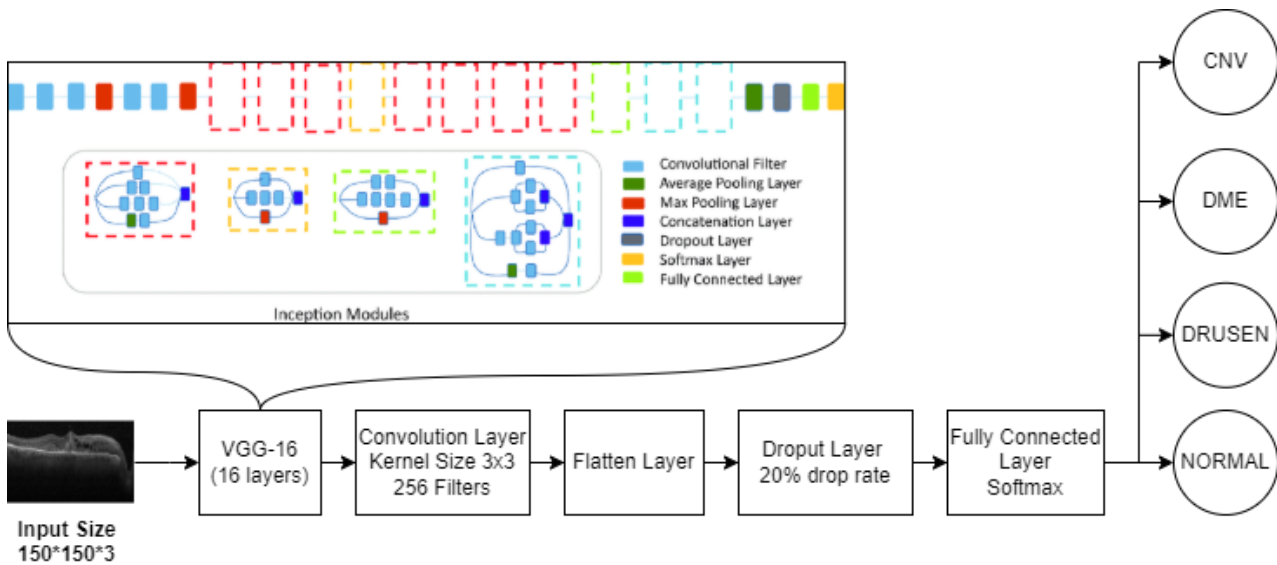

Fig. 4. The architecture of proposed model's development phases

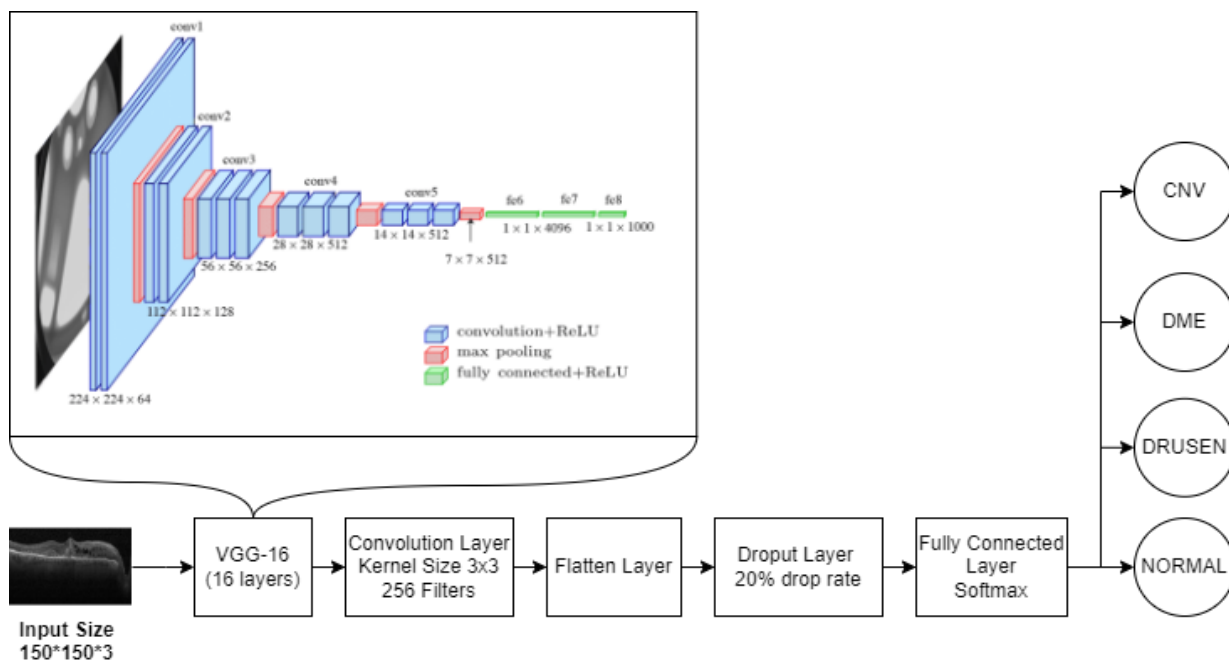

Fig. 5. The architecture of proposed model's development phases

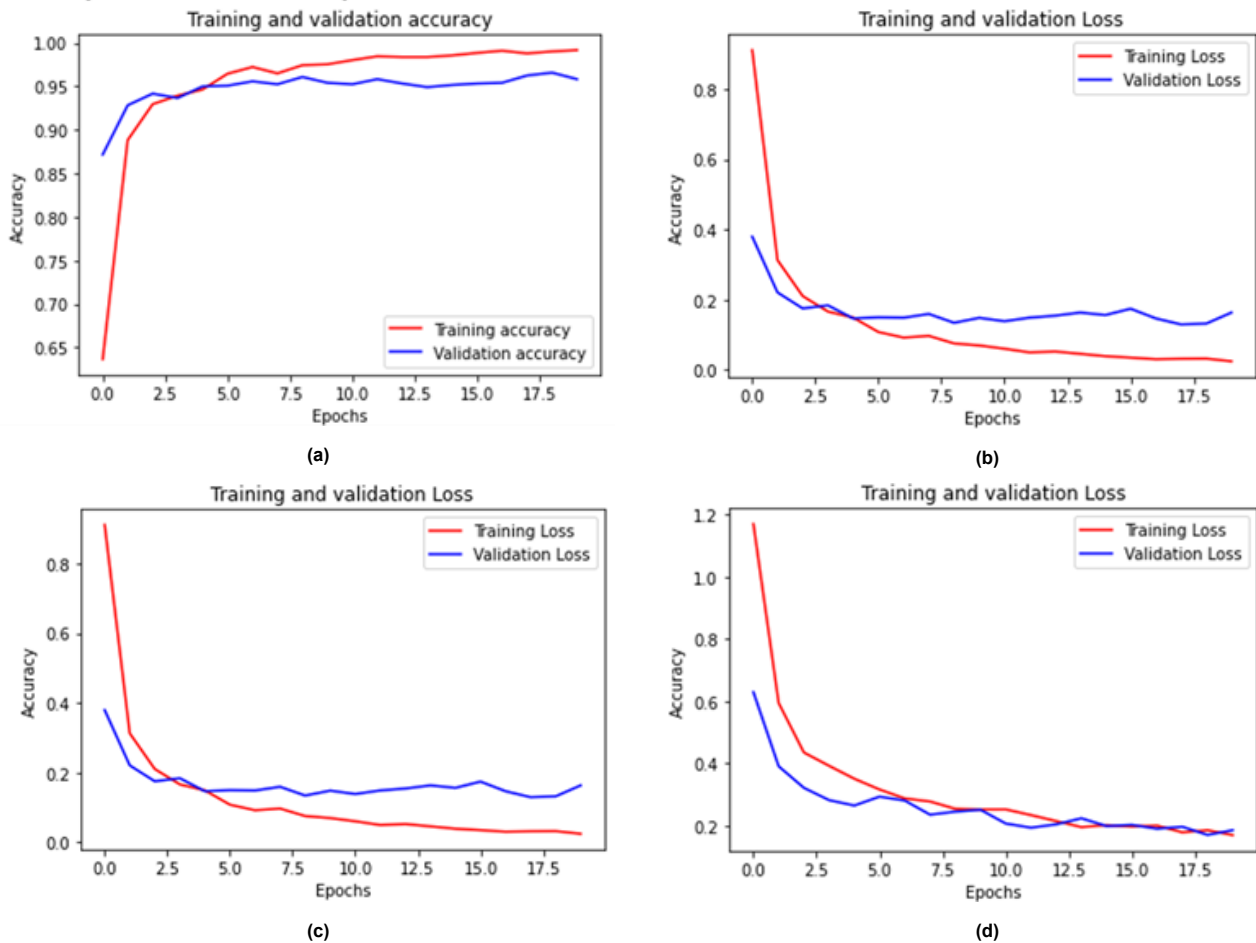

Fig. 6. The Proposed Inception V3 and VGG-16 model Training and Validation performance graph. (a) Inception V3 Accuracy; (b) Inception V3 Loss; (c) VGG-16 Accuracy; (d) VGG-16 Loss.

TABLE III
COMPARISON BETWEEN PROPOSED MODELS

Model	Train Dataset	Epochs	Accuracy %
CNN-based [Paper3-14]	80000	500	96.60%
Xception based [Paper3]	6000	100	98.00%
VGG-16 based [5]	4000	50	94.00%
VGG-16 (proposed model)	4500	20	98.83%
Inception V3 based [Paper 3]	6000	100	93.00%
Inception V3 (proposed model)	4500	20	99.31%

Both comparisons show that this study hyperparameters adjustment and additional layers on top of transfer learning architecture increase both model's performance. Additionally both [19] CNN model and [12] Xception models achieved an accuracy of 96.6% and 98% respectively.

Figure 6 shows accuracy and loss throughout the training and validation process for both proposed models in this study. As shown in figure 6, both models' training and validation accuracy increased significantly from their initial performance during the first five epochs and stabilized on the subsequent epochs with a slight difference between them. Meanwhile, both models' losses are decreasing throughout each epoch which shows an increase in model confidence in their prediction

Table VI shows several random images in every four classes, including both proposed Inception V3 and VGG-16 prediction on them. From the left side, the first column shows example images,

the second column shows the ground truth for each image, the third and fourth column represent Inception V3 and VGG-16 prediction respectively.

TABLE IV
PROPOSED INCEPTION V3 AND VGG-16 MODEL TRAINING AND VALIDATION PERFORMANCE GRAPH

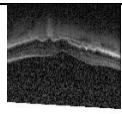
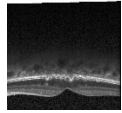
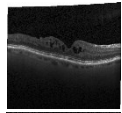
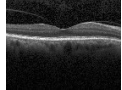
Image	Ground Truth	Inception V3	VGG-16
	CNV	CNV: 0.92 DRUSEN:0.02 DME: 0.06 NORMAL:0	CNV: 0.87 DRUSEN: 0.03 DME: 0.1 NORMAL: 0
	DRUSEN	DRUSEN: 0.89 DME: 0.03 NORMAL: 0.02	DRUSEN: 0.83 DME: 0.05 NORMAL: 0.02
	DME	DME: 0.99 NORMAL: 0 CNV: 0	DME: 0.96 NORMAL: 0 CNV: 0.02
	NORMAL	NORMAL:1 DRUSEN: 0 DME: 0	NORMAL: 1 DRUSEN: 0 DME: 0

B. Training and Validation Result

Testing results and performance metrics are represented in the confusion matrices in table V, table VI, table VII, table VIII, and table IX, respectively. These confusion metrics are testing results from this research's proposed models, [12] Inception V3 model and [11] VGG-16 models.

TABLE V
PROPOSED MODEL INCEPTION V3 CONFUSION MATRIX

Target Classes		Prediction Classes				Accuracy %
		CNV	DME	DRUSEN	NORMAL	
Target Classes	CNV	234	6	2	0	96.69%
	DME	4	236	0	2	97.52%
	DRUSEN	6	0	236	0	97.52%
	NORMAL	0	0	3	239	98.76%

TABLE VI
PROPOSED MODEL VGG-16 CONFUSION MATRIX

Target Classes		Prediction Classes				Accuracy %
		CNV	DME	DRUSEN	NORMAL	
Target Classes	CNV	228	8	6	0	94.21%
	DME	5	223	2	12	92.15%
	DRUSEN	26	3	212	1	87.60%
	NORMAL	0	1	2	239	98.76%

TABLE VII
INCEPTION V3 CONFUSION MATRIX

Target Classes		Prediction Classes				Accuracy %
		CNV	DME	DRUSEN	NORMAL	
Target Classes	CNV	200	39	11	0	80.00%
	DME	1	240	2	7	96.00%
	DRUSEN	6	3	240	0	96.39%
	NORMAL	0	4	1	245	98.00%

TABLE VIII
VGG-16 CONFUSION MATRIX

Target Classes		Prediction Classes				Accuracy %
		CNV	DME	DRUSEN	NORMAL	
Target Classes	CNV	182	3	6	1	94.79%
	DME	5	202	2	6	93.95%
	DRUSEN	3	5	177	12	89.85%
	NORMAL	9	5	6	187	90.34%

Table V until table VIII shows that the proposed Inception V3 model gives the highest accuracy for every four classes (CNV, DME, DRUSEN, NORMAL) with the accuracy of 96.69%, 97.52%, 97.52%, and 98.76%, respectively.

Table IX shows a comparison between the proposed Inception V3 and VGG-16 model compared with [12] Inception V3 model and [11] VGG-16 model using performance metric (Precision, Sensitivity, F1-Score). The column named Data in Table IV represents the amount of OCT images used in each class for testing each model.

Table IX can be seen that the proposed Inception V3 model achieved higher scores on all performance metrics for each retinal disease class compared with the Inception V3 model from [12] except for precision metric on class CNV. On the other hand, the proposed VGG-16 achieved better results on all

performance metrics for each class compared with the VGG-16 model from [11] except for precision metric on class DRUSEN and sensitivity metric on class CNV and normal.

TABLE IX
PERFORMANCE METRICS COMPARISSION BETWEEN PROPOSED MODELS AND OTHER RELATED MODELS

Model	Classes	Precision	Sensitivity	F-Score	Data
Inception V3 [12]	CNV	0.97	0.80	0.88	250
	DME	0.84	0.96	0.90	250
	DRUSEN	0.94	0.96	0.95	250
	NORMAL	0.97	0.98	0.97	250
Inception V3 proposed model	CNV	0.96	0.97	0.96	242
	DME	0.96	0.98	0.98	242
	DRUSEN	0.98	0.98	0.98	242
	NORMAL	0.99	0.99	0.99	242
VGG-16 [11]	CNV	0.91	0.95	0.93	42
	DME	1.00	0.81	0.89	250
	DRUSEN	0.93	0.90	0.92	250
	NORMAL	0.86	1.00	0.92	42
VGG-16 proposed model	CNV	0.88	0.94	0.91	242
	DME	0.95	0.92	0.94	242
	DRUSEN	0.96	0.88	0.92	242
	NORMAL	0.95	0.99	0.97	242
Xception [12]	CNV	0.97	0.95	0.96	250
	DME	0.97	0.96	0.98	250
	DRUSEN	0.98	0.97	0.97	250
	NORMAL	1.00	1.00	1.0	250

C. Analysis and Discussion

Based on all the performance metrics that are used to evaluate model performance, both proposed models show high results in terms of Accuracy, Precision, Sensitivity and F1-Score. These results are comparable and almost surpassed other proposed models from [12] and [11] in every parameter metric despite using fewer training data. Our proposed Inception V3 model achieved a higher score in almost every performance metric compared to [12] Inception V3 model. Similar situations can be observed from our VGG-16 model results compared with [11] VGG-16 models.

These results demonstrated that an adjustment on the original transfer learning architecture, such as the number of deactivated layers and hyperparameter tuning, would improve model performance. Furthermore, an implementation of added layers will improve model performance despite using the same transfer learning architecture. Proposing the use of convolution layers offers an additional feature extraction that helps model classification. Additional dropout layers reduce losses and improve accuracy because it decreases the likelihood of model memorization from the training dataset.

V. CONCLUSION

Two deep learning models for retinal diseases decision support systems are developed using transfer learning architecture Inception V3 and VGG-16. These models classify OCT images into four classes (CNV, DME, DRUSEN, NORMAL). The proposed models proved that 4500 images for model training are sufficient to achieve high performance. Both models achieved

higher accuracy than other deep learning models despite using the same transfer learning architecture and fewer training data. The proposed Inception V3 model produces better performance in terms of Precision, Sensitivity, F1-Score when tested using the benchmark testing dataset compared with other models.

These results show that adding several layers to adjust the transfer learning model, such as a convolutional layer, pooling layer. Dropout layer and hyperparameter tuning, such as the Softmax activation function, improve model performance on detecting features for each retinal disease.

In the future, a higher performance transfer learning architecture can be implemented to improve model performance. Segmentation method can also be used to reduce computational resources by focusing on certain features on a given window rather than parsing each pixel with convolution method.

REFERENCES

- [1] W. L. Wong *et al.*, “Global prevalence of age-related macular degeneration and disease burden projection for 2020 and 2040 : a systematic review and meta-analysis,” *Lancet Glob. Heal.*, vol. 2, no. 2, pp. e106–e116, 2020.
- [2] E. A. Swanson and J. G. Fujimoto, “The ecosystem that powered the translation of OCT from fundamental research to clinical and commercial impact [Invited],” *Biomed. Opt. Express*, vol. 8, no. 3, p. 1638, 2017.
- [3] N. Ferrara, “Vascular endothelial growth factor and age-related macular degeneration: From basic science to therapy,” *Nat. Med.*, vol. 16, no. 10, pp. 1107–1111, 2010.
- [4] M. R. Hee *et al.*, “Optical Coherence Tomography of the Human Retina,” *Arch. Ophthalmol.*, vol. 113, no. 3, pp. 325–332, 1995.
- [5] Y. LeCun, L. Bottou, Y. Bengio, and P. Haffner, “Gradient-based learning applied to document recognition,” *Proc. IEEE*, vol. 86, no. 11, pp. 2278–2323, 1998. <https://doi.org/10.1109/5.726791>
- [6] M. Asvial and M. A. Laagu, “New Development of Physarum Routing Algorithm with Adaptive Power Control,” *IEEE Access*, vol. 9, pp. 74868–74878, 2021. <https://doi.org/10.1109/ACCESS.2021.3065036>
- [7] C. S. Lee, D. M. Baughman, and A. Y. Lee, “Deep Learning Is Effective for Classifying Normal versus Age-Related Macular Degeneration OCT Images,” *Ophthalmol. Retin.*, vol. 1, no. 4, pp. 322–327, Jul. 2017.
- [8] G. C. Y. Chan, A. Muhammad, S. A. A. Shah, T. B. Tang, C. K. Lu, and F. Meriaudeau, “Transfer learning for Diabetic Macular Edema (DME) detection on Optical Coherence Tomography (OCT) images,” in *Proceedings of the 2017 IEEE International Conference on Signal and Image Processing Applications, ICSIPA 2017*, 2017, pp. 493–496. <https://doi.org/10.1109/ICSIPA.2017.8120662>
- [9] T. Tsuji *et al.*, “Classification of optical coherence tomography images using a capsule network,” *BMC Ophthalmol.*, vol. 20, no. 1, pp. 1–9, Mar. 2020.
- [10] M. A. Laagu and M. Asvial, “The Physarum Algorithm with Adaptive Power Control: A Routing Optimization to Overcome Obstacle Problems in IoT Network,” *IOP Conf. Ser. Mater. Sci. Eng.*, vol. 1077, no. 1, p. 012054, 2021.
- [11] A. Bhowmik, S. Kumar, and N. Bhat, “Eye disease prediction from optical coherence tomography images with transfer learning,” *Commun. Comput. Inf. Sci.*, vol. 1000, pp. 104–114, 2019.
- [12] A. Adel, M. M. Soliman, N. E. M. Khalifa, and K. Mostafa, “Automatic Classification of Retinal Eye Diseases from Optical Coherence Tomography using Transfer Learning,” *16th Int. Comput. Eng. Conf. ICENCO 2020*, pp. 37–42, Dec. 2020.
- [13] A. Sancho, S. Johnen, S. Recalde, N. Gama, G. Thumann, and J. Groll, “Current Treatment Limitations in Age-Related Macular Degeneration and Future Approaches Based on Cell Therapy and Tissue Engineering,” vol. 2014, 2020.
- [14] H. Gu, Y. Wang, S. Hong, and G. Gui, “Blind channel identification aided generalized automatic modulation recognition based on deep learning,” *IEEE Access*, vol. 7, pp. 110722–110729, 2019. <https://doi.org/10.1109/ACCESS.2019.2934354>
- [15] Y. Bengio, *Learning deep architectures for AI*, vol. 2, no. 1, 2009.
- [16] L. Breiman, “Statistical modeling: The two cultures,” *Stat. Sci.*, vol. 16, no. 3, pp. 199–215, 2001.
- [17] S. Sakib, Ahmed, A. Jawad, J. Kabir, and H. Ahmed, “An Overview of Convolutional Neural Network: Its Architecture and Applications,” *ResearchGate*, no. November, 2018. <https://doi.org/10.20944/preprints201811.0546.v1>
- [18] “Retinal OCT Images (optical coherence tomography) | Kaggle.”
- [19] M. Treder, J. L. Laueremann, and N. Eter, “Automated detection of exudative age-related macular degeneration in spectral domain optical coherence tomography using deep learning,” *Graefes Arch. Clin. Exp. Ophthalmol.*, vol. 256, no. 2, pp. 259–265, Feb. 2018.