



© 2024. The Author(s). This is an open-access article distributed under the terms of the Creative Commons Attribution-ShareAlike 4.0 International Public License (CC BY SA 4.0, <https://creativecommons.org/licenses/by-sa/4.0/legalcode>), which permits use, distribution, and reproduction in any medium, provided that the article is properly cited.

Removal of microplastics by electrocoagulation

Alex Pilco-Nuñez^{1*}, Edilberto Hinojosa-Antonio², Pablo Diaz-Bravo²,
Wendy Palacios-Salvador³, Richard Solis-Toledo³, Jhanover Baldeon-Romero³

¹Universidad Nacional de Ingeniería, Lima, Peru

²Universidad Nacional del Callao, Peru

³Universidad de Huánuco, Peru

* Corresponding author's e-mail: apilco@uni.edu.pe

Keywords: aluminum, iron, microplastics, electrocoagulation, synthetic wastewater

Abstract: With the gradual increase of microplastics in water bodies, it is essential to understand the current treatment processes for their removal. This study aims to investigate the removal of microplastics in synthetic solution by electrocoagulation (EC). The effects of electrode type, contact time (min), agitation speed (rpm) and current density (A/m²) were evaluated using a fractional factorial design. The results showed that the aluminum anode achieved a higher removal of microplastics than the iron anode, reaching 98.04% removal with the aluminum operational configuration within 15 min at 70 rpm and a current density of 20 A/m². A high correlation between the predicted and observed removal was evidenced, with values of $R^2=0.99$ and adjusted $R^2=0.98$, indicating a good agreement between the model and the experimental data, confirming the validity and feasibility of the adopted linear model. This study demonstrates that the electrocoagulation process has a great potential for the removal of microplastics.

Introduction

Microplastic pollution in aquatic ecosystems is a global environmental problem caused by the uncontrolled use of plastics over recent decades (Shen, et al., 2022). Microplastics are small particles that originate from the fragmentation and degradation of plastic resulting from microbial activity and exposure to environmental factors such as water, solar radiation and wind (Barnes, et al., 2009). Microplastic fragments are stable in aquatic environments and can remain there for thousands of years (Cózar, et al., 2014). The presence of microplastics poses significant risks to both aquatic ecosystems and human health, given that they can enter the food chain through the consumption of contaminated water or food (Lambert and Wagner, 2016).

Microplastics have a high capacity to adsorb organic chemical contaminants, heavy metals and harmful bacteria due to their high specific surface area, persistence and fluidity, which amplifies their impact on the environment and human health (Antunes, et al., 2013). Their chemical properties, such as strength, durability, particle size and hydrophobic characteristics, enhance their hazardousness (Bhatt, et al., 2021). The lightness and small size of microplastics facilitate their ingestion by aquatic organisms leading to abrasion, intestinal obstruction, and mortality in aquatic fauna (Slootmaekers, et al., 2019). In addition, toxic chemicals adsorbed onto microplastics can severely harm aquatic organisms and transfer

to humans through the food chain, posing serious public health risks (Shen, et al., 2022). Recently, Dutch scientists detected microplastics in human blood, indicating that microplastics may infiltrate human organs (Leslie, et al., 2022).

Current studies on microplastics mainly focus on their sorption state, detection methods (Huang, et al., 2021), ecotoxicology (Dong, et al., 2020), and distribution (Andrady, 2011), but research on their removal from aquatic environments remains limited (Hu, et al., 2023). Ensuring water safety and quality requires exploring effective methods for microplastic removal. In recent years, various treatment methods have been investigated for removing microplastic, such as coagulation (Ma, et al., 2019), filtration (Bannick, et al., 2019), membrane separation (Malankowska, et al., 2021), magnetic extraction (Grbic, et al., 2019), photocatalysis (Ebrahimbabaie, et al., 2022), and conventional activated sludge (Liu, et al 2019). Electrocoagulation is a process where a metal electrode, typically aluminum or iron, undergoes electrochemical dissolution. The resulting metal ions react with hydroxide ions to form metal hydroxide coagulants (Holt, et al., 2005). These coagulants facilitate floc formation by neutralizing suspended colloidal particles and adsorbing dissolved contaminants (Khandegar, and Saroha, 2013). EC offers a simple, fast and cost-effective method for wastewater treatment without the addition of chemicals (Zailani, and Zin, 2018).

In relation to microplastic removal, previous studies have shown that EC has demonstrated the ability to remove

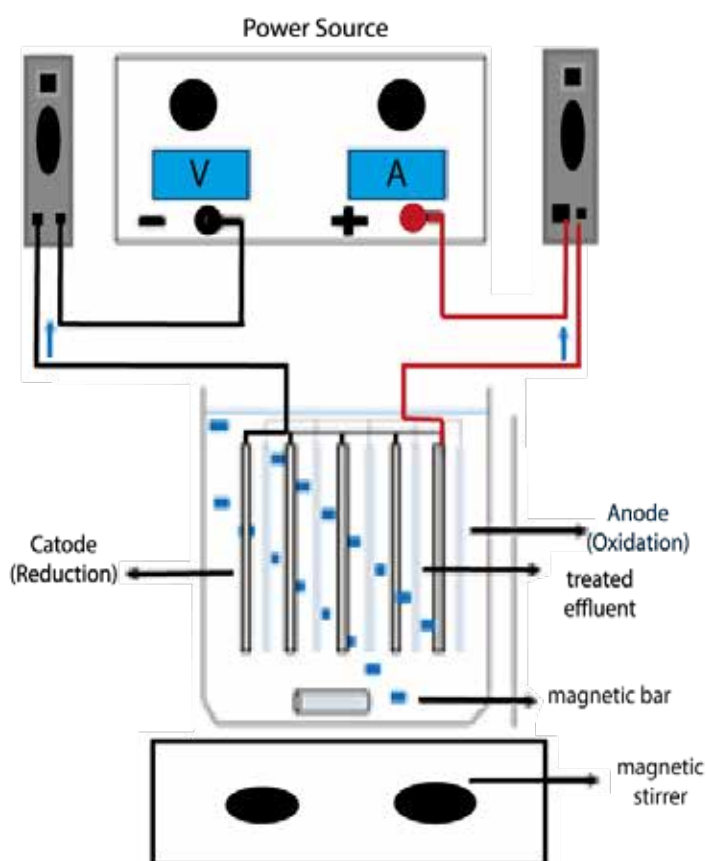

Figure 1. Diagram of the electrocoagulation system

polyethylene microbeads with efficiencies of 99% (Perren, et al., 2018), 98.6 % (Elkhatib, et al., 2021), 98.7 % (Shen, et al., 2022) and 97.5% (Xu, et al., 2022). Given its good performance, EC shows great potential for removing microplastics from wastewater, however, studies in synthetic waters are necessary to better control the influence of various factors. Therefore, the main objective of this study was to evaluate the performance of EC in removing microplastics in synthetic solution. The EC system's performance was evaluated using key operating parameters, including electrode type, contact time, agitation speed, and current density to determine the best conditions for microplastic removal.

Materials and methods

Materials

Aqueous solutions were prepared by dissolving 255 mg of polyethylene (PE) microspheres (average particle size of 300-355 μm) in one liter of double-distilled water. Due to the hydrophobic nature of the microspheres, the solution was homogenized to ensure even dispersion. The microspheres, procured from Cospheric (<https://www.cospheric.com/>), were used for the experiments. Electrocoagulation experiments were conducted in a 1-liter batch reactor equipped with two iron and two aluminum electrodes (80 mm \times 85 mm, 98.5% purity), configured as cathodes and anodes. The electrodes were connected to a TAIDOX DC power supply (0-30 V and 0-5 A). To maintain uniform mixing, an INTLLAB MS-500 magnetic stirrer (0-3000 rpm) was used.

Method

Before each experiment, the electrodes were cleaned with sandpaper, immersed in HNO_3 solution, and then rinsed with distilled water. For each trial, 1 liter-solution containing 255 mg/L of microplastics was prepared. The experimental setup of electrocoagulation is shown in Fig. 1. At the end of each experiment, stirring and DC power supply were turned off. Residual microplastics were measured using the SMEWW-APHA-AWWA-WEF Part 2540 D method (23rd edition of 2017) for Total Suspended Solids (TSSmicro). From the final sample, 20 mL were immediately filtered using a 0.45 μm Whatman filter. Each experiment was performed in duplicate. Filters were dried at 40 $^\circ\text{C}$ for 24 h and the mass of residual microplastic fragments was measured. The removal efficiency (%) was calculated using the following equation:

$$\text{removal} = \frac{m_i - m_f}{m_i} \times 100 \quad (1)$$

Where:

- m_i : Initial mass of microplastics in solution (mg).
- m_f : Residual mass of microplastics (mg)

Experimental Design

The experimental scheme used to select the important variables of the process was a fractional factorial design. A factorial model is composed of a list of coefficients multiplied by the associated factor. In a 2^{k-1} fractional factorial experimental design, the k factors vary at two levels. Therefore, the total number of trials (N) is given as:

Table 1. Factors and levels of the fractional factorial experimental design

Item	Factors	Levels	
		-1(Low)	+1(High)
A	Electrode type	Iron	Aluminum
B	Contact time (min)	10	15
C	Stirring speed (rpm)	70	150
D	Current density (A/m ²)	20	70

$$N = r \times 2^{k-1} + C \quad (2)$$

Where:

k: Combination of factors.

r: Number of replicates

C: represents the number of center point measurements used to test the quadratic terms in the low and high range. The center points are used to estimate the pure error and curvature in the model, the mathematical form of the model is presented in equation 3.

$$y = b_0 + \sum_{i=1}^n b_i X_i + \sum_{1 \leq i < j}^n b_{ij} X_{ij} \quad (3)$$

Where:

y: response factor

b_0, β_i, β_{ij} : unknown parameters

X_i, X_j, X_{ij} : study factors.

In this study, the influence of four main factors was investigated: electrode type (A), contact time (B), stirring speed (C), and current density (D). Microplastic removal was selected as the dependent variable (response). Table 1 shows the four parameters and their levels used in the experiments. The factor levels were coded as -1 (low), 0 (midpoint) and +1 (high). A total of sixteen experiments were conducted.

The effects of the factors were compared, and significant statistical differences were identified using a factorial design, with ANOVA used for data analysis and interpretation (Gutiérrez and Salazar, 2012). Model validation was performed through an acceptability analysis, where the evaluation depended on the *F-value* and the *p-value*. The model fit was assessed using R^2 , adjusted R^2 , and predictive R^2 values. Statistical analyses were conducted using Desing Expert v11 software.

Results and discussion

Removal of microplastics

Table 2 shows the matrix configuration of the fractional factorial design and the corresponding results of the studied response. The table indicates that the response varied significantly within the experimental domain. The highest microplastic removal achieved was 98.04%, using the operational configuration of aluminum, a contact time of 15 min, and agitation speed of 70 rpm, and a current density of 20 (A/m²). This result is remarkably efficient when compared to other similar studies, as discussed below.

In previous studies (see Table 3), polyethylene (PE) microspheres were removed using aluminum and copper electrodes, achieving a removal efficiency of 98.7% with a contact time of 6 hours and an agitation speed of 150 rpm (Shen,

Table 2. Removal of microplastics by electrocoagulation using the fractional factorial design

Treatments	Experimental runs	Electrode type	Time (min)	Speed (rpm)	Current density (A/m ²)	TSS (mg/L)	Microplastics removal (%)
T0	0	–	0	0	0	255.0	0.00
T1	1	Iron	10	70	20	46.2	81.88
	9	Iron	10	70	20	41.1	83.88
T2	2	Aluminum	10	70	70	38.3	84.98
	10	Aluminum	10	70	70	35.5	86.08
T3	3	Iron	15	70	70	29.6	88.39
	11	Iron	15	70	70	34.2	86.59
T4	4	Aluminum	15	70	20	5.0	98.04
	12	Aluminum	15	70	20	5.6	97.80
T5	5	Iron	10	150	70	67.3	73.61
	13	Iron	10	150	70	71.9	71.80
T6	6	Aluminum	10	150	20	31.0	87.84
	14	Aluminum	10	150	20	26.4	89.65
T7	7	Iron	15	150	20	32.3	87.33
	15	Iron	15	150	20	38.7	84.82
T8	8	Aluminum	15	150	70	19.8	92.24
	16	Aluminum	15	150	70	22.0	91.37

et al., 2022). In comparison, the present study achieved a similar removal significantly shorter time (15 min), highlighting the effectiveness and efficiency of the electrocoagulation process and operational configuration.

Another study reported a removal efficiency of 99% for PE microspheres using aluminum electrodes, with an agitation time of 1 hour at 60 rpm and a current density of 15 mA/cm² (Perren, et al., 2018). While this result is slightly higher, the required agitation time was four times longer than that in the present study. This suggests that the combination of a shorter agitation time and a higher current density of 20 A/m² may enhance the efficiency of the process.

Additional studies have shown 98.6% removal for PE microplastics using aluminum electrodes, with an agitation time of 1.5 hours at 60 rpm and a current density of 8.07 mA/cm² (Elkhatib, et al., 2021). However, the agitation time required in these studies was longer than the 15 min used in the present study, emphasizing the efficiency of the shorter agitation time achieved here. High removal efficiencies were also observed for other types of microplastics. For example, polymethylmethacrylate (PMMA) microplastics achieved 99.1% removal using aluminum and copper electrodes, with 6 hours of agitation at 150 rpm (Shen, et al., 2022). In comparison, the present study achieved similarly high removal with a much shorter agitation time.

For cellulose acetate (CA) microplastics, the removal reached 99.9% using aluminum and copper electrodes, with

6 hours of agitation at 150 rpm (Shen, et al., 2022). Despite the high removal, the agitation time required was considerably longer than in the present study. Likewise, polypropylene (PP) microplastics also reached 99.9% efficiency under comparable conditions (Shen, et al., 2022), but again with a much longer agitation time.

Interestingly, studies using iron electrodes generally reported lower microplastic removals. For example, PMMA microplastics with iron electrodes achieved an efficiency of 69.5% with 6 hours of agitation at 150 rpm (Shen, et al., 2022), which is significantly lower than the removal achieved with aluminum electrodes in the present study. This reinforces the choice of aluminum as the preferred electrode material for microplastic removal.

Finally, studies using similar operational conditions, such as PE and PVC microplastics with aluminum electrodes, achieved 100% removal with a stirring time of 10 min, a stirring speed of 200 rpm, and a current density of 2 mA/cm² (Akarsu, et al., 2021). Although these results are superior, the operational conditions differ, including a higher agitation speed and current density, which may not be directly comparable to the present study.

Effects of the factors

As shown in Figure 2a and Figure 2b, the main effects analysis and Pareto plot for microplastic removal, generated using

Table 3. Comparison of different microplastics treated by electrocoagulation

Types of microspheres	Anode	Cathode	Efficiency	Stirring time	Stirring speed	Feed	Reference
PE microbeads	Aluminum	Aluminum	99%	1 hour	60 rpm	15 mA/cm ²	(Perren, et al., 2018)
PE microplastics	Aluminum	Aluminum	98.6 %	1.5 hours	60 rpm	8.07 mA/cm ²	(Elkhatib, et al., 2021)
PE microplastics	Aluminum	Copper	98.7 %	6 hours	150 rpm	10 V	(Shen, et al., 2022)
Microplastic PMMA	Aluminum	Copper	99.1 %	6 hours	150 rpm	10 V	(Shen, et al., 2022)
CA Microplastics	Aluminum	Copper	99.9 %	6 hours	150 rpm	10 V	(Shen, et al., 2022)
PP Microplastic	Aluminum	Copper	99.9 %	6 hours	150 rpm	10 V	(Shen, et al., 2022)
PE microplastics	Fe	Copper	84.6 %	6 hours	150 rpm	10 V	(Shen, et al., 2022)
PMMA microplastic	Fe	Copper	69.5 %	6 hours	150 rpm	10 V	(Shen, et al., 2022)
CA Microplastic	Fe	Copper	96.8 %	6 horas	150 rpm	10 V	(Shen, et al., 2022)
PP Microplastic	Fe	Copper	93.8 %	6 hours	150 rpm	10 V	(Shen, et al., 2022)
Spherical microspheres	Aluminum	Aluminum	92.8%	30 min	70 rpm	10 V	(Kim and Park, 2021)
PE microplastic	Fe	Aluminum	100%	10 min	200 rpm	2 mA/cm ²	(Akarsu, et al., 2021)
PVC microplastic	Fe	Aluminum	100%	10 min	200 rpm	2 mA /cm ²	(Akarsu, et al., 2021)
PA microplastic	Aluminum	Aluminum	83.74 %	2 hours	200 rpm	10 V	(Hu, et al., 2023)
PA microplastic	Aluminum	Fe	86.94 %	2 hours	200 rpm	10 V	(Hu, et al., 2023)
PA microplastic	Fe	Aluminum	90.92 %	2 hours	200 rpm	10 V	(Hu, et al., 2023)
PA microplastic	Fe	Fe	88.38 %	2 hours	200 rpm	10 V	(Hu, et al., 2023)
PE microplastic	Aluminum	Aluminum	97.5 %	30 min	-	12 mA / cm ²	(Xu, et al., 2022)
PE microplastic	Aluminum	Aluminum	98.04%	15 min	70 rpm	2 mA / cm ²	Este estudio

Note: PE: Polyethylene, PMMA: Polymethylmethacrylate, CA: Cellulose acetate, PP: Polypropylene, PVC: Polyvinyl chloride, PA: Polyamide.

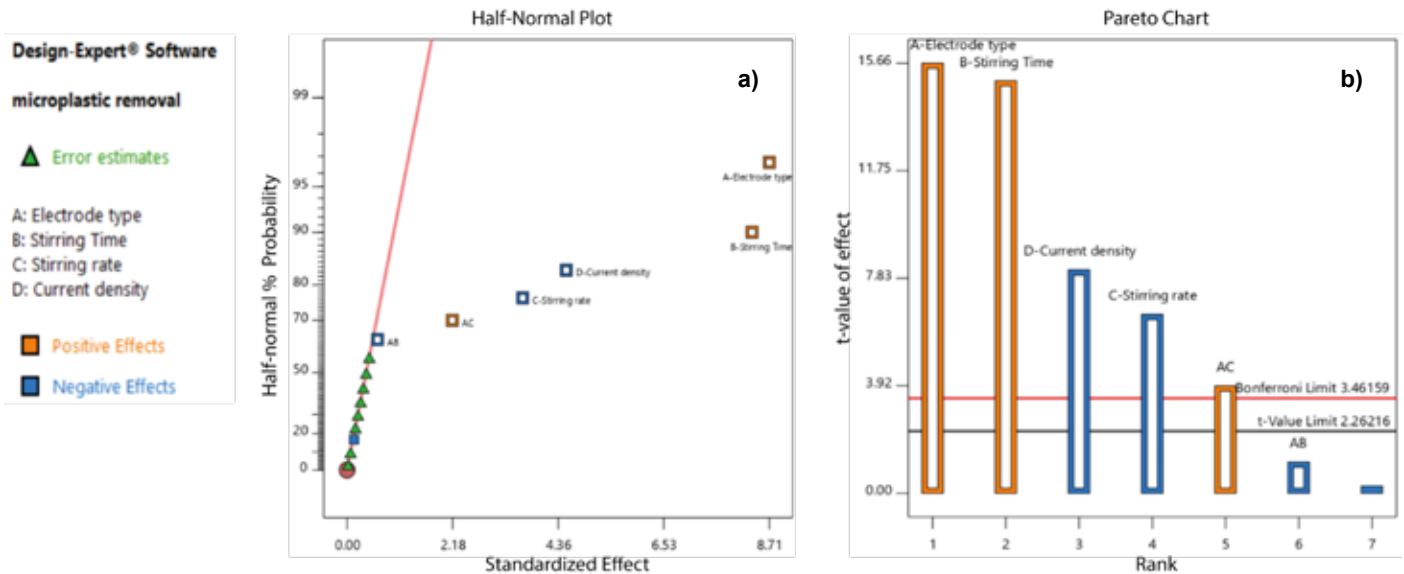

Design-Expert® software, indicate that electrode type (A) and stirring time (B) are the most significant factors. Both, exhibit pronounced positive effects on removal efficiency, exceeding the Bonferroni significance limits. Current density (D) and agitation speed (C) also show significant, though less pronounced, effects, with both positive and negative impacts.

Among the factor interactions, the AC interaction (electrode type and stirring speed) is significant but has a negative effect, unlike AB (electrode type and stirring time), which lacks the desired significant impact. These findings indicate that optimizing electrode type and stirring time is crucial to improve the removal efficiency of microplastics via electrocoagulation.

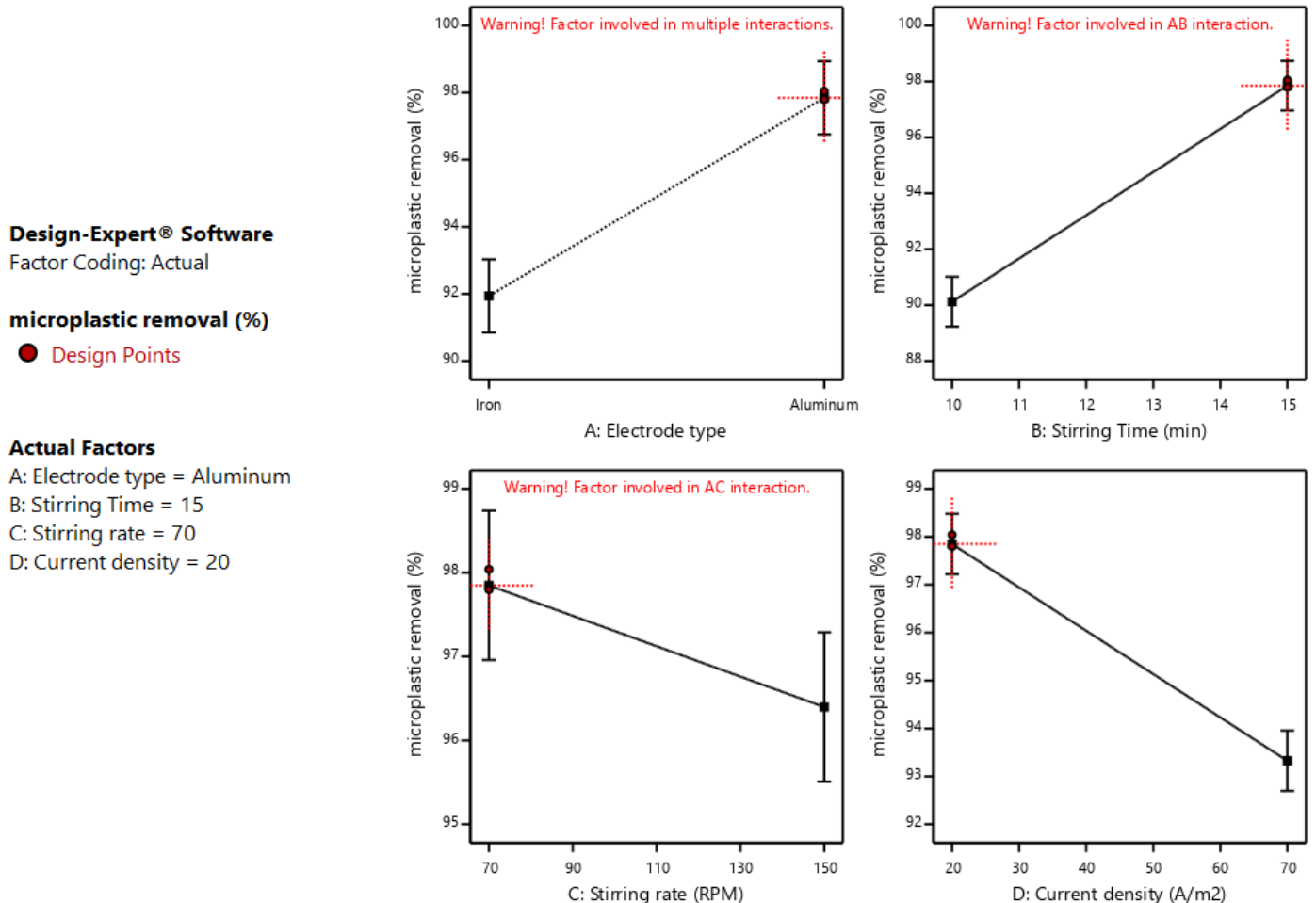

Figure 3. Effects of the parameters in configuration of the highest microplastics removal

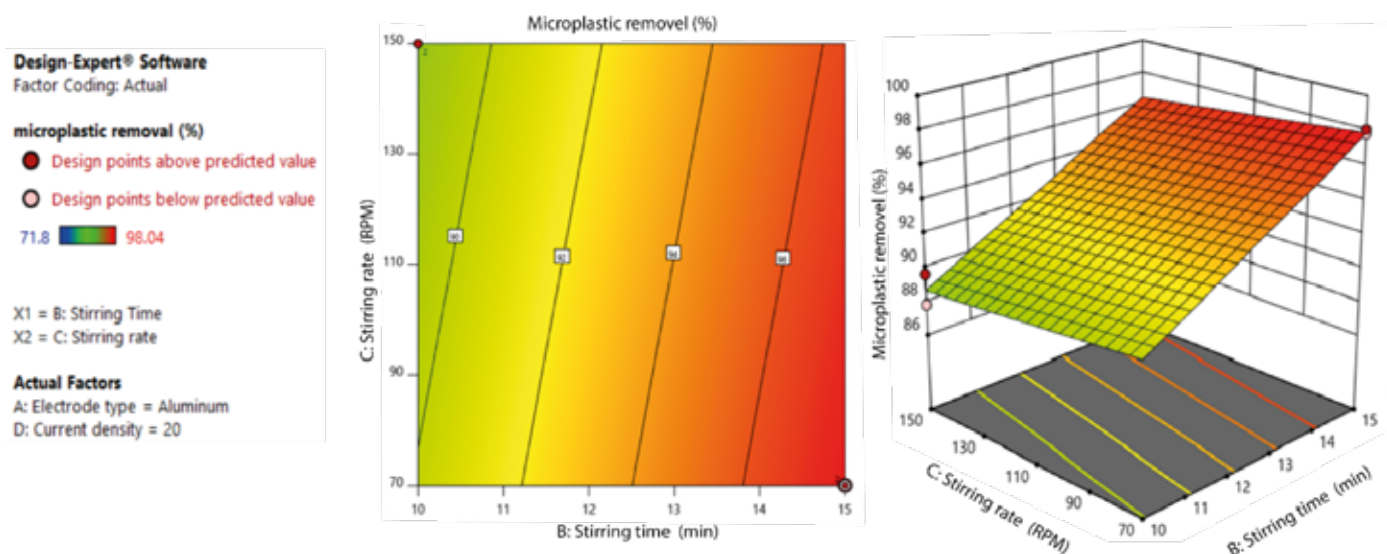

Figure 4. 2D contour plot and 3D surface plot of microplastic removal (%) as a function of study factors

While current density and stirring speed also play a role, their impact is less consistent.

Figure 3 shows the main effects of the four study factors - electrode type, stirring time, stirring speed and current density - on microplastic removal efficiency. The analysis confirms that electrode type (A) and stirring time (B) are the most influential factors, with aluminum electrodes and a stirring time of 15 min resulting in the highest efficiency, exceeding 98%. In contrast, stirring speed (C) and current density (D) have mixed effects. An increase in stirring speed from 70 to 150 rpm and a higher current density from 20 to 70 A/m² reduce microplastic removal efficiency. Interactions between factors, particularly between electrode type and stirring speed (AC), are significant and affect the CE process. Therefore, to optimize microplastic removal using electrocoagulation, it is crucial to properly select the electrode type and stirring time. Additionally, careful adjustment of stirring speed and current density is necessary to mitigate their significant effects on the process.

Figure 4 illustrates the response surface showing the interaction between stirring time (B) and stirring speed (C) on microplastic removal, with the electrode type fixed as aluminum and the current density set at 20 A/m². The two-dimensional contour plot and three-dimensional plot indicate that higher microplastic removal efficiencies, reaching up to 98%, are achieved with longer stirring times and moderate stirring speeds. Specifically, removal increases significantly as the agitation time extends from 10 to 15 minutes, with the optimal agitation speed being around 70 rpm. These figures underscore the importance of optimizing both agitation time and agitation speed to maximize microplastic removal in electrocoagulation processes, emphasizing that a proper combination of these factors is essential for achieving optimal results.

Fitting of the mathematical models

By applying the experimental design in the software, it was shown that the removal of microplastics using the

Table 4. ANOVA results for experimental model df. degrees of freedom

Source	Sum of Squares	df	Mean Square	F-value	p-value
Model	737.8	6	122.97	99.35	< 0.0001
A-Electrode type	303.63	1	303.63	245.31	< 0.0001
B-Stirring Time	279.39	1	279.39	225.73	< 0.0001
C-Stirring rate	52.49	1	52.49	42.41	0.0001
D-Current density	81.81	1	81.81	66.1	< 0.0001
AB	1.6	1	1.6	1.29	0.2849
AC	18.88	1	18.88	15.25	0.0036
Residual	11.14	9	1.24		
Lack of Fit	0.0812	1	0.0812	0.0588	0.8146
Pure Error	11.06	8	1.38		
Cor Total	748.94	15			

df. degrees of freedom

electrocoagulation method depends on the following factors: A) electrode type, B) stirring time, C) stirring speed, and D) current density, as shown in Equation 4. The experimental design tested linear models and two-factor interactions based on the *p*-value, with a confidence level of 95 %.

(4)

$$\% \text{ Microplastics Removal} = 86.6438 + 4.35625 A + 4.17875 B + -1.81125 C - 2.26125 D - 0.31625 AB + 1.08625 AC$$

In the study, the F-value test and *p*-values were used to evaluate the significance of each parameter of Model 4 for microplastic removal, including linear interactions. Table 4 shows that the ANOVA analysis confirms that the overall model is highly significant (F-value = 99.35, *p* < 0.0001), indicating that the factors considered have a significant effect on microplastic removal. The individual factors - electrode type (A), stirring time (B), stirring speed (C), and current density (D) - all show significant influence, with *p*-values < 0.0001. Among these, electrode type (A) and stirring time (B) are the most influential factors, with sums of squares of 303.63 and 279.39, respectively, and high F-values (245.31 and 225.73). Interactions between factors reveal varying levels of significance. The AC interaction is significant (*p* = 0.0036), while the AB interaction is not (*p* = 0.2849). Additionally, the lack of fit is not significant (*p* = 0.8146), indicating that the model aligns well with the experimental data. Therefore, electrode type and stirring time are identified as the critical factors for optimizing microplastic removal.

According to Table 5, the regression model indicators for microplastic removal show an excellent fit. The coefficient of determination (*R*²) is 0.99, indicating that 99% of the variability in microplastic removal is explained by the model (Fu, et al., 2007). The adjusted *R*² of 0.98 confirms the model's robustness, even after accounting for the number of predictors. The predicted *R*² of 0.95 suggests strong predictive capability for new data. An adequate accuracy of 34.27 reflects a high signal-to-noise ratio, further validating the model's reliability. The standard deviation of 1.11 and the coefficient of variation (C.V.%) of 1.28% shows low relative variability, confirming the high reproducibility of the model. With a mean value of 86.64, the results underscore the effectiveness of the proposed method for microplastic removal. In summary, these indicators collectively confirm that the regression model is both reliable and effective in predicting and optimizing microplastic removal using electrocoagulation.

Table 5. Linear model fits in the removal of microplastics in the electrocoagulation treatment system

Descriptive	Model Indicators
<i>R</i> ²	0.99
Adjusted <i>R</i> ²	0.98
Predicted <i>R</i> ²	0.95
Adeq Precision	34.27
Std. Dev.	1.11
Mean	86.64
C.V. %	1.28

Conclusion

In conclusion, this study demonstrated that the electrocoagulation configuration using aluminum electrodes, a 15-minute agitation time, an agitation speed of 70 rpm, and a current density of 20 A/m² achieved a microplastic removal efficiency of 98.04%, which is highly effective and competitive compared to previous studies. ANOVA results indicate that electrode type and agitation time are the most influential factors, while agitation speed and current density also play significant roles in improving process efficiency. When compared with previous studies, the methodology employed in this work not only significantly reduces the required agitation time but also maintains or even improves microplastic removal efficiency, compared to longer operational configurations and varying current densities. In addition, the response surface plots emphasize the critical role of optimizing both agitation time and speed to maximize microplastic removal. These findings highlight the potential of the proposed electrocoagulation method for practical applications, offering a fast and efficient solution for microplastic removal under various operational conditions. Furthermore, the study lays a solid foundation for future research and optimization in the treatment of microplastic-contaminated waters.

References

- Akarsu, C., Kumbur, H. & Kideys, A.E. (2021). Removal of microplastics from wastewater through electrocoagulation-electroflotation and membrane filtration processes. *Water Science & Technology*, 84, 7, pp. 1648–1662. DOI:10.2166/wst.2021.356
- Andrady, A. L. (2011). Microplastics in the marine environment. *Marine Pollution Bulletin*, 62, 8, pp. 1596–1605. DOI:10.1016/j.marpolbul.2011.05.030
- Antunes, J.C., Frias, J.G.L., Micaelo, A.C. Sobral, P. (2013). Resin pellets from beaches of the Portuguese coast and adsorbed persistent organic pollutants. *Estuarine, Coastal and Shelf Science*, 130, pp. 62–69. DOI:10.1016/j.ecss.2013.06.016
- Bannick, C.G., Szweczyk, R., Ricking, M., Schniegler, S., Obermaier, N., Barthel, A.K., Altmann, K., Eisentraut, P. & Braun, U. (2019). Development and testing of a fractionated filtration for sampling of microplastics in water. *Water Research*, 149, pp. 650–658. DOI:10.1016/j.watres.2018.10.045
- Barnes, K.A., Galgani, F., Thompson, R.C. & Barlaz, M. (2009). Accumulation and fragmentation of plastic debris in global environments. *Philos. Trans. R. Soc. B Biol. Sci.*, 364, 1526, pp. 1985–1998. <https://doi.org/10.1098/rstb.2008.0205>
- Bhatt, P., Pathak, V.M., Bagheri, A.R. & Bilal, M. (2021). Microplastic contaminants in the aqueous environment, fate, toxicity consequences, and remediation strategies. *Environmental Research*, 200, 111762. <https://doi.org/10.1016/j.envres.2021.111762>
- Cózar, A., Echevarría, F., González-Gordillo, J.I. & Duarte, C.M. (2014). Plastic debris in the open ocean. *Proc. Natl. Acad. Sci.*, 111, 28, pp. 10239–10244. <https://doi.org/10.1073/pnas.1314705111>
- Dong, C-D., Chen, C-W., Chen, Y.C., Chen, H-H., Lee, J-S. & Lin, C-H. (2020). Polystyrene microplastic particles: In vitro pulmonary toxicity assessment. *Journal of Hazardous Materials*, 385, pp. 121575. <https://doi.org/10.1016/j.jhazmat.2019.121575>

- Ebrahimbabaie, P., Yousefi, K. & Pichtel, J. (2022). Photocatalytic and biological technologies for elimination of microplastics in water: Current status. *Science of The Total Environment*, 806, pp. 150603. <https://doi.org/10.1016/j.scitotenv.2021.150603>
- Elkhatib, D., Oyanedel-Craver, V. & Carissimi, E. (2021). Electrocoagulation applied for the removal of microplastics from wastewater treatment facilities. *Separation and Purification Technology*, 276, 118877. <https://doi.org/10.1016/j.seppur.2021.118877>
- Fu, J., Zhao, Y. & Qiuli Wu, Q. (2007). Optimising photoelectrocatalytic oxidation of fulvic acid using response surface methodology. *Journal of Hazardous Materials*, 144, 1–2, pp. 499–505. <https://doi.org/10.1016/j.jhazmat.2006.10.071>
- Grbic, J., Nguyen, B., Guo, E., You, J.B., Sinton, D. & Rochman, C.M. (2019). Magnetic Extraction of Microplastics from Environmental Samples. *Environmental Science & Technology Letters*, 6, 2, pp. 68–72. <https://doi.org/10.1021/acs.estlett.8b00671>
- Gutiérrez, H. & Salazar, V., (2012). *Análisis y diseño de experimentos*, McGraw Hill, México 2012
- Holt, P.K., Barton, G.W. & Mitchell, C.A. (2005). The future for electrocoagulation as a localised water treatment technology. *Chemosphere*, 59, 3, pp. 355–367. <https://doi.org/10.1016/j.chemosphere.2004.10.023>
- Hu, Y., Zhou, L., Zhu, J. & Gao, J. (2023). Efficient removal of polyamide particles from wastewater by electrocoagulation. *Journal of Water Process Engineering*, 51, pp. 103417. <https://doi.org/10.1016/j.jwpe.2022.103417>
- Huang, H., Sun, Z., Liu, S., Di, Y., Xu, J., Liu, C., Xu, R., Song, H., Zhan, S. & Wu, J. (2021). Underwater hyperspectral imaging for in situ underwater microplastic detection. *Science of The Total Environment*, 776, 145960. <https://doi.org/10.1016/j.scitotenv.2021.145960>
- Khandegar, V. & Saroha, A. K. (2013). Electrocoagulation for the treatment of textile industry effluent – A review. *Journal of Environmental Management*, 128, pp. 949–963. <https://doi.org/10.1016/j.jenvman.2013.06.043>
- Kim, K. T. & Park, S. (2021). Enhancing Microplastics Removal from Wastewater Using Electro-Coagulation and Granule-Activated Carbon with Thermal Regeneration. *Processes*, 9, 4, pp. 2 – 15. <https://doi.org/10.3390/pr9040617>
- Lambert, S. & Wagner M. (2016). Characterisation of nanoplastics during the degradation of polystyrene. *Chemosphere*, 145, pp. 265–268. DOI:10.1016/j.chemosphere.2015.11.078
- Leslie, H.A., van Velzen, M.J.M., Brandsma, S.H., Vethaak, A.D., Vallejo, J.J.G. & Lamoree, M.H. (2022). Discovery and quantification of plastic particle pollution in human blood. *Environment International*, 163, pp. 107199. <https://doi.org/10.1016/j.envint.2022.107199>
- Liu, X., Yuan, W., Di, M., Li, Z. & Wang, J. (2019). Transfer and fate of microplastics during the conventional activated sludge process in one wastewater treatment plant of China. *Chemical Engineering Journal*, 362, pp. 176–182. DOI:10.1016/j.ccej.2019.01.033
- Ma, B., Xue, W., Hu, C., Liu, H., Qu, J. & Li, L. (2019). Characteristics of microplastic removal via coagulation and ultrafiltration during drinking water treatment. *Chemical Engineering Journal*, 359, pp. 159–167. DOI:10.1016/j.ccej.2018.11.155
- Malankowska, M., Echaide-Gorriazab, C. & Coronas, J. (2021). Microplastics in marine environment: a review on sources, classification, and potential remediation by membrane technology. *Environmental Science: Water Research & Technology*, 7, 2, pp. 243–258. DOI:10.1039/D0EW00802H
- Perren, W., Wojtasik, D. & Cai, Q. (2018). Removal of Microbeads from Wastewater Using Electrocoagulation. *ACS Omega*, 3, 3, pp. 3357–3364. DOI:10.1021/acsomega.7b02037
- Shen, M., Zhang, Y., Almatrafi, E., Hu, T., Zhou, C., Song, B., Zeng, Z. & Zeng, G. (2022). Efficient removal of microplastics from wastewater by an electrocoagulation process. *Chemical Engineering Journal*, 428, pp. 131161, DOI:10.1016/j.ccej.2021.131161
- Slootmaekers, B., Carteny, C.C., Belpaire, C., Saverwyns, S., Fremout, W., Blust, R. & Bervoets, L. (2019). Microplastic contamination in gudgeons (*Gobio gobio*) from Flemish rivers (Belgium). *Environmental Pollution*, 244, pp. 675–684. DOI:10.1016/j.envpol.2018.09.136
- Xu, R., Yang, Z., Niu, Y., Xu, D., Wang, J., Han, J. & Wang, H. (2022). Removal of microplastics and attached heavy metals from secondary effluent of wastewater treatment plant using interpenetrating bipolar plate electrocoagulation. *Separation and Purification Technology*, 290, pp. 120905. DOI:10.1016/j.seppur.2022.120905
- Zailani, L. W. M. & Zin, N. S. M., (2018). Application of Electrocoagulation In Various Wastewater And Leachate Treatment-A Review. *IOP Conference Series: Earth and Environmental Science*, 140, 012052. <https://iopscience.iop.org/article/10.1088/1755-1315/140/1/012052/meta>