

AN INVESTIGATION INTO THE IMPACT OF ELECTRICAL PULSE CHARACTER ON SURFACE TEXTURE IN THE EDM AND WEDM PROCESS

Dorota Oniszcuk, Rafał Świercz

Summary

The article discusses the results of experimental studies on the influence of the character of the pulse current and voltage on surface texture after the Wire Electrical Discharge Machining (WEDM) and the Electrical Discharge Machining (EDM). The measurement circuit has been developed to determine the real current-voltage characteristics. Based on the survey developed mathematical models describing the effects of selected parameters of pulse electrical the on the surface texture.

Keywords: wire electrical discharge machining, WEDM, electrical discharge machining, EDM, current and voltage waveforms, surface structure

Ocena wpływu charakteru impulsów elektrycznych w procesie EDM i WEDM na stan struktury geometrycznej powierzchni

Streszczenie

W artykule przedstawiono analizę wyników badań doświadczalnych wpływu charakteru impulsów natężenia i napięcia prądu elektrycznego na strukturę geometryczną powierzchni (SGP) po obróbce wycinaniem (WEDM) i drążeniem elektroerozyjnym (EDM). Opracowano i zbudowano stanowiska pomiarowe do wyznaczenia rzeczywistych charakterystyk natężenia i napięcia prądu. Na podstawie wyników przeprowadzonych badań opracowano modele matematyczne opisujące wpływ wybranych parametrów impulsów elektrycznych na strukturę geometryczną powierzchni.

Słowa kluczowe: wycinanie elektroerozyjne, WEDM, drążenie elektroerozyjne, EDM, charakterystyki napięcia i natężenia prądu, struktura powierzchni

1. Introduction

Electrical discharge machining is considered to be accurate method for forming objects with hard to machine and complex geometry. Research conducted by many scientists prove that a fundamental feature influencing the properties of the parts after manufacturing is the state of the surface layer. In the

Address: Dorota ONISZCZUK, M.Sc. Eng., Rafał ŚWIERCZ, M.Sc. Eng., Institute of Manufacturing Technology, Warsaw University of Technology, 00-663 Warsaw, Al. Niepodległości 222, e-mail: rsw@meil.pw.edu.pl,

process of EDM and WEDM, this layer is formed by the overlapping of a single traces of electrical discharges and has a point isotropic nature.

EDM and WEDM have a complex character, they take place in four-phase system (liquid phase – dielectric, constant – products processing, gas – gases and vapors, and the plasma phase – ions and electrons). Condition of the surface layer after the manufacturing is mainly results of thermal processes (melting and evaporation), and phase transitions. The top layer of the workpiece has a redesignation for core material metallographic structure [1-5].

Experimentally concluded that parameters of the surface texture have considerable the influence of:

- friction and wear processes associated components,
- deformation and strength of materials,
- resistance to corrosion,
- vibration activity,
- the quality of coatings layers,
- properties of aero-and hydro-mechanical [6].

The primary factor in determining treatment and condition of the surface layer after EDM and WEDM is the character of current and voltage waveform.

2. Analysis of the voltage-current waveforms

Measurement stations have been developed to determine the current-voltage characteristics of generators machines Charmilles: WEDM Robofil 190 (Fig. 1a) and EDM Form 2LC ZNC (Fig. 1b). Machines were equipped with transistor generators. Pearson's sensor (Hall sensor) was used to current measurement for WEDM, and a special shunt current was used for EDM. To measure the voltage used special voltage probe. Different method of measuring current is results of much longer time of current pulses in EDM (Pearson sensor is saturating for the pulse time over a few microseconds).

Waveforms of electric current and voltage were recorded in the memory of the oscilloscope made by the National Instruments (NI) 5133. Application developed in LabView environment was responsible for control of oscilloscope and transferring recorded data to the computer's hard disk, in a continuous process of EDM and WEDM.

The data acquisition proceeded with the following parameters:

- dual-channel data recording,
- sampling frequency: 100 MHz,
- data record length: 5 000 000,
- amplitude measurement range:

- 25 V voltage discharges by the probe 10 x decreasing,
- from 0 to 3 V voltage drop across the shunt for a settable current,
- sensitivity Pearson sensor 0.1 V/A.

a)

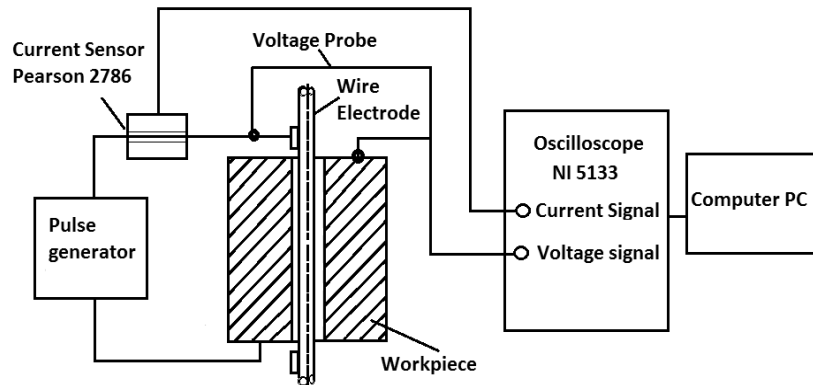

b)

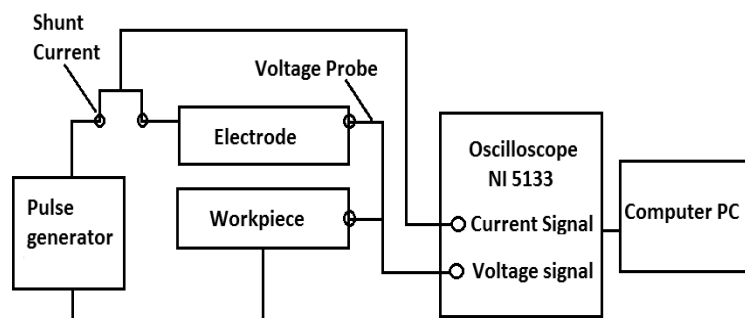

Fig. 1. Measuring circuit: a) WEDM, b) EDM

An important element of EDM and WEDM monitoring is fast data acquisition, which is allowing for control and optimization of parameters. Strong influence of the material removal is the voltage and current along the slot. High frequency pulses in EDM and WEDM requires the rapid acquisition of data for registration and classification of electrical discharge.

The processing and statistical analysis of received data: current-voltage waveforms, was done in DIAdem from National Instrument. The results of measurements allowed the determination of reliable studied waveform chart value. Examples of waveforms $U(t)$, $I(t)$, are shown in Fig. 3 and Fig. 4.

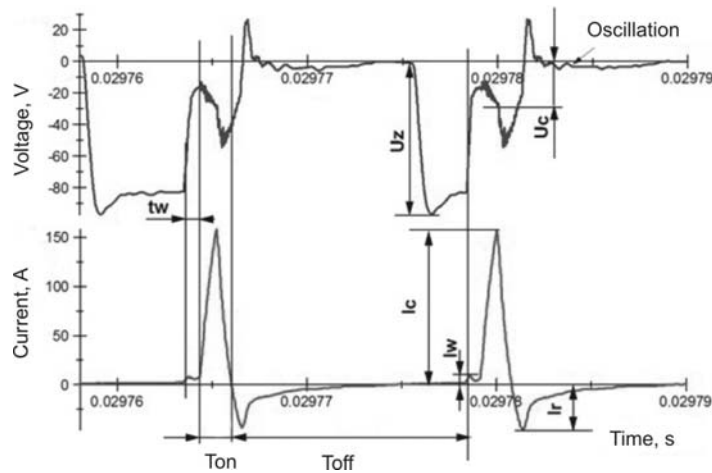

Fig. 2. Current and voltage waveforms in WEDM for the following parameters: discharge voltage $U_c - 25$ V, supply voltage $U_z - (-85)$ V, current $I_c - 150$ A, initial current $I_w - 6$ A, pulse time $t_{on} - 2 \mu s$, time interval $t_{off} - 14 \mu s$

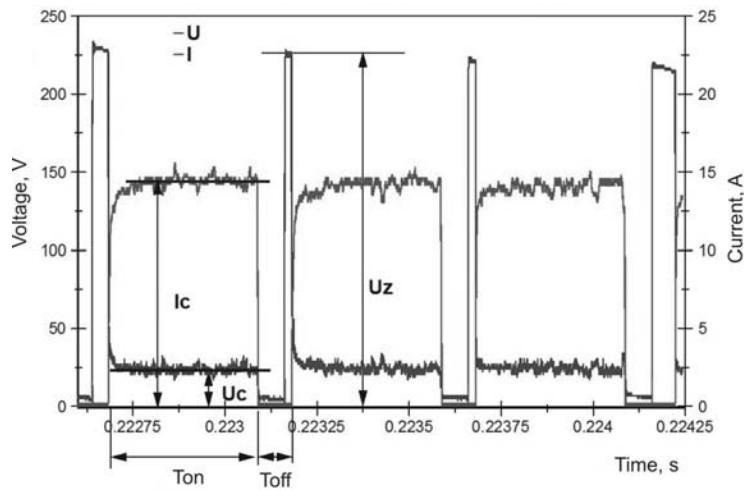

Fig. 3. Current and voltage waveforms in EDM for the following parameters: voltage $U_c - 25$ V, supply voltage $U_z - 225$ V, current $I - 14,3$ A, pulse time $t_{on} - 80 \mu s$, time break $t_{off} - 18 \mu s$

Voltage-current waveforms (Fig. 2) can be characterized by the following parameters:

- I_c – height of the peak current during discharging,
- I_r – height of the peak reverse current, occurs due to the current capacitance of the system [7-9],

- I_w – initial current,
- U_z – open circuit voltage, this is the system voltage when the EDM circuit is in the open state and the energy has been built up for discharging,
- U_c – discharge voltage,
- t_{on} – pulse duration time, the time required for the current to rise and fall during discharging,
- t_{off} – time break, this is the time from the end of one pulse to the beginning of the next pulse with current,
- t_w – initial pulse time.

In the case of WEDM at the end of discharge by inductance and capacitance voltage slowly decreases to a value in the steady state is called an echo effect [8], (voltage varies over a long period after discharge and then decreases). Another phenomenon which occur in WEDM is a reverse current appearing at the end of the current pulse. Negatively charged dirt particles are accelerated in an electric field towards the positively charged electrode collide with it and provide a negative charge.

Investigated machines generators have different capabilities of settable processing parameters, as well as the character of the voltage-current waveforms. In EDM was observed rectangular character of pulses. Adjustable parameters are: pulse time t_{on} , the time interval t_{off} and the intensity discharge I_c . Instead that in the process of WEDM, is characterized by triangular current waveforms (resulting from the short times of the order of a microsecond pulse for roughing), possible to set parameters are: pulse time t_{on} – it depends on it the peak discharge value I_c , the time interval t_{off} , discharge voltage U_c , initial current I_w .

3. Methodology of research

This article present an experimental study of influence of selected parameters of electrical impulses in the surface texture after the EDM and WEDM (Table 1 and 2). In the case of EDM, a study was executed according to the design planned three-level Box Behnken. The machined samples with dimensions of 12 x 12 x 3 mm, hardened up to 52 HRC steel WNL (1.2713), electrode was made of copper (M1E) and kerosene was used as the dielectric. Stable values of input parameters was set on the basis of the characteristics of the generator machine. An experiment was aimed at investigating the effect of the input factors at three equidistant levels of variability allowed the determination of regression equations with high correlation level and low scatter of values. Determined ranges of variation correspond to the processes used in production.

Using wire electrical discharge machining cut rectangular cubes made of high alloyed tool steel NC10 with a hardness of 62 HRC. Samples was

manufacturing in one clamping block of material (eliminate errors resulting from the fixing object). 12 profiles were cut with dimensions of 10 x 10 x 100 mm. The electrode was a brass wire with a diameter of 0.25 mm (AC Brass 400 – 450 N/mm² and an elongation of 25%). Dielectric (demineralized and deionized water) was given into the gap of the top and bottom nozzle. The study was based on a modified Hartley design experiment. This experiment is characterized by the assumption of a constant accuracy of the model defined by the variance along the distance from the center point of the plan. The choice of such an experiment made it possible to investigate the utility of variation (with five levels of value) the influence of individual input parameters on the effects of treatment [10].

Table 1. The selected process parameters in the EDM experiment

The input parameters	
Current amplitude I_c in one pulse in the range:	3 – 14,3 A
Pulse time t_{on} in the range:	13 – 400 μ s
Time break between the pulses t_{off} in the range:	9 – 150 μ s
The output parameters fixed	
Discharge voltage U_c	$U_c = 25$ V
The output parameters	
Parameters of the surface texture: S_a, R_{sm}, S_{ds}	

Table 2. The selected process parameters in the WEDM experiment

The input parameters	
Initial current amplitude I_w in the range:	4 – 12 A
Pulse time t_{on} in the range:	0,6 – 1 μ s
The output parameters fixed	
Discharge voltage U_c	–30 V
Scrolling speed wire V_d	10 m/min
Pressure of the dielectric p	0,9 MPa
Wire tension F_n	1,4 daN
The output parameters	
Parameter of the surface texture: R_a	
Dimensional accuracy	

The ranges of parameter values in the design experiment, were chosen based on analyzing the technological tables for the type of material steel for roughing and single pass cutting. In accordance with the requirements of the experiment, each points of the plan assigned to specific sets of the levels of input parameter values that were fixed for cutting each profile. Selection of

parameters was made in reconnaissance research which takes into account the processing stability without the wire rupture.

The study of surface texture included measurements of characteristics associated the height of the roughness, characteristics of the horizontal profile, the shape of the disparities and the complexity of construction of geometric inequalities. For each surface was measured 3D areal and profile along with their parameters. The measurements were executed on machine FORMTALYSURF Series 2. Figure 4 a, b and 5 shows the images from the measured 3D surface after EDM and WEDM and corresponding processing parameters (voltage and current waveforms, during the manufacturing). In addition to samples after WEDM were made measurements of surface flatness in the coordinate measuring machine from Carl Zeiss Vista.

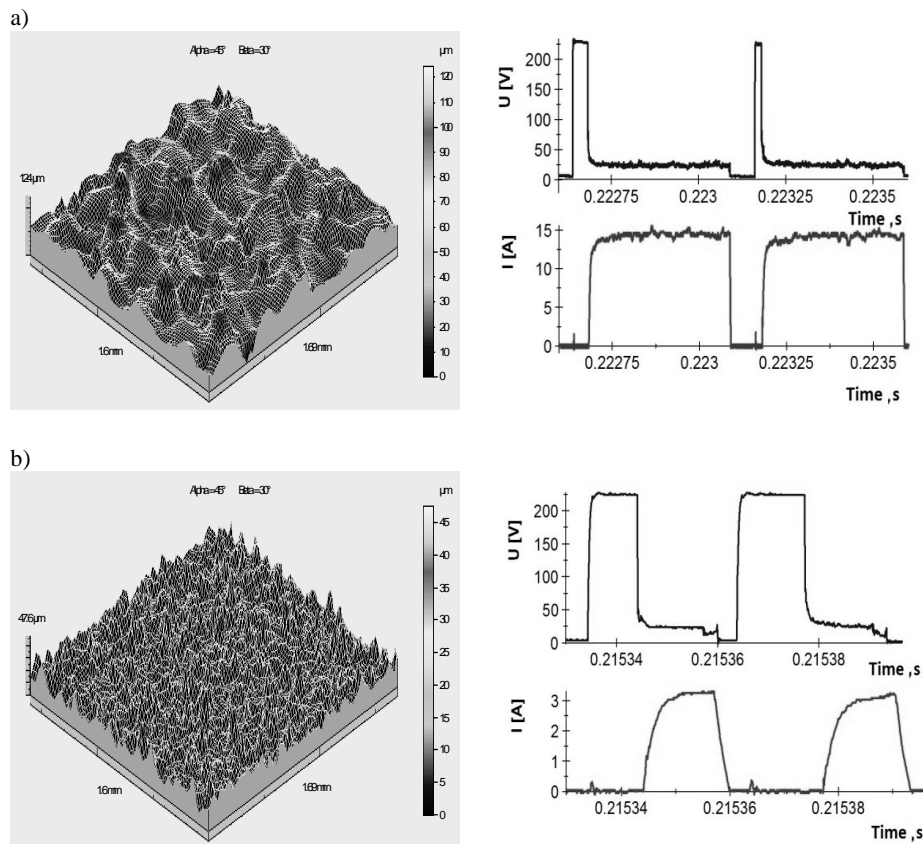

Fig. 4. Stereometric image of the surface with recorded wave forms current voltage characteristics after EDM: a) $U_c = 25 \text{ V}$, $I_c = 14,3 \text{ A}$, $t_{\text{on}} = 80 \text{ } \mu\text{s}$, $t_{\text{off}} = 18 \text{ } \mu\text{s}$, b) $U_c = 25 \text{ V}$, $I_c = 3,2 \text{ A}$, $t_{\text{on}} = 11 \text{ } \mu\text{s}$, $t_{\text{off}} = 150 \text{ } \mu\text{s}$

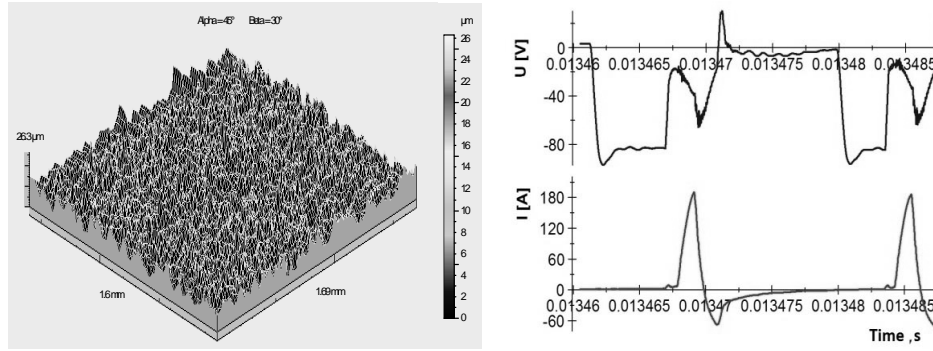

Fig. 5. Stereometric image of the surface with recorded waveforms current voltage characteristics after WEDM: $U_c = 25$ V, $I_c = 185$ A, $I_w = 6$ A, $t_{on} = 1$ µs, $t_{off} = 12$ µs

4. Analysis of the results

Mathematical models describing the effects of selected processing parameters on the surface texture was based on the conducted research developed. They were expressed by regression equation of the second degree polynomial function (Table 3) in STATISTICA. For each equation determinate the coefficient of correlation R. Closer the R value to unity, is the better representation of variability of the study characteristic. The important of the resulting correlation coefficient (the adequacy of the level $\alpha = 0.05$) examined by the test of Fisher-Snedecor (for $F/F_{kr} > 1$ factor R is important). Verification of the regression equation coefficients was doing using test t-student ($t_1, t_n, t_{n+1} > t_{kr}$) [10]. Selected dependence regression analysis presented in Table 3.

Table 3. Regression equations describing the influence of the parameters on surface texture

Parameters of the surface texture after EDM	R	F/F _{kr}
$Sa = 3,13 - 0,37 I + 0,09 t_{on} + 0,037 I^2 - 0,00005 t_{on}^2 - 0,002 I t_{on} + 0,00005 t_{on} t_{off}$	0,924	37,74
$Rsm = -0,129 + 0,022 I + 0,0006 t_{on} - 0,0009 I^2 - 0,000001 t_{on}^2$	0,83	12,14
$Sds = 2047 - 80 I + 0,00578 t_{on}^2 - 0,16 I t_{on} - 0,008 t_{off} t_{on}$	0,85	13,65
Parameters of the surface texture after WEDM		
$Ra = 1,64 + 1,17 t_{on} - 0,04 I_w t_{on}$	0,75	3,87
$Pl = 0,025 - 0,005 I_w + 0,07 I_w t_{on}$	0,96	36,53

Equations are characterized by a high degree of correlation R and relation F/F_{kr} is much larger than unity. Graphical presentation of the results is shown in Fig. 6, 7.

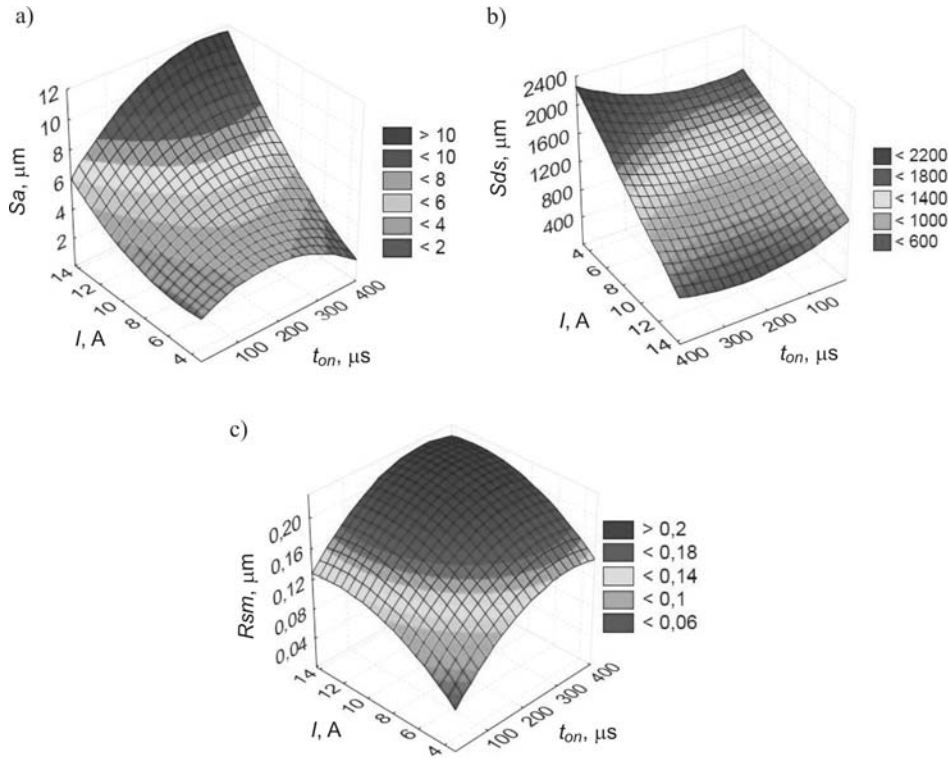
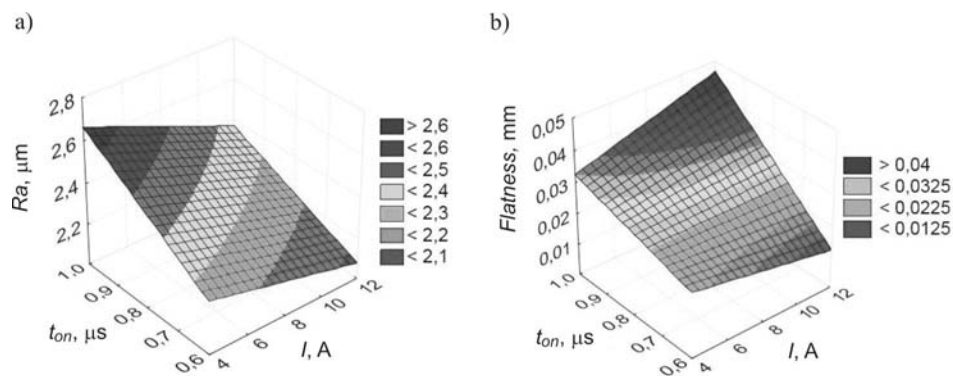

Fig. 6. The dependence of surface texture parameters after EDM from pulse time t_{on} and the current I_c at constant time break $t_{off} = 80\mu s$

Parameters of the roughness height (for example Sa – arithmetic mean of the deviation from the average – Fig. 4a) mainly depend on the discharge energy. They are not directly proportional dependence. At small amperage values (of about 3 A), increasing the discharge time (and thus energy) does not cause a significant increase in the parameter Sa . It might be related to the amount of energy produced and delivered to the workpiece in the process of discharge, which depend on the amperage.

Density of tops Sds is inversely proportional to the size of pulse energy, increasing energy decreases Sds density (Fig. 6b).

Mean spacing Rsm (Fig. 6c) and vertical parameters of roughness increase with increasing discharge energy.



Rys. 7. The dependence of surface texture parameters after WEDM from pulse time t_{on} and the current I_w

Surface roughness after WEDM (Fig.7a) was obtained about value $Ra = 2$ microns. The main parameter which has a influence of the value of Ra is the pulse time t_{on} . Surface roughness increases with the increasing pulse time. A similar relationship was observed for the surface flatness (Fig.7b). Parameter which influences of the flatness deviation is the pulse time, along with the increase value of it the deviation increases. The major problem is the flatness in the central part of the sample. It is a place of highest concentration of residual processing products (resulting from a zero velocity dielectric – the clash of two liquid jets), which help electrical discharge – ionization of the dielectric. The intensity of the initial pulse does not affect both the value of surface roughness and flatness.

Conclusions

The developed measurement circuit made it possible to determine the characteristics of machines generators, which is necessary for the proper selection of parameters implemented in the design experiments (stable in the whole area of variation). Designated regression parameters depend on the actual treatment (measured) are characterized by a high degree of correlation. They show that the main factors affecting the surface texture after EDM and WEDM is the current intensity and pulse duration (at fixed other parameters of treatment). Developed regression equations can be used in the design process in EDM and WEDM manufacturing technology as guidance WEDM parameter selection, in order to achieve the desired qualities characteristics of surface texture. Other studies will be presented in future articles.

Acknowledgements

This scientific work has been supported from the funds dedicated to scientific purposes for the years 2008 – 2012 as a research project.

References

- [1] A. MIERNIKIEWICZ: Doświadczalno-teoretyczne podstawy obróbki elektroerozyjne (EDM), Kraków 2000.
- [2] A. RUSZAJ, W. GRZEŚ: Manufacturing of sculptured surface using EDM and ECM processes. *Machining of Complex Sculptured Surfaces*, Springer-Verlag, London 2012.
- [3] B. NOWICKI: Zaawansowane metody opisu i pomiarów struktury geometrycznej powierzchni. *Mechanik*, **80**(2007)2.
- [4] J. KOZAK, K. RAJURKAR: Modeling and Simulation of Micro EDM Process. *CIRP Annals – Manufacturing Technology*, (2003).
- [5] J.P. KRUTH, J. VAN HUMBEECK, L. STEVENS: Micro structural investigation and metallographic analysis of the white layer of a surface machined by electrodischarge machining. *Proc. ISEM XI, Losanna 1995*, 849-862.
- [6] K. OCZOŚ, V. LIUBIMOV: Struktura geometryczna powierzchni. Oficyna Wydawnicza Politechniki Rzeszowskiej, Rzeszów 2008.
- [7] R.R. HEBBAR: Micro-hole drilling by electrical discharge machining. PhD dissertation, Purdue University, West Lafayette 1992.
- [8] J.L. KUO: Ringing effect analysis of the digital current pulse generator for the linear rail gun. *IEEE Industry Applications Society Annual Meeting*, **176**(2002)1.
- [9] K. TAKAHATA, Y.B. GIANCHANDANI: Batch mode micro-electro-discharge machining. *Journal of Microelectromechanical Systems*, **102**(2002)11.
- [10] M. KORZYŃSKI: Metodyka eksperymentu, planowanie, realizacja i statystyczne opracowanie wyników eksperymentów technologicznych. Warszawa 2006.

Received April 2012