

MODELLING AND SIMULATION OF MANUFACTURING PROCESSES IN MANAGING AND PLANNING OF MACHINES' SETUP

Milan Gregor, Józef Matuszek, Dariusz Plinta

Summary

In the paper, there is presented the practical application of the modelling and simulation in managing and planning of machines' setup. There are described principles and stages of the production system improvement with the theory of constraints (TOC) and illustrated by the example of analysis of the whole production line, which aim was the bottleneck determining, and the analysis of operations, which are realized in the bottleneck. Main attention in this analyse was focused on the problem of the production setup. Exchange of tools and reconversion of production devices on the production of other product are non value added activities. It means activities, which we should limit. There is presented, that with use of simulation it is possible to check different variants of possible ways of machines' setup and to choose the best process run for realization.

Keywords: manufacturing processes, planning of machines' setup, modelling and simulation

Modelowanie i symulacja procesów wytwarzania w zarządzaniu i planowaniu przebrojeń

Streszczenie

W artykule przedstawiono praktyczne zastosowanie modelowania i symulacji w zarządzaniu i planowaniu przebrojeń maszyn. Opisano zasady oraz etapy doskonalenia systemu produkcyjnego zgodne z teorią ograniczeń. Zilustrowano je praktycznym przykładem analizy linii produkcyjnej, której celem było ustalenie jej wąskiego gardła oraz szczegółowa analiza czynności wykonywanych na zidentyfikowanym ograniczającym stanowisku – wąskim gardle procesu. Główną uwagę zwrócono na problem przebrojeń linii produkcyjnych. Wymiana narzędzi i przestawienie urządzeń na produkcję innego wyrobu jest działaniem niedodającym wartości, a więc takim, które należy ograniczyć. Za pomocą symulacji można sprawdzić różne warianty sposobów przebrojeń i wybrać do realizacji najlepszy.

Słowa kluczowe: procesy wytwarzania, planowanie przebrojeń, modelowanie i symulacja

1. Company's competitiveness on the market

Traditionally, an increase of productivity and competitiveness of companies on the market was usually connected to factors like, among others: improved

Address: Professor Milan GREGOR, Professor Józef MATUSZEK, Dariusz PLINTA, D.Sc.
Eng., Prof. ATH, University of Bielsko-Biała, Department of Industrial Engineering,
43-309 Bielsko-Biała, Willowa 2, Poland, phone: (0-48, 33) 8279253, e-mail:
jmatuzek@ath.bielsko.pl, dplinta@ath.bielsko.pl

technological conditions and management processes, better quality of products and employment, innovativeness, readiness to flexible organizational changes or development of human resources. Formation of these factors has been undertaken and the issue was considered mainly from the point of view of technical preparation of manufacturing in the production systems.

In highly industrialised countries, e.g. in Japanese factories, activities aimed at improving productivity have recently taken into account the social aspect of performed works, and a notion of social work efficiency appeared in the factories. The factors of productivity improvement were expanded, macro-economic conditionings of employment, collective social policy solutions, creating new workplaces, organisation and the level of educational system, recruitment policy, and others. The modern concept of productivity considers humans, not capital, the most important. Two companies may have the same capital, but one of them is competitive on the market and the other is characterized by falling production and lack of development. The situation depends on human resources quality, which, in turn, is related to work and company management [1, 2].

Experience of the production processes realised for the last ten years have shown that a very important factor of enterprise profitability (understood as cumulated value of profit) is the time factor, related to the term of launching a product, production cycle length and production period.

2. Historical sources of productivity increase

The main source of increasing productivity after the Second World War were automation processes – first hard and then flexible. Despite investing a great deal of financial means in developing systems and achieving initially positive effects, the expected effects of increased work efficiency, in relation to the cost of work and exploitation of workplaces are not satisfactory.

In next decades technological development made the technically advanced enterprises direct on cheaper Japanese socio-technical methods of solving efficiency problems, e.g. according to the idea of lean manufacturing. At the end of 20th century it turned out that the potential of these methods is diminishing and using them further may only bring partial efficiency increments in particular phases of the production process. This caused undertaking action aimed at delocalising production, relocating manufacturing processes to countries with cheaper workforce. Examples of applied methods of manufacturing delocalisation were presented in Fig. 1 [3, 4].

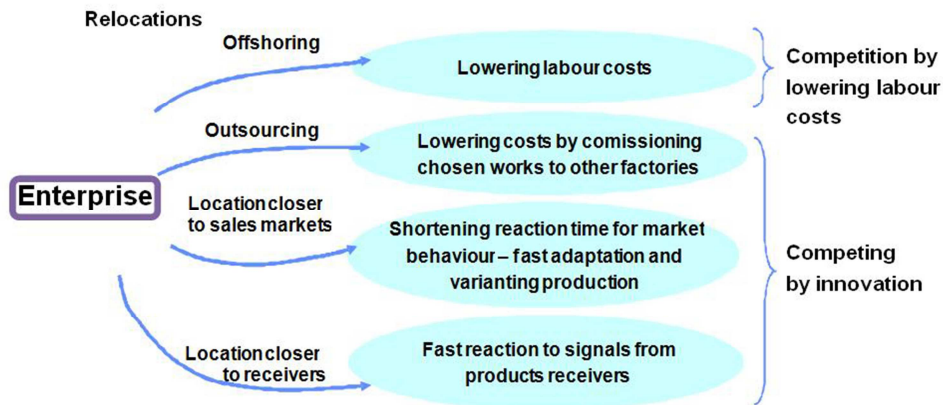

Fig. 1. Relocating manufacturing processes

3. Digital enterprises, digitalisation and integration of production activities

In the area of research and development in automotive, electrotechnical, aviation and cosmic industries completely new approaches to designing and testing products and production processes have appeared. The approach is characterised by using fast prototyping methods, digitalisation of processes to be realised in the future, and simulating their virtual process [5].

New technologies are an indirect element between the CAx systems used so far and the ERP class software (Fig. 2). Integration of these systems emerged new possibilities for the processes of production systems design and shaping. New terms appeared as well, like the notion of a “digital factory” (DF), or digital factory management.

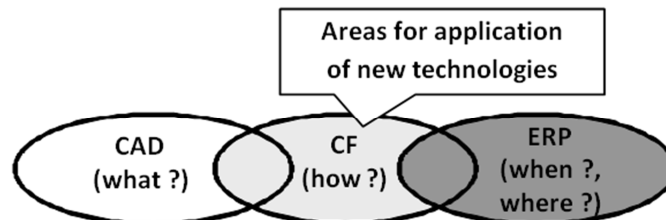

Fig. 2. The area of interest of the software related to the notion of ‘digital factory’

Virtual reality penetrates to all areas of enterprise activity. It finds application in designing workplaces, processes, production systems, work

positions, planning systems, production management, etc. the concept of a digital enterprise is based on three elements (Fig. 3) [6]:

- product digitalisation with aspects of static and dynamic features of its properties,
- digital planning of a workplace and the production system,
- digital modelling and simulation of a virtual course of production, with possibility of using the obtained data to building real production systems.



Fig. 3. An example of modelling work on a position of assembly

The main methods using the technology of a digital factory are computer simulations, which are supported by experts. The development of applying different simulation methods is illustrated in Fig. 4. Research in this area of production engineering is carried out in Production Engineering Departments at the University in Zilina (Slovakia) and the University of Bielsko-Biała.

Simulation systems, such as for example ARENA, offer a comprehensive set of advanced solutions designed to analyse the manufacturing processes realized in production enterprises. The range of uses cover the whole production process, from designing and production preparation, manufacturing and planning of machines' setup, to assembly and sale of final products (Fig. 5) [7-10].

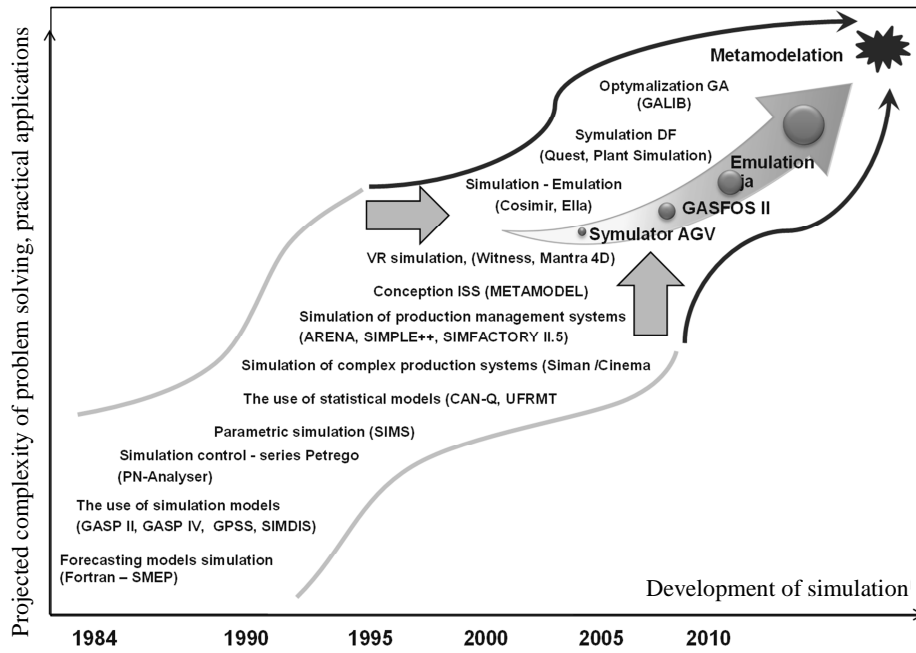

Fig. 4. Development of simulation methods [7]

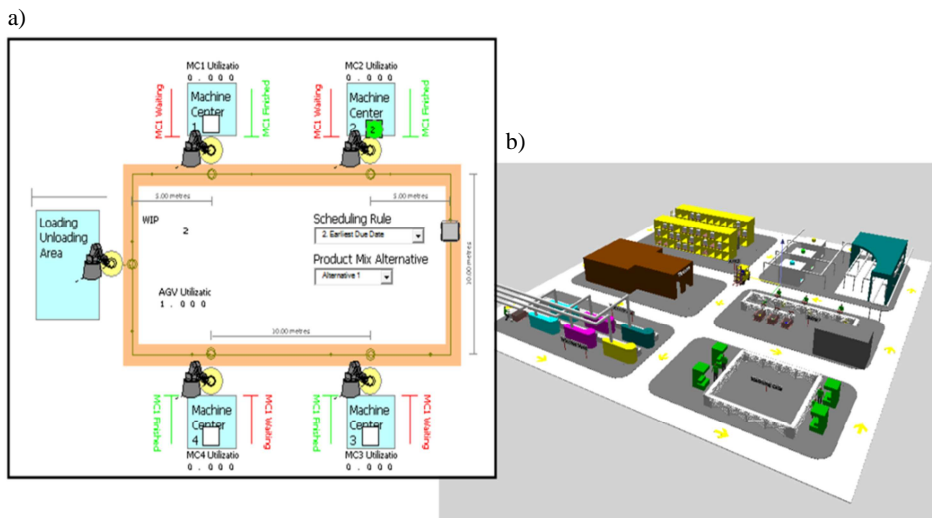

Fig. 5. 2D (a) and 3D (b) simulation model [8]

4. Example of the production line improvement

4.1. Characterization of the analysed production system

A production process is the chain of activities, which are realized on mutually related resources and often only several workplaces (units) in this system have influence on the achieved result (constraints). Understanding of these dependence makes possible to find solution even for very complicated problems of production management.

The improvement of the production system should be realized in a cyclic way in 5 following stages:

- 1 – identifying of the constraint (bottleneck) of the system,
- 2 – maximum exploitation of the present possibilities of the bottleneck,
- 3 – subordination of all to the maximum utilization (exploitation) of the bottleneck,
- 4 – elevation of the bottleneck possibility (throughput),
- 5 – return to the stage 1.

The main goal of the conducted analysis was to increase volume of production in the crankshafts' machining line. The analyzed line works in 3-shift system and 6 days per week, what excludes possibilities of increasing efficiency by introduction of additional shift or extra hours.

Main attention in this analyze was given on the setup process in the machining centre, which proved to be the bottleneck of the analyzed line. With use of simulation it is possible to check different variants of possible ways of machines' setup and to choose the best for realization – variant with the highest volume of production.

Now this workplace is modernized. It will allow to achieve shorter breaks for setup and shorter process time of realized operations, average about 5% for every part. This activity is a typical example of realization of the fourth step in TOC (elevation of the bottleneck possibility).

4.2. Constraint identifying

After modelling of work in the crankshaft machining line (Fig. 6) and simulation of weekly production in reports from simulation, there were information about duty of workplaces, about size of queues before workplaces and achieved volume of production. It made possible identifying of the bottleneck.

The bottleneck of the analysed production system is the machining centre for operation number 140 characterized by the largest duty and the largest number of waiting pieces in the queue. This operation has the longest operation time and the longest setup times.

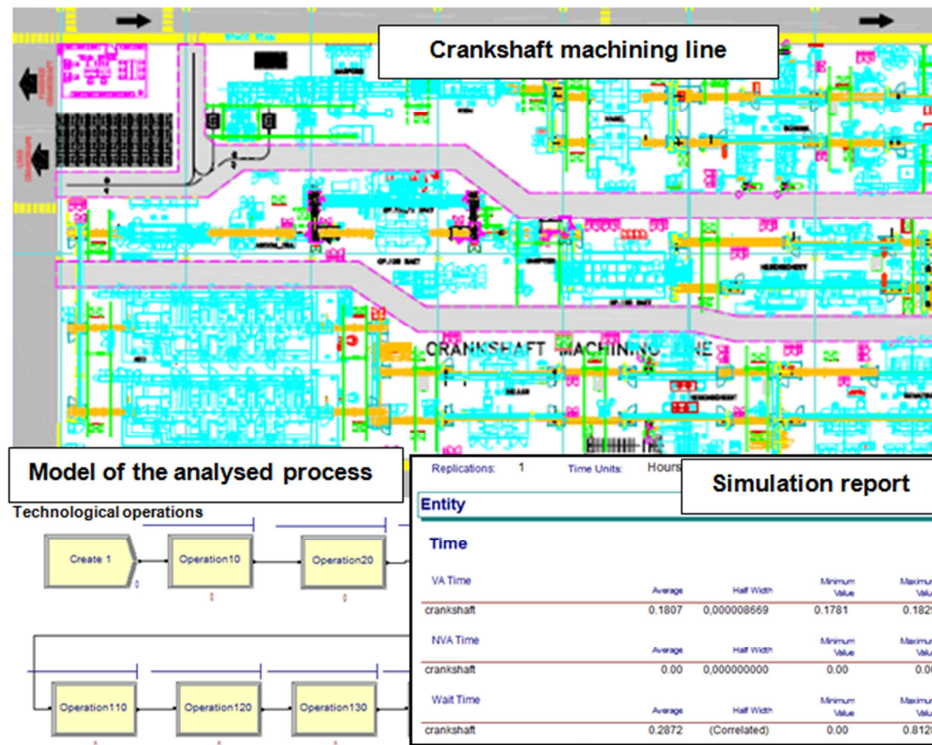

Fig. 6. Simulation model of the crankshaft machining line

4.3. Maximum exploitation of the present possibilities of turning machines

To enlarge the efficiency of machining centre there were proposed organizational changes. The creation of conditions for continuous production in this workplace was the effect of these changes. In the bottleneck always will be worked the least one operator. The machining centre will be supported additionally by the operator from neighbouring workplaces.

Above mentioned changes were introduced into the second simulation model. From the conducted simulation there were drawn out the following conclusions:

- duty of all workplaces of the analysed production line grew up – average about 2%. The bottleneck was loaded almost 100%,
- the volume of production grew up similarly – from 18200 to 18600 pieces (about 2%).

4.4. Subordination of production planning to maximum exploitation of the bottleneck

This principle was realized by the proper scheduling of production orders. In the first simulation the size of batches of material was established on the level of 20000 parts per week. How it turned out from simulation, we are not able to process such quantity of material. In effect, this guided to enlarging queues before machining centre (bottleneck). On the basis of results from simulation, there was established, that 18600 pieces will be the suitable size of week's batch of production. With such level of production the average week's size of the queue before bottle-neck will be constant.

4.5. Elevation of the bottleneck throughput

The efficiency of the machining centre should be enlarged by purchase of a new machine. This solution was rejected – too large costs of investment.

There were proposed organization changes connected with tools' exchange, which aim was the shortening of time of machine standstill during setup.

In the analyzed workplace there are 15 machining units, which work in different cycles of tools exchange. The setup of any machining unit requires to stop of the whole line and it often causes standstills. It was the main reason to establish the setup time for units with the same cycle (to minimize quantity of standstills).

With regard to large differentiation working time of tools and their costs, simultaneous setup of all units is not possible. There were proposed several solutions, which were modelled and checked by computer simulation. This simulation was conducted in ARENA packet (Fig. 7).

The most important variants are:

- V1 – current state (one worker sets up all production units in machining centre),
- V2 – second worker's employment (one worker sets up from the left side, and second from the right side of machining centre),
- V3 – engagement of two workers (both workers set up units from the left and the right side of machining centre in dependence on need),
- V4 – new schedule for setup (the change of setup cycles and grouping tools for minimize quantity of standstills).

By simulation there were determined, for defined variants, efficiency of the analyzed units, duty of workers and workplaces. The results from simulation were used to comparison of proposed variants. The best variant was V3 (Fig. 8). The achieved results can be the basis for planning of tool service.

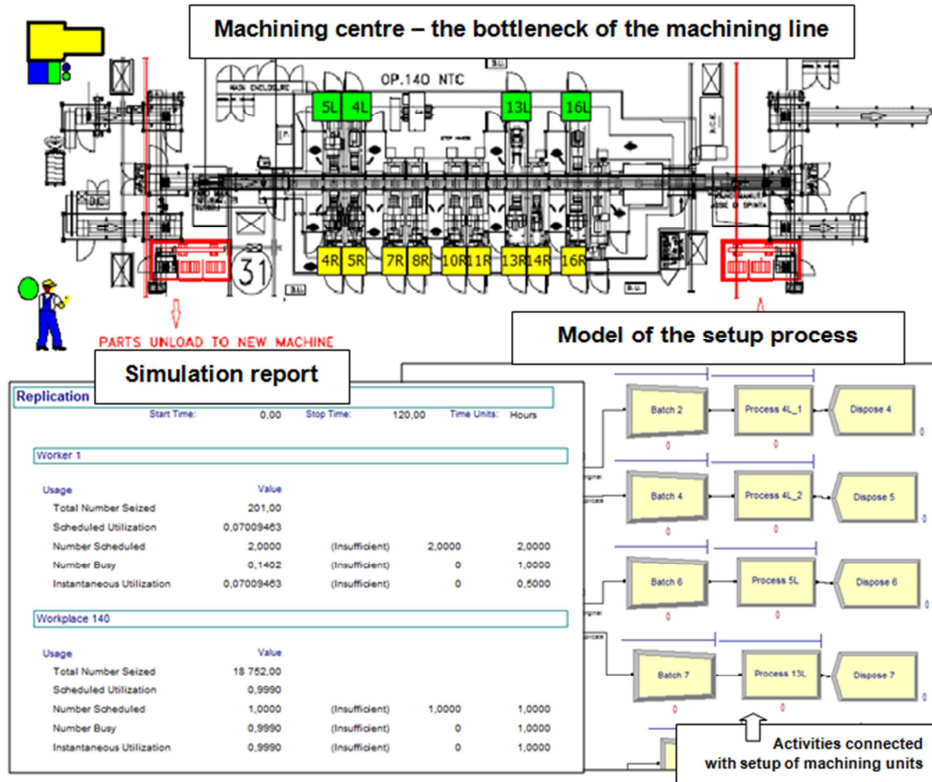

Fig. 7. Simulation model of the exchange of tools in the machining centre

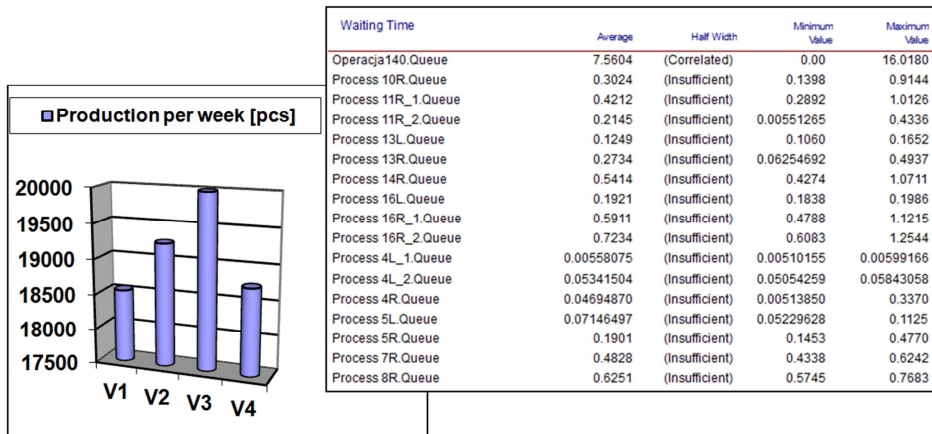

Fig. 8. Example of results from simulation

The achieved volume of production carries out about 20 000 pieces. The duty of workplaces was increased average about 6%. The duty of the analyzed machining centre carries out 98%, what means that we should return to the beginning of analysis, that is to identification and improving of a new constraint of the analysed production system.

5. Conclusions

In the described analysis there were presented only examples of simulation variants. In practice, there are more variants. They can be more detailed and they can taken into account more aspects of the analysed production systems.

The disadvantage of the modelling and simulation is labour-consuming of building models. In the first prepared model, it is possible, comparatively easily, to change its parameters and create next models taking into account other variants of different improvements of the identified constraint. It is possible, in continuous way, to manage constraints – identify, plan loading and check possibility for improving.

The introduced example confirms, that modelling and simulation of production processes becomes more and more important aiding technique, not only for designing of new production systems, but also for continuous improving of already functioning production systems.

Manufacturing processes rationalisation and implementation management traditional tools, like e.g. FMEA, 5S, TPM, SMED, JiT, etc., and use new technologies of a digital factory, like e.g. scanning, modelling and simulation, animation and virtualisation of the production processes may successfully realized production, from the point of view of:

- supporting new products design,
- supporting manufacturing processes design, e.g. designing of workplaces, sockets, production systems, working time norms, production costs estimation, choosing the optimal solution from a few alternative manufacturing process courses,
 - designing logistic activities in enterprises (e.g. interoperational warehouses, material flows inside cooperative systems),
 - supporting decision problems solving in the area of investment.

References

- [1] F. JOVANE, D. WESTKAMPER, E. WILLIAMS: The ManuFuture Road. Towards competitive and sustainable high-adding-value manufacturing. Springer-Verlag, Berlin 2009.

- [2] MANUFUTURE – a vision for 2020. Assuring the future of manufacturing in Europe. Report of the High Level Group, DG Research, European Commission, Brussels 2004.
- [3] Y. KOREN: The global manufacturing revolution. John Willey & Sons, New Jersey 2010.
- [4] M. MONTORIO, M. TAISCH: The future of manufacturing: survey of international technology foresight initiatives. Advanced Manufacturing – An ICT and Systems Perspective. Taylor&Francis, London 2007.
- [5] E. WESTKAMPER, E. ZAHN: Wandlungsfähige Produktionsunternehmen. Das Stuttgarter Unternehmensmodell. Springer-Verlag, Berlin 2009.
- [6] M. GREGOR: ZIMS – Žilinský inteligentný výrobný systém. CEIT, Žilina 2011.
- [7] M. GREGOR: Operačný manažment I-II. Žilinská univerzita, Katedra priemyselneho inžinierstva, Žilina 2010.
- [8] Training materials for ARENA software.
- [9] M. DOBRZYŃSKI, W. PRZYBYLSKI: Simulation research on the tool cycle in automated manufacturing system at selected tool duplication levels. *Advances in Manufacturing Science and Technology*, **36**(2012)3, 55-66.
- [10] W. GRZESIK, P. NIESŁONY, M. BARTOSZUK: Modelling of the cutting process – analytical and simulation methods. *Advances in Manufacturing Science and Technology*, **33**(2009)1, 5-29.

Received in October 2012