

# Photonic integrated circuits – a new approach to laser technology

R. PIRAMIDOWICZ<sup>1\*</sup>, S. STOPIŃSKI<sup>1,2</sup>, K. ŁAWNICZUK<sup>1,2</sup>, K. WELIKOW<sup>1</sup>, P. SZCZEPAŃSKI<sup>1</sup>,  
X.J.M. LEIJTENS<sup>2</sup>, and M.K. SMIT<sup>2</sup>

<sup>1</sup> Institute of Microelectronics and Optoelectronics, 75 Koszykowa St., 00-662 Warszawa, Poland

<sup>2</sup> COBRA Research Institute, Eindhoven University of Technology, P.O. Box 513, 5600 MB Eindhoven, Netherlands

**Abstract.** In this work a brief review on photonic integrated circuits (PICs) is presented with a specific focus on integrated lasers and amplifiers. The work presents the history of development of the integration technology in photonics and its comparison to microelectronics. The major part of the review is focused on InP-based photonic integrated circuits, with a short description of the potential of the silicon technology. A completely new way of fabrication of PICs, called generic integration technology, is presented and discussed. The basic assumption of this approach is the very same as in the case of electronic circuits and states that a limited set of standard components, both active and passive, enables designing of a complex, multifunctional PIC of every type. As a result, functionally advanced, compact, energy efficient and cost-optimized photonic devices can be fabricated. The work presents also selected examples of active PICs like multi-wavelength laser sources, discretely tunable lasers, WDM transmitters, ring lasers etc.

**Key words:** integrated optoelectronics, laser technology, photonic integrated circuits, indium phosphide.

## 1. Introduction

It is well known that the rapid development of integrated electronics, observed in the past decades, started from very simple analog systems, consisting of a number of separate, discrete components, such as resistors, capacitors and transistors. The resulting devices occupied considerable space and were consuming high amounts of electrical power. Also the reliability was a serious problem. The situation changed with the advent and further development of monolithically integrated circuits, which revolutionized the way of thinking about electronic circuits. The next major breakthrough was the establishment of the CMOS (Complementary Metal-Oxide-Semiconductor) technology standard. Rapid progress of the CMOS capabilities enabled mass production of functionally advanced and relatively cheap electronic integrated circuits (ICs). The evolution of complexity of CMOS circuits follows Moore's law, which states that the number of transistors on integrated circuits doubles every two years. Nowadays, chips integrating even milliards of elements are fabricated.

Simultaneously, the miniaturization of electronic devices and development of integration technology enabled production of multi-functional, energy efficient, compact and portable devices, which may be effectively operated with small-size batteries. A good example is the modern cell phone with computational power far higher than early supercomputers. All these factors caused that silicon-based ICs are now ubiquitously applied in every field of technology and everyday life.

A similar trend to miniaturization and integration is observed in the semiconductor photonics industry. The rapid development of semiconductor-based photonic devices started with the invention of the light emitting diode (LED) in

1955 [1] and semiconductor laser diode (LD) operating at room temperature in 1970 [2]. The operating principle of these components is based on radiative recombination of the carriers within the forward-biased p-n diode made of direct band-gap materials, which allows emission of light, amplification and/or lasing (depending on the structure and materials used). After four decades of continuous development LEDs and LDs are key elements in modern telecommunication, data storage and data processing systems, optical sensors and sensing networks, image processing systems etc. The progress in semiconductor light sources was accompanied by intensive research and development of other optical components – light modulators, detectors, low-loss waveguides, couplers and (de) multiplexers etc. At present, all of these elements are available in integrated form. It should be noted here that from the point of view of integrated solutions – the invention of the semiconductor optical amplifier (SOA) [3] was a real breakthrough, enabling both amplification of the optical signals with gain as high as 30 dB [4] and design of various types of integrated semiconductor lasers, described in the following part of this paper.

Apart from impressive results obtained up to now in integrated photonics the choice of an optimal technology is still an open issue. In general, two main approaches are being developed in parallel – the first is based on silicon technologies while the second is focused on group III-V semiconductors. This work is focused on the second approach, however our intention was to provide also brief information on silicon photonics.

**1.1. Silicon photonics.** When considering integration of several functionalities on a single chip, the silicon platform is

\*e-mail: r.piramidowicz@imio.pw.edu.pl

an obvious choice, as it has already demonstrated fabrication of very large scale (electronic) integrated circuits. It is well known that the CMOS technology is mature, reliable and relatively cheap. What is more, it offers a very attractive possibility for integrating both photonic and electronic functionalities. A significant drawback of silicon, however, is its indirect band-gap which prevents effective amplification and generation of light. Despite the fact that presently it is limited to passive functionalities, the silicon technology platform for photonics has been extensively developed [5], offering high performance, good process control and low cost of fabrication for photonic integrated circuits.

Another approach was proposed by Intel Corporation, as an outcome of extensive research on optical data transmission inside the computers, servers and data centers, as the traditional, copper-based solutions have been reaching the theoretical speed limits. Intel presented AlGaInAs based hybrid laser integrated on a silicon chip which consists of waveguides, amplitude modulators and an output multiplexer [6]. This solution combines the advantages of both AlGaInAs (active material) and silicon (good passive properties, low-cost and mature fabrication technology). The result is a 50 Gb/s photonic data link consisting of a hybrid-integrated transmitter and a fully-silicon receiver [7].

It should be noted that Intel achieved also laser action in silicon itself, using Raman effect and cascaded operation scheme, in which one laser line acted as the pump for the next one [8]. However, this device required an external optical pumping, therefore not suitable for monolithic integration.

**1.2. InP-based photonics.** As an alternative to silicon for fabrication of photonic integrated circuits, that also supports integration of active components like lasers and optical amplifiers, indium phosphide (InP) based compounds are discussed. These manifest excellent electro-optical properties, such as a direct band-gap that allows efficient light generation and detection, light guiding and fast phase modulation. Moreover, the emission wavelength of the ternary (InGaAs, InAlAs) and quaternary (InGaAsP, AlGaInAs) compounds can be tuned over a wide spectral range between 0.92  $\mu\text{m}$  and 1.65  $\mu\text{m}$  [9], depending on the composition of the elements. Simultaneously, the lattice constant can be matched with InP, so that the epitaxial growth of these compounds onto an InP substrate is possible.

Effective integration on a single platform of both passive and active components is a great advantage of the InP based technology. Invention of the arrayed waveguide grating (AWG, alternatively named PHASAR) in 1988 [10] started the era of wavelength division multiplexing (WDM) photonic integrated circuits. The number of components in a single chip has been continuously increasing, reaching now several hundreds of components. Examples of already demonstrated large-scale photonic integrated circuits are arrayed waveguide grating (AWG) based multi-wavelength lasers [11, 12], DBR (distributed Bragg reflector) and DFB (distributed feedback) based WDM transmitters [13, 14], filtered-feedback based WDM lasers [15], mode-locked lasers [16], WDM ring lasers

[12], quantum-dot based lasers for optical coherence tomography [17], tunable lasers with integrated wavelength converters [18], integrated receivers [19], optical time domain multiplexers [20] and many others.

However, even though many InP-based large-scale photonic integrated circuits have been demonstrated already, the commercial success is still limited. Nowadays the market offer covers circuits which integrate relatively small number of components. The only truly large-scale photonic integrated circuit, which is commercially available, is the 100 Gb/s transmitter developed by Infinera Corporation [14], integrating ten DFB lasers, electro-absorption modulators (EAMs), power monitors (OPMs), variable attenuators (VOAs) and an output AWG multiplexer.

At the moment, photonic integration is considered as one of the most promising technologies for fabrication of functionally advanced, compact and cost-effective devices. Generally, photonic integrated circuits (PICs), compared to their free space or fiber optic equivalents, offer advantageous performance in terms of size and weight, energy consumption, efficiency and reliability. On the other side, they can replace electronic devices which perform the same functionality, with a higher operation speed and bit-rate, while consuming less energy. Undoubtedly, the major driver of the development of the photonic ICs is the telecommunications market. However, the devices based on this concept have potential applications in other fields, like fiber sensors, medical diagnostics, metrology or switching in photonic interconnects in computer backplanes.

## 2. Generic integration technology

In order to achieve the broad application of photonic integrated circuits novel, more efficient methods for their fabrication are required. One of the most promising solutions is generic integration technology [21]. The primary assumption of this approach is that complicated photonic devices can be divided into basic building blocks (BBs) such as a waveguide, a phase modulator and an amplifier. Additionally, it is assumed that complex components (e.g. splitters, couplers, filters) and whole circuits can be obtained as a combination of these fundamental elements. In order to obtain high yield the technology processes are standardized and general design rules are defined for all designers. In this approach it is crucial to guarantee the performance of every BB by maintaining its characteristic parameters, for example attenuation/losses of the waveguides, phase shift in modulators, gain in amplifiers.

There is a clear analogy to CMOS technology, where complex ICs are designed using limited number of fundamental blocks, the parameters of which are specified by foundries individually.

The concept of InP-based generic technology in photonics has been developed since 2006 in the JePPIX platform (Joint European Platform for InP-based Photonic Integrated Components and Circuits) [22, 23]. The set of basic building blocks for this platform consists of shallow and deep etched passive waveguides, a waveguide with a top cladding removed

for electrical isolation, an electro-optical phase modulator and a semiconductor optical amplifier. Figure 1 presents the SEM pictures of the BBs fabricated in the COBRA Research Institute [13, 23]. By using these basic elements, other composite building blocks can be designed and fabricated. The most important examples of such advanced BBs were presented and discussed below.

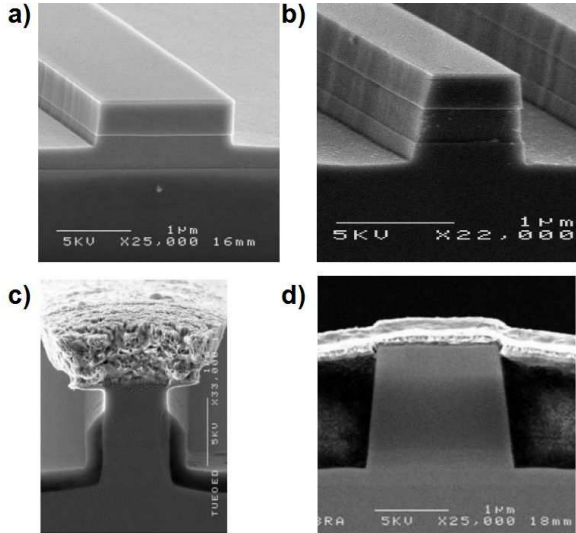

Fig. 1. SEM pictures of the basic building blocks of the COBRA process [12, 22] a) shallowly etched waveguide b) deeply etched waveguide c) phase modulator d) semiconductor optical amplifier

**2.1. MMI based devices.** One of the most commonly used components are the MMI-based (Multi-Mode Interference) devices [24, 25]. An MMI section is a piece of a straight waveguide wide enough to support propagation of more than one mode. The principle of operation is based on the cyclic interference of the waveguide modes, due to their different propagation constant. By properly positioning the inputs and outputs of the section, one can design various devices, such as mode filters,  $1 \times N/N \times 1$  power splitters/combiners,  $N \times M$  power couplers and splitters with asymmetric splitting ratio [26]. Furthermore, the MMI effect can be used for design of reflectors with a high reflection coefficient [27]. The mentioned functionalities of the MMI components are illustrated in Fig. 2.

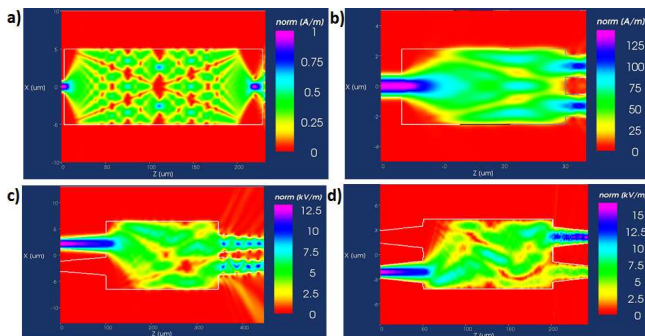

Fig. 2. MMI-based components a) general MMI structure b)  $1 \times 2$  (3 dB) power splitter c)  $2 \times 2$  (3 dB) power coupler d) power splitter with asymmetric (85%:15%) splitting ratio. Acknowledgement to PhoeniX Software BV for the license

**2.2. AWG multiplexer.** Combination of a slab waveguide and an array of deeply-etched waveguides can form a wavelength (de)multiplexer, called AWG – arrayed waveguide grating [10, 28]. The principle of operation, schematically depicted in Fig. 3, is based on introducing a phase difference among the signals propagating through various arms of the array. The optical field at the input diverges in the first free propagation region (FPR), which is a piece of slab waveguide, and gets coupled to the arrayed waveguides. The length of each arm is equal to an integer multiple of the central wavelength ( $\lambda_c$  – a parameter of the multiplexer). As a result, the signals carried in  $\lambda_c$  have equal phase at the output of the arrayed waveguides so that this channel is focused in the center of the second FPR. However, other channels are focused in different points, next to the central channel, as their phase front is tilted due to the different lengths of the arrayed waveguides. The AWG provides spatial (de)multiplexing of the WDM signals. It is a reciprocal device, which acts as a multiplexer in one direction and as a demultiplexer in the other.

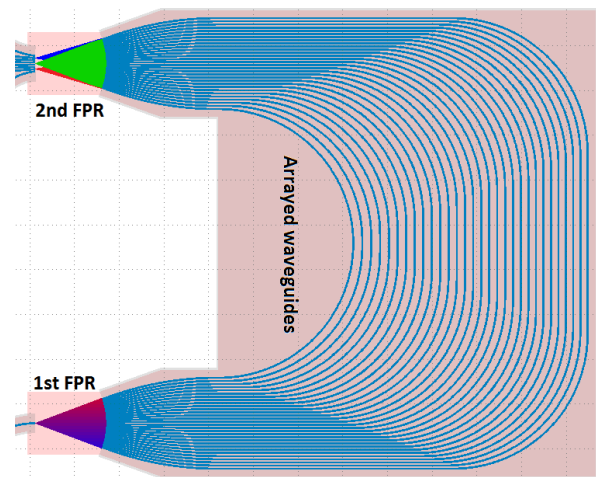

Fig. 3. AWG principle of operation – the light is coupled to the arrayed waveguide, phase difference at the output causes tilting of the phase front so that the various wavelength channels are focussed in different spatial positions

**2.3. Mach-Zehnder amplitude modulator.** Mach-Zehnder amplitude modulators are obtained as a combination of a 3dB power splitter, two phase modulation sections and a power combiner. The SEM picture of such a structure, together with an example of static power transmission characteristics versus driving voltage is presented in Fig. 4. The voltage applied to one of the modulator arms causes a phase change of the optical signal. As a result, the interference of the two signals at the output can be switched between either constructive (full transmission, logical “one”) or destructive (total extinction, logical “zero”). As the power transmission characteristic has a sinusoidal shape, it is also suitable for analog modulation, while operating in the linear region. Alternatively, instead of combining the two arms with a power coupler, the phase shifter arms may be terminated with reflectors, what would form an amplitude modulator in Michelson interferometer configuration.

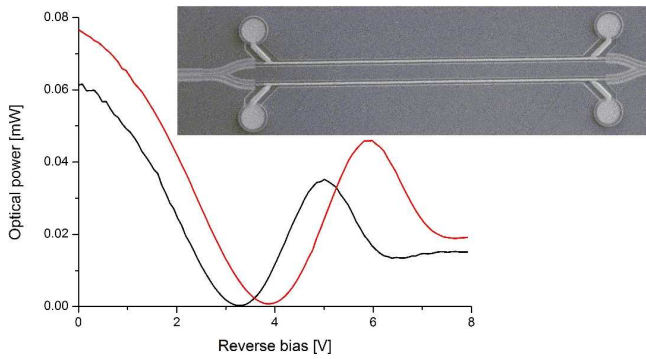

Fig. 4. SEM photograph of the Mach-Zehnder modulator and example of a power transmission characteristic as a function of voltage applied to one of the arms

**2.4. 2 × 2 Switch.** When the Mach-Zehnder modulator structure is modified so that splitters/combiners are replaced by 2x2 power couplers the resulting block acts as a 2x2 integrated optical switch. In this case the phase change in one of the arms causes a continuous flow of the power from one output port to another. Under digital modulation with a proper voltage ( $V_{\pi}$  – causes the phase change with a factor of  $\pi$ ) it will discretely switch the signal between the output ports.

### 3. Selected examples of ASPICs (Application Specific Photonic Integrated Circuits)

One of the most important applications for InP-based photonic integrated circuits are laser sources of different functionalities. Again, the major drivers for the development of InP-based PICs are the WDM telecommunication systems, which require highly effective, tunable light sources compliant with

the ITU grid. Photonic integration helps with providing lasers that can generate several wavelengths simultaneously and can be (discretely) tuned. Such lasers exist in various configurations, described briefly below.

**3.1. AWG-based WDM lasers.** The simplest structure forming a WDM laser source is an array of SOAs combined with an output multiplexer [11, 12]. The resonator is defined by the Fresnel reflections at the chip-air interface. Additionally, the facet can be coated to increase the reflection coefficient. The AWG is not only a multiplexer but acts also as an intra-cavity filter so that the generated wavelengths depend on its pass-band. The discrete tuning is obtained by turning on and off the proper SOAs. It can operate both in a single and a multiple wavelength mode, depending on the number of simultaneously biased SOAs. Additionally, a booster amplifier can be applied in order to increase the generated output power. Figure 5 presents an example of an 8-channel multi-wavelength laser together with the measured lasing spectrum [11]. An alternative solution is shown in [29]. The gain section is on the other side of the AWG (in the place of the booster), and the SOAs in the array are very short – they are not used to amplify the signal, but as optical gates to turn on and off the individual laser channels.

A more complicated configuration has been proposed in [30]. The resonator is formed by an  $N_1 \times N_2$  AWG with  $N_1 + N_2$  amplifiers (in this specific case,  $N_1 = 5$ ,  $N_2 = 8$ ). As a result forty ( $N_1 \times N_2$ ) wavelengths can be generated, depending on which combination of two amplifiers is biased at the same time. The output signal is tapped from the resonator by one of the arrayed waveguides of the AWG. The output signal is amplified by a booster to increase the output power.

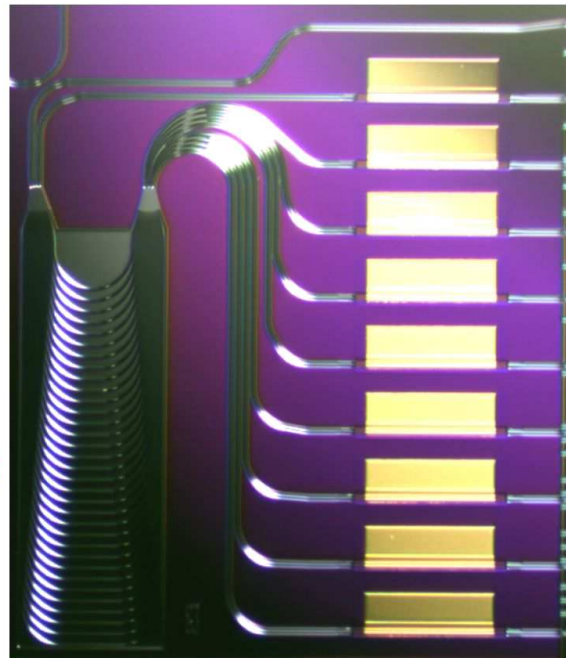
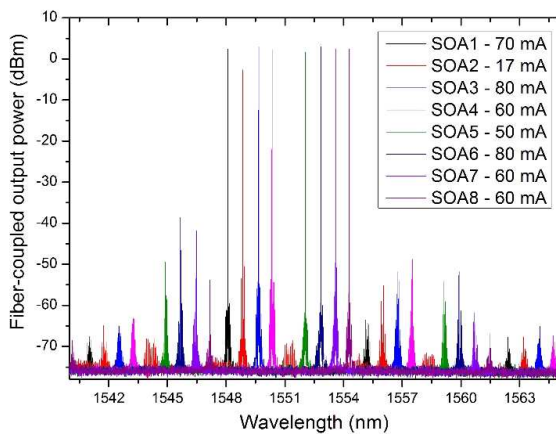

Fig. 5. Photograph and emission spectrum of 8-channel multiwavelength laser with a booster amplifier after Ref. 11

**3.2. Ring lasers.** AWG based lasers may also operate in a ring resonator architecture. An example of such a device is presented in [13]. It is formed by a  $4 \times 4$  AWG and four SOAs which are placed in loops connecting the inputs and outputs of the AWG. The power tapping is done by using two of the arrayed waveguides – one for clockwise and the other for counter clockwise laser signals. When the SOAs are individually biased, they generate single wavelengths. Biasing of two SOAs causes single-channel operation at slightly shifted wavelengths.

**3.3. Filtered-feedback lasers.** Some of the integrated lasers utilize standard, Fabry-Perot type resonators [15]. Complementing these with some additional components, like an AWG and a phase shifter, enables to lock the laser at a specific wavelength, so called filtered-feedback operation. Figure 6 shows a scheme and a photograph of such a filtered-feedback laser. Apart from the laser itself, there are four Mach-Zehnder modulators added for generation of digital signals. In this case the four channels are not multiplexed to a single output. The chip has four independent outputs, each of them operating at different wavelength.

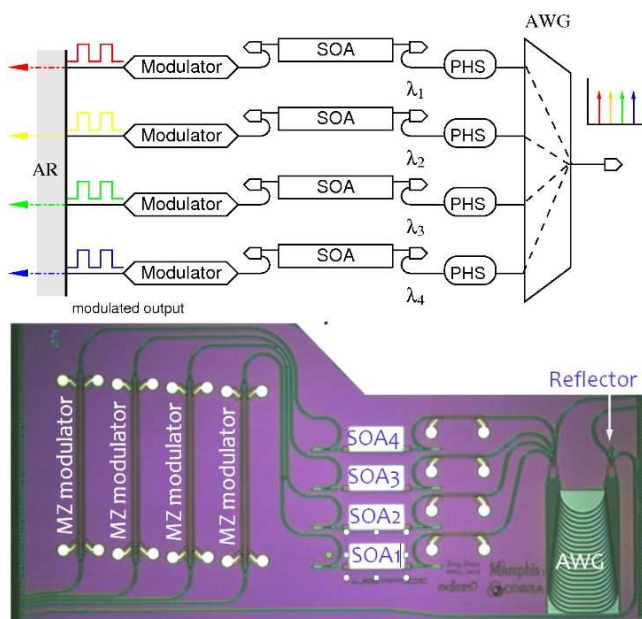

Fig. 6. 4-channel, filtered-feedback WDM laser/transmitter after Ref. 15. It is a Fabry-Perot type resonator with extended cavity, where additional filtering (by AWG) and tuning (by phase shifters) is applied. Mach-Zehnder modulators are for digital signal generation.

Acknowledgement to Jing Zhao for the picture

**3.4. WDM transmitters.** The AWG is not the only way of filtering of the longitudinal laser modes. The transmitter chip manufactured by Infinera Corporation [14] (mentioned in the introduction) consists of an array of DFB lasers and the selection of the wavelength is done by means of a distributed feedback resonators. The AWG in this circuit does not select the laser modes, but multiplexes the ten digital signals generated by the DFB lasers followed by electro-absorption modulators. A similar approach has been shown in [13]. However,

in this case the lasers are built with SOAs and tunable Bragg gratings (building blocks offered by Oclaro Ltd. in a multi project wafer run). The difference, in comparison to the Infinera chip, is that this circuit generates four digital signals and four CW signals (instead of only digital). Figure 7 presents a photograph of a chip with such transmitters implemented.

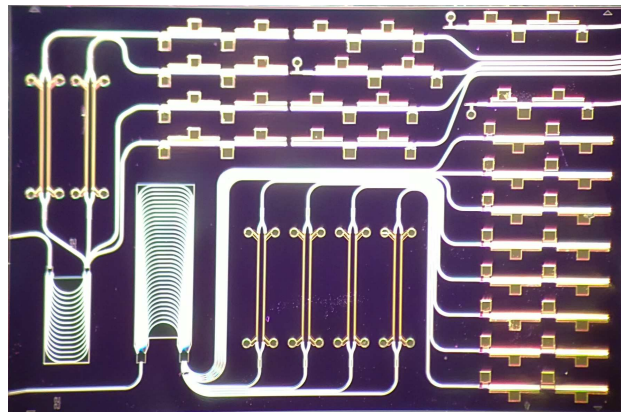

Fig. 7. FTTH transmitters after Ref. 13. The 8-channel circuit comprises an array of eight DBR lasers (right side of the chip). Four channels are digitally modulated by Mach-Zehnder modulators (downstream), four channels provide CW power for the upstream signals

**3.5. Mode-locked lasers.** Integration technologies enable also design and manufacturing of pulsed sources. The good example is the device presented in [16] – mode-locked laser with a tunable repetition rate. Its fundamental rate is 14 GHz, however, as the device has a Mach-Zehnder modulator following the laser, some of the pulses can be extinguished by proper modulation of the modulator (gating), thus decreasing the repetition rate of the whole laser system.

## 4. Summary

Photonic integrated circuits are definitely one of the most promising solutions for the next generation of optoelectronic devices. Their main advantages – compact size, energy efficiency, high speed operation and low cost large-scale fabrication are analogous to the electronic ICs. In recent years the fabrication technology of integrated photonic devices has been significantly developed and nowadays chips consisting of hundreds of elements can be manufactured. However, lack of a standard fabrication and packaging technology still hampers the development and commercial application of PICs. In comparison to microelectronics, integrated photonics has not yet penetrated the commercial market on a large scale. There is a lot of impressive results, but rather of the scientific, than commercial value. It is obvious that at present the main factor limiting development of PICs is the cost of technology. That is why the leading European centres of integrated photonics are located in the western part of Europe, having advanced technological facilities at their disposal. It should be noted, however, that despite technological limitations the research on this subject are also carried by several Polish groups [33, 34].

It is believed that the generic integration concept, being developed and tested by the JePPIX platform may bring a significant technological breakthrough and completely change the state of photonic market. At present two large European FP7 projects, which combine the scientific and technological potential of key European players are focused on establishing a generic manufacturing chain in InP-based photonics. The first one is EuroPIC (European Manufacturing Platform for Photonic Integrated Circuits) [31], which was launched in August 2009 and completed in July 2012. The second one is PARADIGM (Photonic Advanced Research and Development for Integrated Generic Manufacturing) [32], launched in October 2010, which will continue until September 2014.

Elaboration of the manufacturing chain requires achievement of several objectives – developing and providing all users with unified building blocks (both basic and composite), developing professional software for simulations of the circuits and mask designing, with implemented tools for design rule checking, and, finally, determine the standard for packaging. Then, the foundries have to provide on-wafer verification of the manufacturing process. One of the means to provide low-cost access to the advanced photonic technology is a multi-project wafer (MPW) run – an idea taken from microelectronics. Its main assumption is that the cost of the foundry run is shared among the users, who pay for the circuits proportionally to the occupied area. The MPW run concept allows for reduction of research and development as well as prototyping costs of novel devices. It has been extensively tested and used in microelectronics [35, 36] and now this idea is being applied in photonics [21, 22]. First MPW runs have already been performed in the framework of both projects at Oclaro Ltd. (UK) and at the Fraunhofer Heinrich Hertz Institut (Germany). Additionally, the COBRA Research Institute at Technische Universiteit Eindhoven (the Netherlands) also performed six MPW cycles independently.

In September 2011 the Warsaw University of Technology joined the PARADIGM project. One of the main tasks of its activity is the establishment of a design centre for Poland and neighboring countries – the Eastern Europe Design Hub. This will be a contact point and design provider for commercial companies, research institutes and universities from Eastern and Central-Eastern parts of Europe.

**Acknowledgements.** Authors of this paper are members of the PARADIGM consortium, developing the generic manufacturing chain (funding from the European Community's Seventh Framework Programme FP7/2007-2013 under the grant agreement ICT 257210 PARADIGM).

## REFERENCES

- [1] R. Braunstein, "Radiative transitions in semiconductors", *Physical Review* 99 (6), 1892–1893 (1955).
- [2] Z.I. Alferov, V.M. Andreev, D. Garbuzov, and Y.V. Zhilyaev, "Investigation of the influence of the AlAs-GaAs heterostructure parameters on the laser threshold current and realization of continuous emission at room temperature", *Sov. Phys.Semiconductor* 4 (9), 1573–1575 (1971).
- [3] J.W. Crowe and R.M. Craig Jr., "Small-signal amplification in GaAs lasers", *Appl. Phys. Lett.* 4, 57–58 (1964).
- [4] G. de Valicourt, D. Maké, J. Landreau, M. Lamponi, G. H. Duan, P. Chanclou, and R. Brenot, "High gain (30 dB) and high saturation power (11 dBm) RSOA devices as colorless ONU sources in long-reach hybrid WDM/TDM-PON architecture", *IEEE Photonics Technology Letters* 22 (3), 191–193 (2010).
- [5] The Silicon-photonics platform ePIXfab, [www.epixfab.eu](http://www.epixfab.eu).
- [6] A. Fang, H. Park, O. Cohen, R. Jones, M. Paniccia, and J. Bowlers, "Electrically pumped hybrid AlGaInAs-silicon evanescent laser", *Optics Express* 14 (20), 9203–9210 (2006).
- [7] Intel Labs website, [www.intel.com/go/sp](http://www.intel.com/go/sp).
- [8] H. Rong, R. Jones, A. Liu, O. Cohen, D. Hak, A. Fang, and M. Paniccia, "A continuous-wave Raman silicon laser", *Nature* 433, 725–728 (2005).
- [9] G. Keiser, *Optical Fiber Communications*, McGraw-Hill, New York, 2000.
- [10] M.K. Smit, "New focusing and dispersive planar component based on an optical phased array", *Electronics Letters* 24 (7), 385–386 (1988).
- [11] K. Lawniczuk, R. Piramidowicz, P. Szczepanski, P.J. Williams, M.J. Wale, M.K. Smit, and X.J.M. Leijtens, "8-channel AWG-based multiwavelength laser fabricated in a multi-project wafer run", *Proc. 23rd Int. Conf. on Indium Phosphide and Related Materials* 1, CD-ROM (2011).
- [12] J.H. den Besten, "Integration of multiwavelength lasers with fast electro-optical modulators", *PhD Thesis*, Eindhoven University of Technology, Eindhoven, 2004.
- [13] K. Lawniczuk, M.K. Smit, X.J.M. Leijtens, M.J. Wale, R. Piramidowicz, and P. Szczepanski, "Photonic integrated multiwavelength transmitters for Fiber-To-The-Home networks", *Proc. 16th Eur. Conf. on Integrated Optics and Technical Exhibition* 1, CD-ROM (2012).
- [14] R. Nagarajan, "Large-scale photonic integrated circuits", *IEEE J. Selected Topics in Quantum Electronics* 11 (1), 50–65 (2005).
- [15] J. Zhao, K. Dijkstra, M.J. Wale, P. Maat, M.K. Smit, and X.J.M. Leijtens, "Monolithically integrated filtered-feedback multi-wavelength laser with Mach-Zehnder modulators", *Proc. 16th Eur. Conf. on Integrated Optics and Technical Exhibition* 1, CD-ROM (2012).
- [16] X. Guo, "Monolithically integrated variable repetition rate mode-locked laser diode", *Proc. 16th Eur. Conf. on Integrated Optics and Technical Exhibition* 1, CD-ROM (2012).
- [17] B.W. Tilma, "Integrated tunable quantum-dot laser for optical coherence tomography in the 1.7  $\mu\text{m}$  wavelength region", *IEEE J. Quantum Electronics* 48 (2), 87–98 (2012).
- [18] R.G. Broeke, J.J.M. Binsma, M. van Geemert, F. Heinrichsdorff, T. van Dongen, J.H.C. van Zantvoort, X.J.M. Leijtens, Y.S. Oei, and M.K. Smit, "An all-optical wavelength converter with a monolithically integrated digitally tunable laser", *Proc. 28th Eur. Conf. on Optical Communication* 1, CD-ROM (2002).
- [19] E. Pennings, "III-V integration roadmap", *MIT Roadmapping Conf.* 1, CD-ROM (2004).
- [20] S. Stopiński, M. Malinowski, R. Piramidowicz, M.K. Smit, and X.J.M. Leijtens, "Integrated optical serializer designed and fabricated in a generic InP-based technology", *Proc. 16th Eur. Conf. on Integrated Optics and Technical Exhibition* 1, CD-ROM (2012).
- [21] M. Smit, X. Leijtens, E. Bente, J. Van der Tol, H. Ambrosius, D. Robbins, M. Wale, N. Grote, and M. Schell, "Generic

*Photonic integrated circuits – a new approach to laser technology*

- foundry model for InP-based photonics”, *IET Optoelectronics* 5 (5), 187–194 (2011).
- [22] X. Leijtens, “JePPIX: the platform for InP-based photonics”, *IET Optoelectronics* 5 (5), 202–206 (2011).
- [23] JePPIX technology platform, [www.jeppix.eu](http://www.jeppix.eu).
- [24] L.B. Soldano and E.C.M. Pennings, “Optical multi-mode interference devices based on self-imaging: Principles and applications”, *J. Lightwave Technology* 13 (4), 615–627 (1995).
- [25] M.T. Hill, X.J.M. Leijtens, G.D. Khoe, and M.K. Smit, “Optimizing imbalance and loss in  $2 \times 2$  3-dB multimode interference couplers via access waveguide width”, *J. Lightwave Technology* 21 (10), 2305–2313 (2003).
- [26] M. Bachmann, P.A. Besse, and H. Melchior, “Overlapping-image multimode interference couplers with a reduced number of self-images for uniform and nonuniform power splitting”, *Applied Optics* 34 (30), 6898–6910 (1995).
- [27] E. Kleijn, T. de Vries, H.P.M.M. Ambrosius, M.K. Smit, and X.J.M. Leijtens, *Proc. 15th Annual Symposium of the IEEE Photonics Benelux Chapter 1*, CD-ROM (2010).
- [28] M.K. Smit, “Progress in AWG design and technology”, *Proc. 4th IEEE/LEOS Workshop on Fibres and Optical Passive Components 1*, CD-ROM (2005).
- [29] M.J.R. Heck, A. La Porta, X.J.M. Leijtens, L.M. Augustin, T. de Vries, E. Smalbrugge, Y.S. Oei, R. Nötzel, R. Gaudio, D.J. Robbins, and M.K. Smit, “Monolithic AWG-based discretely tunable laser diode with nanosecond switching speed”, *IEEE Photonics Technology Letters* 21 (13), 905–907 (2009).
- [30] C.R. Doerr, C.H. Joyner, and L.W. Stulz, “40-Wavelength rapidly digitally tunable laser”, *IEEE Photonics Technology Letters* 11 (11), 1348–1350 (1999).
- [31] European FP7 project EuroPIC, [www.europic.jeppix.eu](http://www.europic.jeppix.eu).
- [32] European FP7 project PARADIGM, [www.paradigm.jeppix.eu](http://www.paradigm.jeppix.eu).
- [33] K. Golaszewska, E. Kaminska, T. Pustelny, P. Struk, T. Piotrowski, A. Piotrowska, M. Ekielski, R. Kruszka, M. Wzorek, M. Borysewicz, I. Pasternak, and K. Gut, “Planar optical waveguides for optoelectronic gas sensors”, *Acta Physica Polonica A* 114 (6–A), 221–228 (2008).
- [34] P. Struk and T. Pustelny, “Design and numerical analyses of the planar grating coupler”, *Bull. Pol. Ac.: Tech.* 58 (4), 509–512 (2010).
- [35] The MOSIS service, [www.MOSIS.org](http://www.MOSIS.org).
- [36] Europractice, [www.Europractice.org](http://www.Europractice.org).