

# Prototype of the domestic CHP ORC energy system

J. KICINSKI and G. ZYWICA\*

Institute of Fluid-Flow Machinery, Polish Academy of Sciences, 14 Gen. J. Fiszerza Str., 80-231 Gdansk, Poland

**Abstract.** The Institute of Fluid-Flow Machinery (IMP PAN) in Gdansk pursues its own research in fields such as technologies that use renewable energy sources efficiently, including in particular the small-scale combined heat and power (CHP) systems. This article discusses the design concepts for the prototype of small CHP ORC (organic Rankine cycle) energy system, developed under the research project. The source of heat is a boiler designed for biomass combustion. Electricity was generated using specially designed oil-free vapour micro-turbine. The turbo-generator has compact structure and hermetical casing thanks to the use of gas bearings lubricated by working medium. All energy system components are controlled and continuously monitored by a coherent automation and control system. The article also discusses selected experimental results conducted under laboratory conditions. Thermal-flow tests were presented that allow for an assessment of the operation of energy system components. Additionally, energy performance results of the turbo-generator were given including power obtained at various cycle parameters. The achieved results have shown that the developed energy system operated in accordance with design solutions. Electricity derived from the energy system prototype was around 2 kW, with boiler's thermal power of 25 kW. The research has also confirmed that this system can be used in a domestic environment.

**Key words:** distributed cogeneration, ORC systems, micro-turbines, renewable energy sources.

## 1. Introduction

A CHP ORC energy system is one of the fastest growing technologies of dispersed cogeneration, which allow to simultaneous production of thermal and electric energy on small scale. The popularity of this technology is based, among others, on a very broad scope of applications [1], since it can produce electricity irrespective of heat source used. Depending on local energy resources, the ORC system can cooperate with different types of boilers (biomass-fired, fired with other renewable or non-renewable fuels, or using geothermal or waste heat) and even as a kind of superstructure in bigger energy systems to take full advantage of available thermal energy. Numerous research centers worldwide are being involved in the development of such high quality components or entire energy systems, which is reflected in many publications on this subject. The majority of scientific publications presents the studies conducted on research installations under laboratory conditions. In the power range reaching several kW, commercially available solutions have hardly existed up to now.

The ongoing work is mainly intended to develop this ORC technology to the commercial level. Implementation of the technology is related with the need to overcome technical and economical barriers, which have been highlighted recently in numerous scientific publications. The major technical problem is construction of the expander. It is possible to apply solutions of various type in this power range, including screw expanders, scroll expanders, vane expanders or turbine expanders (vapour micro-turbines). A review of all different types of expanders, mainly units up to 10 kW<sub>el</sub>, which are currently under develop-

ment by industrial and research centers was presented in article [2]. None of the expanders reached series production status. According to the authors of [2], screw and blade expanders have the greatest number of advantages in the power range up to 10 kW<sub>el</sub>. The subject of the study of different types of expanders was the improvement in efficiency. The works are in progress in this scope either through experimental studies [3–6] or numerical calculations [7–11]. Research on expanders is also underway at the IMP PAN, in Gdansk. The up-to-date studies showed, however, that the turbine expanders are the most attractive solutions in a domestic environment [12, 13]. The oil-free vapour micro-turbines are modern and reliable solutions. They do not require an oil lubrication or dynamic seals and are very quiet, compared with other expanders [14]. Due to the high speeds, the micro-turbines are very small-sized. The only rotating element is the rotor with a turbine and a generator, which does not wear out during use if bearing system had been properly designed [15, 16]. They also allow for the achievement of a satisfactory level of flow efficiency reaching 80% [17].

Only very few small ORC systems, among the ones found in the literature, are based on vapour micro-turbines. The main reason for this is the lack of ready-made commercially available solutions and the difficulties concerning the design and precise workmanship of micro-turbine elements. The example of such an installation was discussed in publication [14], but its slow-speed turbine generator (with nominal power 9 kW<sub>el</sub>) was not intended for individual houses and was designed to make use of geothermal sources [18]. The micro CHP biomass-fuelled systems review which may be used, among others, in a domestic environment was presented in [19]. Article [19] also discusses the disadvantages and advantages of different technologies and emphasizes the great potential for growth as far as cogeneration on a small scale is concerned. Experimental

\*e-mail: gzywica@imp.gda.pl

studies of biomass-fired ORC system are described in publications [20, 21]. Article [22] presents various CHP technologies adapted to domestic environment, taking into account different possible thermal energy sources such as combustion engines, Stirling engines, gas micro-turbines, ORC and thermophotovoltaic systems. According to the authors of this article, small ORC systems achieve very high overall efficiency exceeding 90%. Examples of systems for combined heat and electricity generation, which are still at the research stage, were also presented in other articles, e. g. [23–25]. Article [23] shows in detail the research on the system with a vapour micro-turbine integrated with outer gear and electricity generator. The process of designing the CHP system with a spiral expander and electric capacity of 1 kW was discussed in publication [24]. The tests of ORC system having a heat output of 50 kW with screw expander were presented in article [25]. Literature concerning small ORC systems also pays much attention to modelling of such systems [26, 27] as well as economic analyses [28–31]. Some researchers try to anticipate the future evolution of small CHP systems, pointing to the potential benefits resulting from integration with energy storage facilities [32, 33] or from expansion of energy system enabling simultaneous heat and cold generation [34, 35].

The prototype of the CHP domestic energy system with ORC, developed at the Institute of Fluid-Flow Machinery, in Gdansk, will be presented in the further part of the article. The fuel for the energy system is biomass in the form of pellets. The electricity is produced using a high-speed oil-free vapour micro-turbine. The energy system dimensions allow for its installation in private houses. It is the first CHP energy system of that type in the country (and probably in this part of Europe). The prototype start-up took place in April 2014. Since then, different types of experimental studies have been carried out aiming at identification of characteristics of built device and its optimization. The main technical data of the developed energy system and the principal results of experimental studies are discussed in the following sections of the article.

## 2. Thermodynamic cycle and component selection

The prototype of the CHP domestic energy system with ORC was created within the framework of the research project co-financed by the European Union. The main objective of the project was to develop energy technologies enabling better use of renewable energy sources. Thus, the ORC system producing electricity was integrated with a biomass-fired boiler (fuel in the form of pellets). The fuel of that kind is an easily accessible source of renewable energy and its quantity only slightly depends on weather conditions. Besides, biomass is one of the most popular fuels used for heating of the family houses, especially in rural areas. Biogas was also considered as an alternative fuel. That is why the designed boiler [36] after the exchange of burner enables the use of gas fuel.

In the framework of prior design assumptions, the demand for heating and for electricity was estimated in an average sin-

gle-family house. On this basis, it was assumed that maximum generation capacities of the CHP system should be at level: approximately 25 kW of thermal power and approximately 2.5 kW of electric power. Under these assumptions, it was possible to use the expanders of different types. On account of the highest potential for further development, as well as operational aspects, it was decided to apply the oil-free vapour micro-turbine. Machines of this type, in the case of small ORC systems, have several advantages, the most important being [12–15, 37]: high efficiency, no wear parts, hermetic housing and low noise. Small dimensions enable to develop compact structure for the entire device which is essential for the use of ORC system in a domestic environment. The basic technical assumptions, which were laid out at the initial design stage, are presented in Table 1.

Table 1  
Basic parameters of the prototype CHP ORC energy system

<i>Parameter</i>	<i>Value</i>
Fuel	Biomass (pellets)
Heat output	~ 25 kW
Electrical power	~ 2.5 kW
Expander type	Vapour microturbine
Other requirements	Safe operation, small dimensions, quiet operation, reliability

After analyses and comparisons performed by a team of scientists from the IMP PAN, a mixture of substances under a trade name HFE-7100 was selected as the working medium [38]. This medium is a modern solvent; it is odourless and non-flammable. Its boiling point at atmospheric pressure is only 61°C. Thermodynamic cycle of the CHP energy system for the HFE-7100 was designed taking into account several criteria, such as: high efficiency of designed vapour micro-turbine, purchase price of other components, net maximum electrical capacity, and availability of control and measurement apparatus in the market. The simplified diagram of the energy system is presented in Fig. 1. A characteristic feature of the cycle was the use of regenerative heat exchanger, which guarantees fairly higher efficiency of the cycle for the selected working medium. Temperature-entropy graph (T-s) for the chosen thermodynamic cycle is showed in Fig. 2. Theoretical energy generation efficiency, according to this cycle, was around 13 % at theoretical net electrical capacity of 2.7 kW. These results conformed (with a certain “safety margin”) with the original design intent.

Based on the characteristics of energy system cycle, the selection criteria for all components were elaborated. Then the components were subject to theoretical analyses, design works and laboratory testing. The research was carried out in a laboratory specifically prepared for these tasks. The visual appearance of one of the test rigs was presented in Fig. 3. Finally, the best constructional solutions have been selected to guarantee

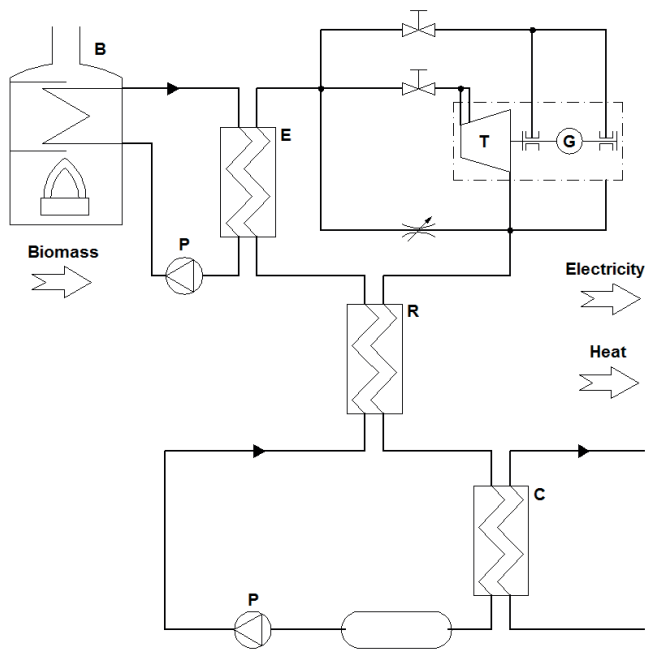

Fig. 1. Diagram of the energy system with a biomass-fired boiler (B – boiler, P – pump, T – turbine, G – generator, E – evaporator, R – regenerator, C – condenser)

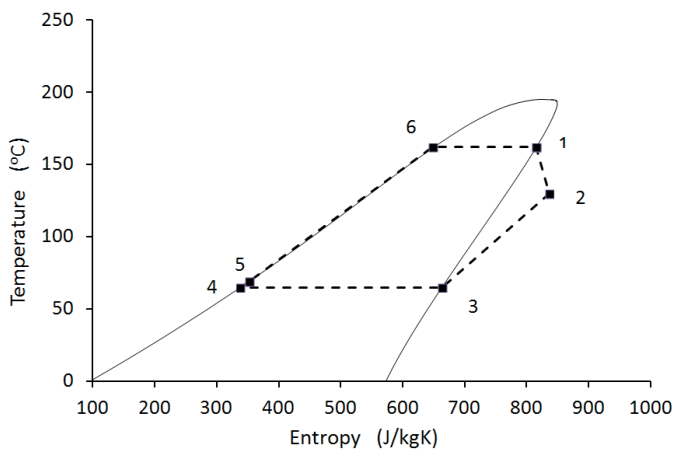

Fig. 2. Theoretical temperature-entropy graph for the energy system cycle with HFE-7100

Table 2

Basic parameters of the main components in the CHP ORC energy system

Component name	Basic properties
Boiler (biomass-fired)	Heat power (continuous) ~ 28 kW
Vapour turbine	Rated power – 2.7 kW (at 24 krpm)
Evaporator	Heat load – 25 kW
Regenerator	Heat load – 22.5 kW
Condenser	Heat load – 6.6 kW
Circulating pump	Nom. pressure difference – 10 bar Nominal capacity – 7.6 lpm



Fig. 3. Test rig for testing heat exchangers and expanders (including vapour micro-turbines) [12]

reliable operation and high efficiency of the entire machine. Specification of the basic parameters of the main components in the energy system is shown in Table 2.

Listed components have successfully undergone experimental tests with the working medium in conditions close to target conditions. It has resulted in several innovative, alternative solutions of boilers [36], circulating pumps [39], heat exchangers [40, 41] and micro-turbines [13, 42, 43] while working on the components at the IMP PAN. When selecting components, a high level of durability and reliability as well as relatively low price were important criteria, in addition to capacity demand and efficiency. The applied micro-turbine has gas bearings lubricated with vapour of low-boiling medium, which allowed the use of hermetic casing. High-speed generator with rare earth magnets was placed inside the casing, between the bearings. It is a four-stage radial turbine (two centripetal stages and two centrifugal stages). The applied micro-turbine should reach a flow efficiency up to 75% according to the design calculations. The visual appearance of the turbo-generator mounted on the frame of the micro power plant was presented in Fig. 4.

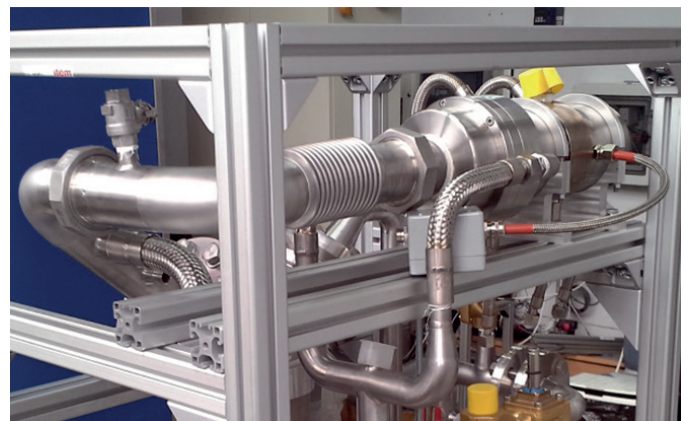

Fig. 4. Photo of turbo-generator mounted on the frame of the micro power plant

### 3. The design and construction of the prototype

The design solution of the energy system was developed in the form of 3-dimensional, parametric CAD model, on the basis of the design assumptions and selected components. Then, after preparation of the 2-dimensional technical documentation, the building of energy system at the laboratory of the IMP PAN commenced. The energy system installation together with the supporting structure and automatic control and energy condition system was named “CHP module”. This module, during normal operation, allows for generating electricity after being connected to any source of heat energy, in this case – the multi-fuel boiler with thermal oil circulation. The CHP module cooperating with a boiler form a complete CHP ORC energy system, which allows for converting the chemical energy of fuel into thermal energy and electric power.

The main principles which guided the process of design are listed below:

- logical grouping of prototype components around the largest component – regenerative heat exchanger,
- arrangement of energy system components towards each other so as to minimize length of the pipelines and to reduce the area occupied by them,
- realization of the following rule: hot vapour at the top, cold liquid at the bottom (micro-turbine – on the highest level, circulating pump – on the lowest level),
- the use of pipelines with diameters not smaller than nominal diameters of connecting components,
- the use of modular tank for the working medium, enabling the adjustment of the volume of the liquid in front of the pump,
- minimizing the number of angled connections and highly varying diameters of pipelines (trying to reduce pressure losses and drops),
- the use of flexible elements between joined components (compensation of thermal elongations, reducing the transmission of vibrations),
- replacing temporary fastenings by welded joints (improving the tightness of the installation) so long as to prevent dismantling of any component,
- the use of standard joints and materials that are commonly sold on the market (enabling easy rebuilding and repair),
- arrangement of components that support good air circulation, cooling the pump motors and automatics elements (air cooling from bottom to top),
- planning of so-called “transparency side”, on that side the control box and all screens were mounted, being part of adjustment and measuring equipment,
- the use of additional connections enabling easy serviceability of the system (e.g. filling, emptying, deaeration of the system).

When designing the energy system all commonly known principles of designing machinery were also used, maintaining relevant industry standards. The result of design works is presented in Fig. 5 in the form of a 3D model.



Fig. 5. Three-dimensional CAD model of the CHP ORC energy system

The control-measuring system was created in order to allow monitoring of the functioning of all components. The decision was taken to build an automatic control system, based on universal PLC controller which is combined with the system for the reception and conditioning of the electric energy. Control of all processes that occur in the energy system takes place from the level of computer screen. In addition, the energy system was fitted with a touch panel mounted on the control cabinet, displaying the most important operational parameters. The automatic control system allows for adjustment of operational parameters of the energy system components and also executive elements of the automatics, such as flow control valves. On the other hand, it also functions as a measurement and control system enabling achieving, visualization and archiving of measured signals. The photo of the energy system with measurement and control system is showed in Fig. 6.

### 4. The results of start-up tests

In the course of the research works under laboratory conditions, the energy system was equipped with electric energy receivers: electric heater with 5 kW of power capacity, 10 bulbs of 1kW total power capacity. The take-up of heat energy from the condenser took place through the system filled with an aqueous solution of glycol, fitted with outdoor dry air coolers. Combustion gases from the boiler were discharged through a stainless steel stack. During start-up tests, the boiler was fired with biomass in the form of pellets, which was delivered to the furnace using an automatic feeding screw.

The aim of start-up tests was primarily to verify the correct functioning of all main components cooperating with each



Fig. 6. The prototype of the CHP ORC energy system during the laboratory tests

other in the ORC cycle and also to check whether the protective equipment and automatic control system operate well [44]. The control valves had to be calibrated during these tests. The start-up tests began before completing thermal insulation of installation and some components (such as heat exchangers). It greatly facilitated searching for possible leakage points and allowed faster removal of leaks. It was connected with high heat losses that prevented the energy system from obtaining nominal operating parameters. Therefore, the effort was not aimed at achieving pre-determined micro-turbo-generator parameters during the first start-up attempts – those were carried out only to check whether the vapour micro-turbine functions properly. Preliminary tests lasted several hours in total. Selected measurement results are presented in the figures below.

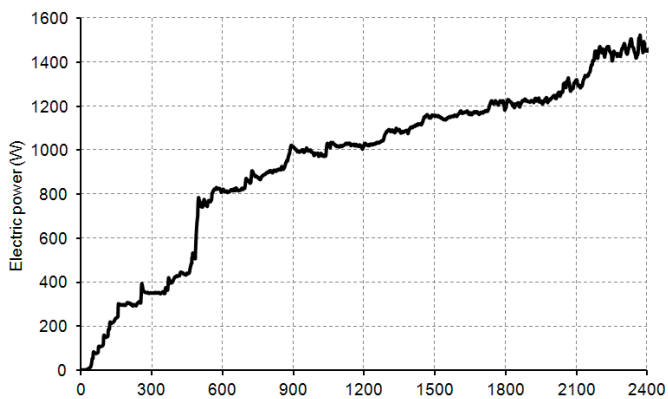

Fig. 7. Electric power produced by the turbo-generator during preliminary test

The amount of electricity generated during the 40 minutes start-up period is presented in Fig. 7. By adaptive control of the circuits, the stable operation and a gradual increase in power output were obtained. The maximum electrical power was above 1500 W at the output of electric energy conditioning system. The micro-turbine's shaft was operating with rotational speed around 18 000 rpm and around 6 000 rpm was still needed to reach nominal speed.

The temperature values of various media that are present in the installations of the energy system measured during 2400 seconds are shown in Figs. 8–10. For temperature measurements, thermocouples of accuracy class 1 were used. Figure 8 presents the graph of thermal oil temperature at boiler's outlet and at boiler's inlet. The maximum temperature at the evaporator inlet slightly exceeded 200°C only for a short time and at its outlet amounted to around 150°C. These parameters had stable values over the period considered. A decrease of oil temperature continued at the level of 50°C during the tests. The values of the temperature of low-boiling medium at different points of the ORC cycle are presented in Fig. 9. The temperatures

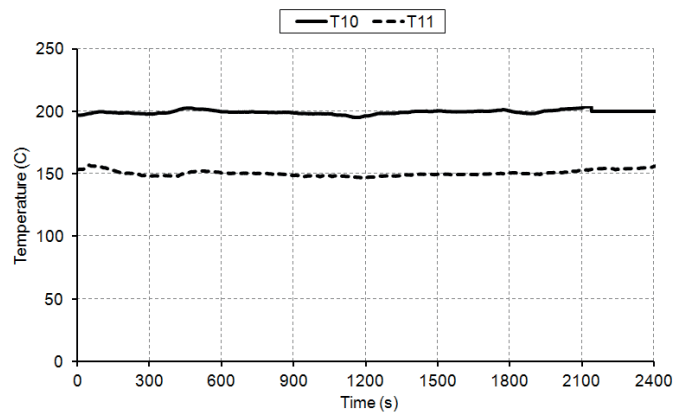

Fig. 8. The temperature of thermal oil during tests performed on the ORC energy system (T10 – temperature at the boiler outlet, T11 – temperature at the boiler inlet)

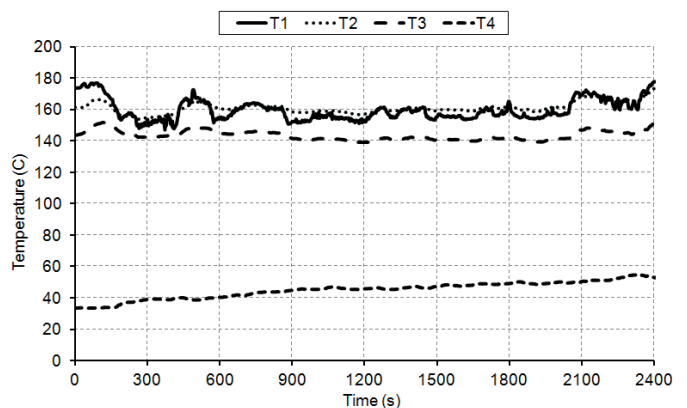

Fig. 9. The temperature of the working medium HFE-7100 during tests performed on the ORC energy system (T1 – temperature at the outlet of the evaporator, T2 – temperature at the inlet of the micro-turbine, T3 – temperature at the outlet of the micro-turbine, T4 – temperature in the tank at the inlet of the pump)

after the evaporator and before the micro-turbine remained at similar levels and this was an indication of low heat losses on that section. In the graphs presented below, a gradual increase in temperature of the low-boiling medium before the pump may also be observed. Its temperature was above 50°C towards the end of the period concerned. The difference in temperature between the inlet and outlet of the micro-turbine was in the range of 10 to 22°C. Figure 10 presents a graph showing the temperature of aqueous solution of glycol used to receive the heat in the condenser. The measurement was performed after the solution had flowed through the condenser, therefore, after receiving heat energy from the working medium. At the end of the measurements, the temperature of the solution of glycol reached up to 70°C and rose steadily, which was mainly the result of limited capabilities of heat consumption in the fan cooler. This problem increased at high air temperature outside the building.

Figure 11 shows a graph representing the pressure of the working medium at selected points in the ORC cycle. Pressure transducers had an increased accuracy of ±0.1%. The highest pressure value reaching 11 bar took place directly after the evaporator. The pressure before the micro-turbine (P2) continued to increase together with gradual opening of the control valve. It was only marginally lower than the pressure after the evaporator when the valve was fully open. The difference was approximately 0.3 bar. The vapour from the low-boiling medium, after being led through the micro-turbine, sharply declined its pressure to approximately 3 bar. The most significant pressure drop occurred at the end of measurement session – it was about 7.5 bar.

An important aspect to the tests performed on the ORC system is the flow rate of working medium. The measured value of flow rate for the low-boiling medium HFE-7100 was presented in Figure 12. The Coriolis flow meter with an accuracy of ±0.15% was used. In the figure one can observe gradual increase in flow rate of the working medium used in the energy system (up to a maximum of 140 g/s). It constitutes 83 % of the nominal value of flow rate, which is 169 g/s. In terms of flow parameters, their optimal values for the micro-turbine have not been achieved during the tests. Both the level of pressure dif-

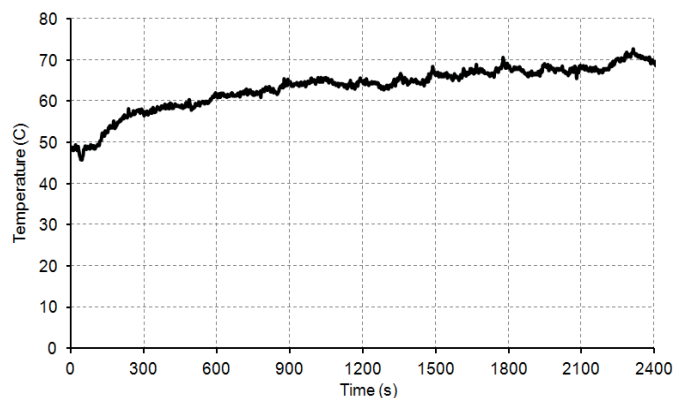

Fig. 10. Temperature of the aqueous solution of glycol at the outlet of the condenser during tests performed on the ORC energy system

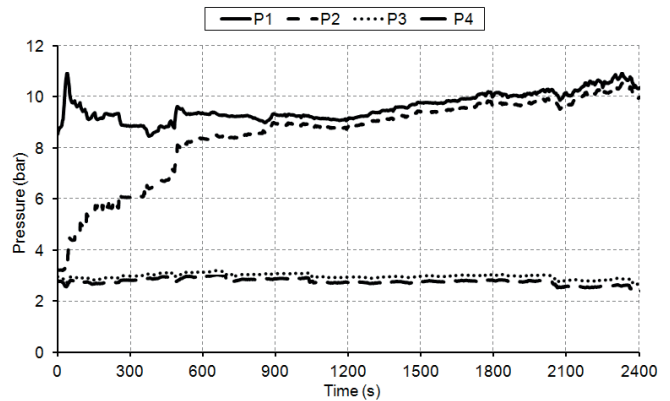

Fig. 11. The pressure of the working medium HFE-7100 during tests performed on the ORC energy system (P1 – pressure at the outlet of the evaporator, P2 – pressure at the inlet of the micro-turbine, P3 – pressure at the outlet of the micro-turbine, P4 – pressure in the tank at the inlet of the pump)

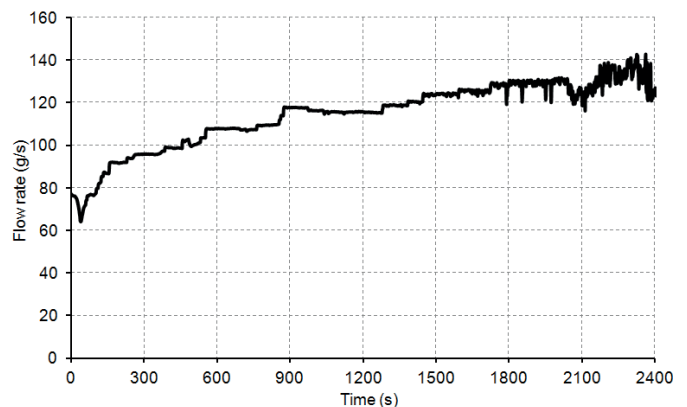

Fig. 12. The mass flow rate of the working medium HFE-7100 during tests performed on the ORC energy system

ference and flow rate were found to be below the design values. The flow rate of the thermal oil used as a heat-carrying agent between the boiler and the evaporator amounted to roughly 20 lpm. This value was close to the nominal value.

## 5. Summary and conclusions

The article presents the prototype of the CHP ORC energy system. The preliminary research results were obtained from the tests during which the proper operation of all components in working medium heating and cooling processes was tested, and also from the tests in the operating mode in which the micro-turbine generates electricity. The results confirmed the proper functioning of all components, automatic control system and the system receiving the electricity generated. The electrical power generated by the energy system was around 1.5 kW, because the installation was not yet fully prepared to achieve the nominal power. The turbine operates with lowered pressure and flow rate of the working medium, which impedes the performance of the system. The incomplete thermal insulation

resulted in relatively high heat losses. In view of the obtained results and the past experience of the research team, it can be said that when the installation is in optimal condition, the ORC energy system built will make it possible to generate around 2.5 kW of electric power.

The target group of the developed micro power plant are the inhabitants of single-family houses, who, up to now, have been using biomass or other fuels to heat buildings. To replace traditional central heating boilers with the CHP ORC energy system, the construction cost needs to be optimized and many hours of testing in real conditions should be performed. The works on the commercial version of the energy system are being planned for the future. They will be carried out in cooperation with a industrial partner having appropriate back-up facilities providing technology and marketing support as well as their own distribution network in the market. It seems that, with the right state policy related to the use of renewable energy, the domestic CHP ORC energy system proposed can become a very attractive and pollution-free energy source.

**Acknowledgments.** The research work presented in this article was supported by the scientific project POIG.01.01.02-00-016/08 “Model agroenergy complexes as an example of distributed cogeneration based on local renewable energy sources”.

## REFERENCES

- [1] J. Kicinski, “Do we have chance for small-scale energy generation? The examples of technologies and devices for distributed energy systems in micro & small scale in Poland”, *Bull. Pol. Ac.: Tech.* 61 (4), 749–756 (2013).
- [2] G. Qiu, H. Liu, and S. Riffat, “Expanders for micro-CHP systems with organic Rankine cycle”, *Applied Thermal Engineering* 31, 3301–3307 (2011).
- [3] W. Wang, Y. Wu, C. Maa, L. Liu, and J. Yu, “Preliminary experimental study of single screw expander prototype”, *Applied Thermal Engineering* 31, 3684–3688 (2011).
- [4] S. Declaye, S. Quoilin, L. Guillaume, and V. Lemort, “Experimental study on an open-drive scroll expander integrated into an ORC (Organic Rankine Cycle) system with R245fa as working fluid”, *Energy* 55, 173–183 (2013).
- [5] Ch. S. Wong, D. Meyer, and S. Krumdieck, “Selection and conversion of turbocharger as turbo-expander for organic Rankine cycle (ORC)”, *35th New Zealand Geothermal Workshop*, Rotorua (2013).
- [6] S.-W. Hsu, H.-W. D. Chiang, and Ch.-W. Yen, “Experimental Investigation of the Performance of a Hermetic Screw-Expander Organic Rankine Cycle”, *Energies* 7, 6172–6185 (2014).
- [7] S. Clemente, D. Micheli, M. Reini, and R. Taccani, “Energy efficiency analysis of Organic Rankine Cycles with scroll expanders for cogenerative applications”, *Applied Energy* 97, 792–801 (2012).
- [8] D. Fiaschi, G. Manfrida, and F. Maraschiello, “Thermo-fluid dynamics preliminary design of turbo-expanders for ORC cycles”, *Applied Energy* 97, 601–608 (2012).
- [9] P. Klonowicz, A. Borsukiewicz-Gozdur, P. Hanausek, W. Krylowicz, and D. Bruggemann, “Design and performance measurements of an organic vapour turbine”, *Applied Thermal Engineering* 63, 297–303 (2014).
- [10] S. Cordiner and V. Mulone, “Experimental-numerical analysis of a biomass fueled microgeneration power-plant based on microturbine”, *Applied Thermal Engineering* 71, 905–912 (2014).
- [11] D. Fiaschi, G. Manfrida, and F. Maraschiello, “Design and performance prediction of radial ORC turboexpanders”, *Applied Energy* 138, 517–532 (2015).
- [12] T. Kaczmarczyk, E. Ichnatowicz, S. Bykuc, G. Zywicka, and Z. Kozanecki, “Experimental investigation of the ORC system in a cogenerative domestic power plant with a microturbine and an expansion valve”, *ASME ORC 2013, 2nd International Seminar on ORC Power System*, Rotterdam (The Netherlands) (2013).
- [13] J. Kicinski and G. Zywicka, *Steam microturbines in distributed cogeneration*, Springer, 2014.
- [14] A. Borsukiewicz-Gozdur, “Experimental investigation of R227ea applied as working fluid in the ORC power plant with hermetic turbogenerator”, *Applied Thermal Engineering* 56, 126–133 (2013).
- [15] Z. Kozanecki, E. Tkacz, J. Lagodzinski and K. Miazga, “Theoretical and experimental investigation of oil-free bearings and their application in diagnostics of high-speed turbomachinery”, *Key Engineering Materials* 588, 302–309 (2014).
- [16] J. Kicinski and G. Zywicka, “The numerical analysis of the steam microturbine rotor supported on foil bearings”, *Advances in Vibration Engineering* 11(2), 113–120 (2012).
- [17] K. Kosowski, R. Stepień, W. Włodarski, M. Piwowarski and L. Hirt, “Partial admission stages of high efficiency for a micro-turbine”, *Proc. VETOMC III International Conference*, Gdansk, 115–125 (2012).
- [18] W. Nowak, A. Borsukiewicz-Gozdur, P. Klonowicz, A. Stachel, P. Hanausek and W. Klonowicz, “Small prototype of ORC power plant fuelled by water at 100°C: first experimental results”, *Przegląd Geologiczny* 58(7), 622–625 (2010).
- [19] L. Dong, H. Liu, and S. Riffat, “Development of small-scale and micro-scale biomass-fuelled CHP systems – A literature review”, *Applied Thermal Engineering* 29, 2119–2126 (2009).
- [20] G. Qiu, Y. Shao, J. Li, H. Liu, and S.B. Riffat, “Experimental investigation of a biomass-fired ORC-based micro-CHP for domestic applications”, *Fuel* 96, 374–382 (2012).
- [21] H. Liu, G. Qiu, Y. Shao, F. Daminabo and S.B. Riffat, “Preliminary experimental investigations of a biomass-fired micro-scale CHP with organic Rankine cycle”, *International Journal of Low-Carbon Technologies* 5, 81–87 (2010).
- [22] E. Saverio Barbieri, P.R. Spina, and M. Venturini, “Analysis of innovative micro-CHP systems to meet household energy demands”, *Applied Energy* 97, 723–733 (2012).
- [23] G. Pei, J. Li, Y. Li, D. Wang, and J. Ji, “Construction and dynamic test of a small-scale organic Rankine cycle”, *Energy* 36, 3215–3223 (2011).
- [24] D. Meyer, Ch. Wong, F. Engel, and S. Krumdieck1, “Design and build of a 1 kilowatt organic Rankine cycle power generator”, *35th New Zealand Geothermal Workshop*, Rotorua (2013).
- [25] V. Minea, “Power generation with ORC machines using low-grade waste heat or renewable energy”, *Applied Thermal Engineering* 69, 143–154 (2014).
- [26] H. Liu, Y. Shao, and J. Li, “A biomass-fired micro-scale CHP system with organic Rankine cycle (ORC) Thermodynamic modelling studies”, *Biomass and Bioenergy* 35, 3985–3994 (2011).
- [27] J.-B. Bouvenot, B. Latour, M. Siroux, B. Flament, P. Stabat, and D. Marchio, “Dynamic model based on experimental investigations of a wood pellet steam engine micro CHP for building energy simulation”, *Applied Thermal Engineering* 73, 1041–1054 (2014).

- [28] A. Schuster, S. Karellas, E. Kakaras, and H. Spliethoff, "Energetic and economic investigation of Organic Rankine Cycle applications", *Applied Thermal Engineering* 29, 1809–1817 (2009).
- [29] S.R. Wood and P.N. Rowley, "A techno-economic analysis of small-scale, biomass-fuelled combined heat and power for community housing", *Biomass and Bioenergy* 35, 3849–3858 (2011).
- [30] S. Quoilin, M. Van Den Broek, S. Declaye, P. Dewallef, and V. Lemort, "Techno-economic survey of Organic Rankine Cycle (ORC) systems", *Renewable and Sustainable Energy Reviews* 22, 168–186 (2013).
- [31] A. Algieri and P. Morrone, "Techno-economic analysis of biomass-fired ORC systems for single-family combined heat and power (CHP) applications", *Energy Procedia* 45, 1285–1294 (2014).
- [32] X.P. Chen, Y.D. Wang, H.D. Yu, D.W. Wu, Yapeng Li, and A.P. Roskilly, "A domestic CHP system with hybrid electrical energy storage", *Energy and Buildings* 55, 361–368 (2012).
- [33] K. Bogucka-Bykuc, W. Wlosinski, and S. Bykuc, "Towards development of a prototype high-temperature latent heat storage unit as an element of a RES-based energy system (part 1)", *Bull. Pol. Ac.: Tech.* 62 (3), 489–494 (2014).
- [34] D. Maraver, A. Sin, J. Royo, and F. Sebastian, "Assessment of CCHP systems based on biomass combustion for small-scale applications through a review of the technology and analysis of energy efficiency parameters", *Applied Energy* 102, 1303–1313 (2013).
- [35] K. Smierciew, J. Gagan, D. Butrymowicz, and J. Karwacki, "Experimental investigations of solar driven ejector air-conditioning system", *Energy and Buildings* 09, 260–267 (2014).
- [36] D. Kardas, T. Turzynski, I. Wardach-Swiecicka, and K. Rone-wicz, *Combustion and heat transfer in oil biomass boiler*, IFFM Publisher, Gdansk, 2014.
- [37] G. Zywica, M. Drewczynski, J. Kicinski, and R. Rzadkowski, "Computational Modal and Strength Analysis of the Steam Microturbine with Fluid-Film Bearings", *Journal of Vibration Engineering & Technologies* 2(6), 543–549 (2014).
- [38] J. Mikielewicz, D. Mikielewicz, E. Ihnatowicz, T. Kaczmarczyk, J. Wajs, R. Matysko, S. Bykuc, and W. Rybinski, *Thermodynamic cycles of the domestic micro CHP ORC power plant*, IFFM Publisher, Gdansk, 2013.
- [39] M. Kaniecki, Henke A., and Krzemianowski Z., *Pump units for the micro CHP ORC system with low boiling agent*, IFFM Publisher, Gdansk, 2013.
- [40] D. Mikielewicz, J. Mikielewicz, E. Ihnatowicz, T. Muszynski, J. Wajs, W. Rybinski, *Selected aspects of the design and testing of heat exchangers for domestic micro CHP ORC cycle*, IFFM Publisher, Gdansk, 2013.
- [41] M. Lackowski, A. Krupa, D. Butrymowicz, "Dielectrophoresis flow control in microchannels", *Journal of Electrostatics*, 71, 921–925 (2013).
- [42] Z. Kozanecki, D. Kozanecka, P. Klonowicz, J. Lagodzinski, M. Gizelska, E. Tkacz, K. Miazga, and A. Kaczmarek, *Oil-free micro-power turbomachinery*, IFFM Publisher, Gdansk, 2014.
- [43] R. Stepien, *Selected aspects of the design of multistage axial microturbines*, IFFM Publisher, Gdansk, 2013.
- [44] J. Kicinski, G. Zywica, Z. Kozanecki, E. Ihnatowicz, T. Kaczmarczyk, T. Turzynski, S. Bykuc, J. Niewiadomski, and D. Kardas, "Preliminary studies of the micro CHP ORC prototype. Determination of the initial characteristics", *Internal Report of IFFM PAS no 196/2014*, Gdansk 2014, (in Polish).