

Vector operation of one-cycle controlled matrix rectifier

XINGHUA YANG, JIANGUO JIANG, XIJUN YANG

No.800, DongChuan Road, MinHang District, Shanghai, P. R. China, 200240
Shanghai Jiao Tong University

e-mail: yangxinghua2004@126.com

(Received: 21.07.2011, revised: 13.12.2011)

Abstract: A novel vector operated one-cycle control matrix rectifier (OCC-MR) is proposed in this paper. Matrix rectifier (MR) is a generalized buck three-phase AC-DC converter with four-quadrant operation capability. MR can also be the front-stage circuit of AC-DC-AC equivalent structure of MC. One-cycle control (OCC) is a nonlinear control technique, which integrates modulation algorithm and control strategy. By applying OCC to current control loop, the OCC-MR achieves balance only in a switching cycle, and realizes unitary input power factor. Furthermore, vector operation of OCC results in minimum switching losses. In order to make up for the insufficiency of OCC on load disturbance suppression, a PID controller is added onto output voltage control to improve load regulation. The OCC-MR features great simplicity, fast dynamic response and good immunity on input disturbance. On the basis of theoretical analysis, a systematic simulation of OCC-MR is implemented by means of Matlab/Simulink. Both static state performance and dynamic state performance of OCC-MR are discussed deeply. The simulation results have proved theoretical analysis of the vector operation of OCC-MR, and the control effects are satisfactory.

Key words: matrix rectifier, one-cycle control, unitary power factor, vector operation

1. Introduction

Three-phase to three-phase matrix converter (MC) can be derived into three-phase to two-phase MC by removing any group of three bidirectional switches, which is responsible for yielding one phase output [1, 2]. When the desired output frequency is set to zero, the three-phase to two-phase MC is a three-phase AC-DC MC, i.e. DC matrix converter, named matrix rectifier (MR) for convenience here. It is a generalized buck three-phase AC-DC converter with four-quadrant operation capability [2]. Matrix rectifier provides bipolar output voltage, sinusoidal input current with minimum higher order harmonics, its input current waveform is pure sinusoidal, and the input power factor is near unity. Simultaneously it has bi-directional energy flow capability. In addition, MR can also be the front-stage circuit of AC-DC-AC

equivalent structure of MC and that of quasi-sparse matrix converter [3, 4]. At this point, a further study on MR is significant.

Up to now, there are mainly three methods to control MR, they are, switch function method [5, 6], scalar method [7-9] and space vector pulse-width-modulation (SVPWM) method [10-12]. Other methods can be mainly derived from the three ones [13-18].

The first method contributed by Venturini needs calculating the switch timings directly according to the relationship between the input voltages and the target output voltages [5]. This method is of little practical significance because of cumbersome calculation for a practical implementation and the 50% voltage ratio limitation. Venturini's optimum method employs the common-mode addition technique to achieve a maximum voltage ratio of 86.67%. The formal statement of the algorithm, including displacement factor control, is rather complex and appears unsuitable for real time implementation.

The scalar modulation method is typical among a number of modulation methods which have been developed, where the switch action signals are calculated directly from measurements of the input voltages. The motivation behind their development is usually given as the perceived complexity of the Venturini method. The scalar method relies on the measurement of the instantaneous input voltages.

The SVPWM is well known and established in conventional PWM inverters. Its application to MR is conceptually the same, but is more complex. For a MR, the SVPWM can be applied to input current control.

All of the methods mentioned above need many sensors for the voltages and multipliers for the three-phase current references, which results in a complex circuit, high cost, and low stability.

A new nonlinear control technique, one-cycle control (OCC), was introduced in [19] for constant switching frequency operation. This technique can establish a large-signal nonlinear PWM scheme that features a simple circuit, high performance, and universal applications. The OCC technique takes advantage of the pulsed and nonlinear nature of switching converters and achieves instantaneous dynamic control of the average value of a switched variable, e.g., voltage or current; more specifically, it takes only one switching cycle for the average value of the switched variable to reach a new steady-state after a transient. There is neither steady-state error nor dynamic error between the control reference and the average value of the switched variable. This technique provides fast dynamic response, excellent power source perturbation rejection, robust performance, and automatic switching error correction [20]. This technique can be extended to control variable frequency switches. The one-cycle control technique is general, and it is suitable for the control of PWM converters and resonant-based converters for either voltage or current control. OCC has been successfully implemented in many aspects of power electronics including dc/dc converters [19], ac/dc converters [21], dc/ac inverters [22], PFC's [23-26], and both single-phase and three-phase active power filter (APF) [27].

In this paper, a new three-phase vector-operated OCC-MR is proposed. It achieves three-phase unity PF and low THD without complex reference calculation. The OCC control circuit includes two integrators with reset as well as a few linear and digital components. The OCC-MR features constant switching frequency (beneficial for magnetic design) and vector

operation (lower switching losses compared to the traditional PWM operation). In order for a new concept to be industrially and commercially adoptable, a rigid evaluation for all possible practical scenarios is performed and solid engineering design guidelines are developed. The structure of this paper is arranged as follows: the principle of OCC is reviewed in Section 1; the vector operation of OCC MR is analyzed in Section 2; Section 3 presents the simulations results, including both steady state and dynamic state; and conclusions are given in Section 5.

2. Principle of OCC

The essence of one-cycle control lies in the control of duty ratio of the switch so as to making the average value of the switched variable equal to the control reference during one switching cycle [12].

A switch operates according to the switch function $k(t)$ at a frequency $f_s = 1/T_s$,

$$k(t) = \begin{cases} 1 & 0 < t < T_{ON} \\ 0 & T_{ON} < t < T_s \end{cases} \quad (1)$$

In each cycle, the switch is on state for a time duration T_{ON} and is off state for a time duration T_{OFF} , where $T_{ON} + T_{OFF} = T_s$. The duty ratio $d = T_{ON}/T$ is modulated by an analog control reference $v_{ref}(t)$. The input signal $x(t)$ at the input node of the switch is chopped by the switch and transferred to the output node of the switch to form a switched variable $y(t)$. The frequency and the pulse width of the switched variable $y(t)$ is the same as that of the switch function $k(t)$, while the envelope of the switched variable $y(t)$ is the same as the input signal $x(t)$ as shown in Fig. 1.

$$y(t) = k(t)x(t). \quad (2)$$

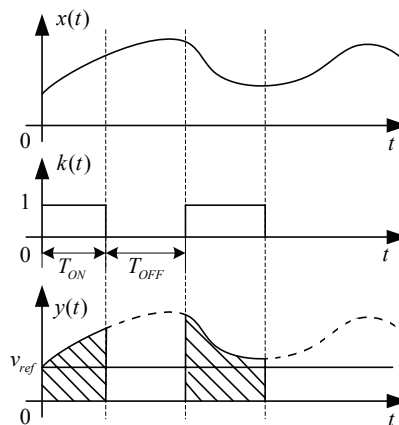

Fig. 1. Principle of one-cycle control

Suppose the switch frequency f_s is much higher than the frequency band width of either the input signal $x(t)$ or the control reference $v_{ref}(t)$; then the effective signal carried in the switch output, i.e. the average of the switched variable is

$$y(t) = \frac{1}{T_S} \int_0^{T_{ON}} x(t) dt \approx x(t) \frac{1}{T_S} \int_0^{T_{ON}} dt = x(t) \cdot d(t). \quad (3)$$

The switched variable $y(t)$ at the output node of the switch is the product of the input signal $x(t)$ and the duty ratio $d(t)$; therefore, the switch is characteristic of nonlinearity.

If the duty ratio of the switch is modulated such that the integration of the switched variable at the switch output is exactly equal to the integration of the control reference in each switching cycle, i.e.

$$\int_0^{T_{ON}} x(t) dt = \int_0^{T_S} v_{ref}(t) dt. \quad (4)$$

then the average value of the switched variable at the switch output is exactly equal to the control reference in each cycle, since the switching period is constant.

$$\frac{1}{T_S} \int_0^{T_{ON}} x(t) dt = \frac{1}{T_S} \int_0^{T_S} v_{ref}(t) dt. \quad (5)$$

Therefore, the average of the switched variable is instantaneously controlled within one cycle, i.e.

$$y(t) = \frac{1}{T_S} \int_0^{T_{ON}} x(t) dt = \frac{1}{T_S} \int_0^{T_S} v_{ref}(t) dt = v_{ref}(t). \quad (6)$$

The technique to control switches according to this concept is defined as the one-cycle control technique. With one-cycle control, the effective output signal of the switch is

$$y(t) = v_{ref}(t). \quad (7)$$

The switch rejects the input signal fully and all-passes the control reference v_{ref} linearly; therefore, the one-cycle control technique is capable of turning a non-linear switch into a linear path. The implementation circuit for One-Cycle Controlled constant-frequency switch is shown in Fig. 2.

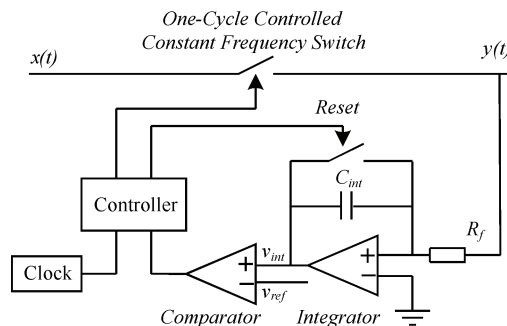

Fig. 2. One-cycle controlled constant frequency switch [19]

The key component of the one-cycle control technique is the integrator and the reseter. The integration starts the moment when the switch is turned on by the fixed frequency clock pulse. The integration value,

$$v_{int} = k \int_0^t x(t) dt \tag{8}$$

is compared with the control reference $v_{ref}(t)$ instantaneously, where k is a constant. At the instant when the integration value v_{int} reaches the control reference $v_{ref}(t)$, the controller sends a command to the switch to change it from the on state to the off state. At the same time, the controller resets the integrator to zero. The duty-ratio $d = T_{ON}/T_s$ of the present cycle is determined by the following equation,

$$k \int_0^t x(t) dt = v_{ref}(t). \tag{9}$$

Since the switch period T_s is constant, and $K = 1/kT_s$ is a constant, the average value of the switched variable at the switch output $y(t)$ is guaranteed to be

$$y(t) = \frac{1}{T_s} \int_0^{dT_s} x(t) dt = K v_{ref}(t) \tag{10}$$

in each cycle. Figure 3 shows the operating waveforms of the circuit, when $v_{ref} = \text{constant}$.

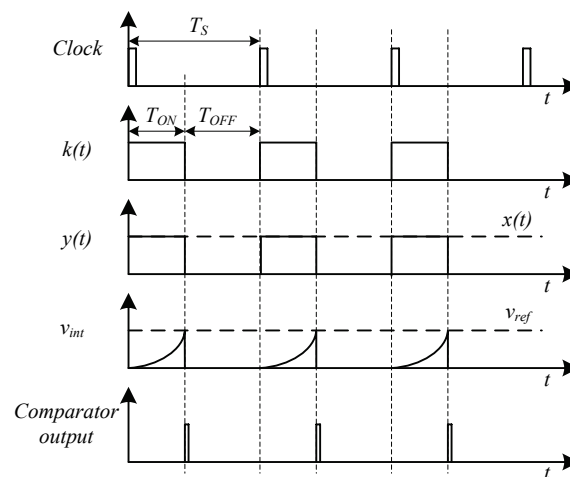

Fig. 3. Waveforms of the one-cycle controlled constant frequency switch

Note that any physical or signal switch can be one-cycle controlled, i.e. the switched variable can be any switched physical variable or abstract signal.

3. Vector Operation of OCC-MR

A) Topology of OCC-MR

The OCC-MR shown in this paper is composed of a three-phase bridge as the main circuit, commutation and drive circuit and a one-cycle controller as shown in Fig. 4(a). The main circuit is a three-phase bridge current source rectifier. The dc-bus current is developed by an inductor. The power line provides symmetric sinusoidal three-phase voltages and currents in normal operation. The bridge rectifier contains a three-phase LC filter and six bidirectional switches that are of common-emitter anti-parallel type. The converter operates in continuous conduction mode (CCM) under the condition of high switching frequency and proper design of the inductor.

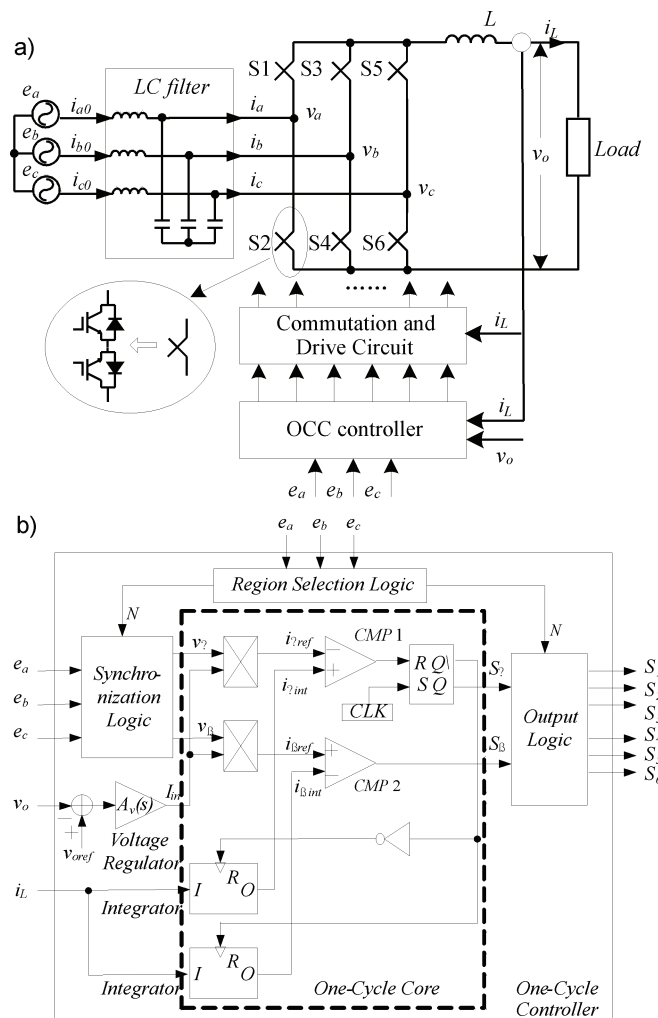

Fig. 4. Circuits of the OCC-MR: (a) Main circuit of the OCC-MR, (b) OCC controller

Although adding LC filter to a power converter is generally associated with losses and hence can be said to reduce the overall efficiency, the input LC filter attenuates the high-frequency normal-mode current and shunts the common-mode currents at the input side. So input current harmonics and conducted EMI of OCC-MR is reduced effectively. For there are many technical publications that research the design method and influence of LC filter in a power converter [28-29], it is not discussed detailedly in this paper any more.

The control circuit contains an OCC core, some vector operation logic, and a voltage feedback circuit, as shown in Fig. 4(b). The OCC core includes two multipliers, two comparators, and two integrators with reset as well as one flip-flop; the vector operation logic contains a vector region selection circuit that divides a line cycle into six regions according to the power line voltage (shown in Fig. 5), a synchronizing circuit that selects the vector voltages v_α and v_β from the three phase voltages e_a , e_b and e_c as the synchronizing signals of input phase currents (shown in Table 1), and the voltage feedback loop that regulates the dc-bus voltage and generates the amplitude signal of input currents. The dc-bus voltage is regulated against a reference voltage so that it keeps constant during steady-state operation. The error signal passes a proportion-integration (PI) regulator to form the modulation signal. The OCC control core takes the modulation signal together with the vector voltages to generate current references i_α and i_β . The output current i_L passes to two integrators, of which the results are compared with current references to produce switch trigger signals S_α and S_β . The output logic circuit takes the switch trigger signals S_α and S_β together with the result of region selection circuit to produce the duty ratios of the six bidirectional switches.

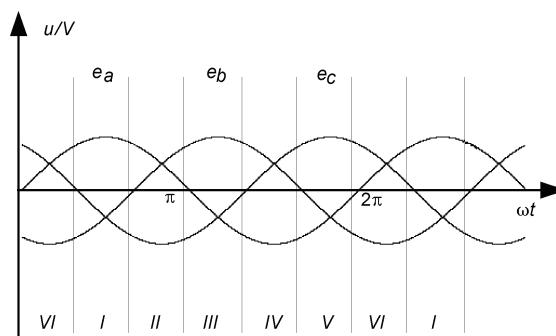

Fig. 5. Regions of input phase voltage

B) Vector operation of OCC-MR

For vector operation, a line cycle, as shown in Fig. 5, is evenly divided into six regions according to the zero-crossing points of each phase voltage. In each region, the two switches of the dominant phase, whose voltage polarity is opposite to the other two, are kept ON and OFF, respectively, in the entire region, which brings about minimum switching losses. The switches of the other phases are controlled at switching frequency. The vector enters a new region in each 60° of one line cycle. This mechanism is shown in Table 1.

In this fashion, the six-switch bridge can be decoupled into a parallel-connected dual-buck topology. For example, in region I ($60^\circ \div 120^\circ$), supposing output voltage is positive, switch S_1 is kept ON and switches S_3 and S_5 are kept OFF for the entire region, while switches S_2 , S_4 and S_6 are controlled at switching frequency as shown in Fig. 6. The circuit can be treated as a parallel-connected dual-buck converter with the input voltage of v_{ac} and v_{ab} as shown in Fig. 7.

Table 1. Vector operation mechanism of the OCC-MR when output voltage is positive

Region	VI	I	II	III	VI	V	
Angle of phase voltage (v_a)	$0^\circ \div 60^\circ$	$60^\circ \div 120^\circ$	$120^\circ \div 180^\circ$	$180^\circ \div 240^\circ$	$240^\circ \div 300^\circ$	$300^\circ \div 360^\circ$	
Synchronizing signal	v_a	e_a	e_b	e_b	e_c	ec	e_a
	v_β	e_c	e_c	e_a	e_a	e_b	e_b
Controlled currents	i_a	i_a	i_b	i_b	i_c	i_c	i_a
	i_β	i_c	i_c	i_a	i_a	i_b	i_b
Output logic	on	S_4	S_1	S_6	S_3	S_2	S_5
	off	$S_2 S_6$	$S_3 S_5$	$S_2 S_4$	$S_1 S_5$	$S_4 S_6$	$S_1 S_3$
	S_α	S_1	S_4	S_3	S_6	S_5	S_2
	S_β	S_5	S_6	S_1	S_2	S_3	S_4

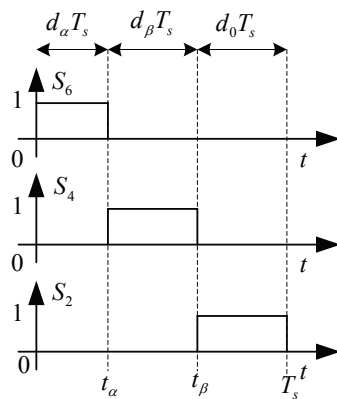

Fig. 6. Drive pulses of S_2 , S_4 and S_6

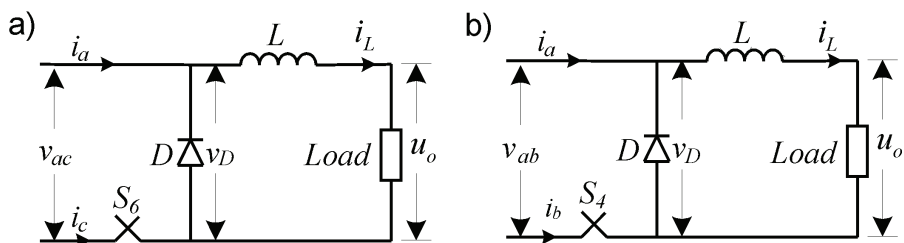

Fig. 7. Equivalent circuit of OCC-MR in Sector I, (a) S_6 on, S_2 , S_4 off, (b) S_4 on, S_2 and S_6 off

When switch S_6 is ON, S_2 and S_4 are OFF, $t \in [0, t_\alpha]$, the resulting equivalent circuit of OCC-MR is as shown in Fig. 7a.

$$\begin{cases} i_a = -i_c = i_L \\ i_b = 0 \end{cases} \quad (11)$$

When switch S_4 is ON, S_2 and S_6 are OFF, $t \in [t_\alpha, t_\beta]$, the yielding equivalent circuit of OCC-MR is shown in Fig. 7b).

$$\begin{cases} i_a = -i_b = i_L \\ i_c = 0 \end{cases} \quad (12)$$

When switch S_2 is ON, S_4 and S_6 are OFF, $t \in [t_\beta, T_s]$, phase currents i_b and i_c are equal to zero, i.e.

$$\begin{cases} i_b = -i_c = 0 \\ i_a = i_L \end{cases} \quad (13)$$

The average values of phase currents i_b and i_c during one switch cycle are given by

$$\tilde{i}_b = \frac{1}{T_s} \int_{t_\alpha}^{T_s} i_b dt = -\frac{1}{T_s} \int_{t_\alpha}^{\beta} i_L dt \quad (14)$$

$$\tilde{i}_c = \frac{1}{T_s} \int_0^{t_\alpha} i_c dt = -\frac{1}{T_s} \int_{t_\alpha}^{t_\beta} i_c dt = \frac{1}{T_s} \int_0^{t_\alpha} i_L dt. \quad (15)$$

For the switched variables i_b and i_c are controlled to reach the references i_{bref} and i_{cref} , respectively, in one switching cycle, if we define references i_{bref} and i_{cref} as

$$i_{bref} = I_{in} \sin(\omega t + \varphi_b) \quad (16)$$

and

$$i_{cref} = I_{in} \sin(\omega t + \varphi_c), \quad (17)$$

where I_{in} is the amplitude of phase currents, which is the output of voltage regulator, φ_b and φ_c are initial phases of voltage e_b and e_c , then the duty ratios of switch S_6 and S_4 can be derived from equations (18) and (19).

$$i_b = \frac{1}{T_s} \int_{t_\alpha}^{t_\beta} i_L dt = i_{bref} = I_{in} \sin(\omega t + \varphi_b) \quad (18)$$

and

$$i_c = \frac{1}{T_s} \int_0^{t_\alpha} i_L dt = i_{cref} = I_{in} \sin(\omega t + \varphi_c). \quad (19)$$

If the currents i_b and i_c are controlled to track phase voltages e_b and e_c , respectively, the third current i_a tracks phase voltage e_a automatically, since $i_a + i_b + i_c = 0$ and $e_a + e_b + e_c = 0$ are always satisfied in an individual MR in normal operation. Therefore, the power factor of MR is unity. Moreover, only two phase currents with smaller absolute value are switched at high frequency, while the phase current with the maximum absolute value is fixed ON or OFF in each region. Thus, the switching losses are greatly reduced.

If the output voltage is negative, switch S_2 is kept ON and switches S_4 and S_6 are kept OFF for the entire region, while switches S_1 , S_3 and S_5 are controlled at switching frequency. The duty ratios of S_5 and S_3 can be calculated according to (18) and (19).

Similarly, the equivalent circuit and the control key equations of other regions can be derived in the same manner. All the control key equations can be implemented by the same OCC control circuit that rotates from region to region dictated by a voltage selection circuit and a drive signal distributor according to the region selection signal.

C) Design of voltage regulator

With one cycle control, transfer function from current reference to input phase current is simplified to a first order system. For the input current tracks the phase voltage, the OCC-MR is equivalent to a three-phase resistance load. According to active power conservation law,

$$\frac{1}{2}(I_a^2 R_a + I_b^2 R_b + I_c^2 R_c) = \frac{3}{2} I_{in}^2 R_{in} = I_L^2 R_0 \quad (20)$$

i.e.

$$I_L = \sqrt{(3R_{in})/(2R_0)} * I_{in}, \quad (21)$$

where, $I_a = I_b = I_c = I_{in}$ are the amplitudes of input phase currents, $R_{in} = R_u = R_v = R_w$ are input impedances of OCC-MR, R_0 is the load. The output voltage of OCC-MR is

$$u_o = I_L * R_0 = \sqrt{3R_{in} R_0} * I_{in} = R_{eq} I_{in}. \quad (22)$$

In order to eliminate the influence of load disturbance on the system, a PI controller is applied to the outer voltage control loop. The control structure of voltage regulator is shown in Fig. 8. It is very easy to set up the parameters of PI controller by means of poles placement.

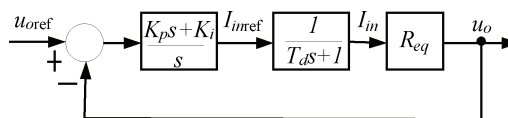

Fig. 8. Control structure of output voltage

D) Stability consideration

With the proposed approach, the output current may experience a large distortion at startup. Since all the switches are off at the moment of startup, the output current of OCC-MR

is zero. So the results of integrators in one-cycle controller are zero. According to formulas (18) and (19), the duty ratios of switches are fixed to 1, and the input voltage is delivered to output side directly. The output current will increase fast. Then the results of integrators become very large, so duty ratios are fixed to 0 next cycle and all switches are turned off. So the One-Cycle Controller does not work properly at the beginning. To solve this problem, a soft startup process is used in this paper. When the power is turn on, controller starts to work. The duty ratio of switches is limited to a small value. As the output current increases, the duty ratio increases. With the soft startup process, current distortion is eliminated.

During the operation, when the load or output voltage reference is changed suddenly, the output of voltage regulator may vary sharply. Since the OCC-MR is a kind of current source rectifier, the output current would not be changed suddenly. If the amplitude of input current reference is larger than that of output current, in certain regions of the line cycle, the duty ratios calculated according to formulas (18) and (19) will fixed to 1 or 0, and the converter is not chopped anymore. The converter could be “partly uncontrolled.” The “partly uncontrolled” phenomena could deteriorate the performance of OCC-MR.

In order to control the converter fully, the output of voltage regulator, i.e. I_m should be limited.

$$I_m \leq \frac{2u_0 I_L}{3E}, \quad (23)$$

where E is the amplitude of input phase voltages. For the output voltage and current vary with the load, the limitation to voltage regulator is changed.

It is worthy to note that, since the output of voltage regulator can't be changed in a sudden and its slope is limited, the response of voltage loop is also limited.

4. Simulation analysis

To verify the proposed control scheme, the OCC-MR is simulated using Power System Blockset in MATLAB/SIMULINK environment. The parameters of the system are given in Table 2. The whole system is simulated in the discrete time domain with the sampling frequency of 10 kHz.

To check the performance of OCC-MR, steady state and some typical dynamic states of the circuit in practical operation are investigated, which include the following:

- 1) Normal operation, e.g., balanced input voltages, constant load and control reference;
- 2) Changes of control command, e.g., output voltage reference varies in a step;
- 3) Fast load change, e.g., load power varies in a step;
- 4) Unbalanced input voltage source, e.g., the amplitude of one phase voltage is reduced by 20%.

The simulation results are shown in Figs. 9-12, respectively.

Figure 9 shows the normal operation of OCC-MR. The input voltage sources are balanced. The load and output voltage control reference are fixed to 25 Ω and 200 V, respectively. The input currents are balanced and input power factor is unity. The THD of input current is 3.90%. The ripple of output voltage is less than 5.0 V.

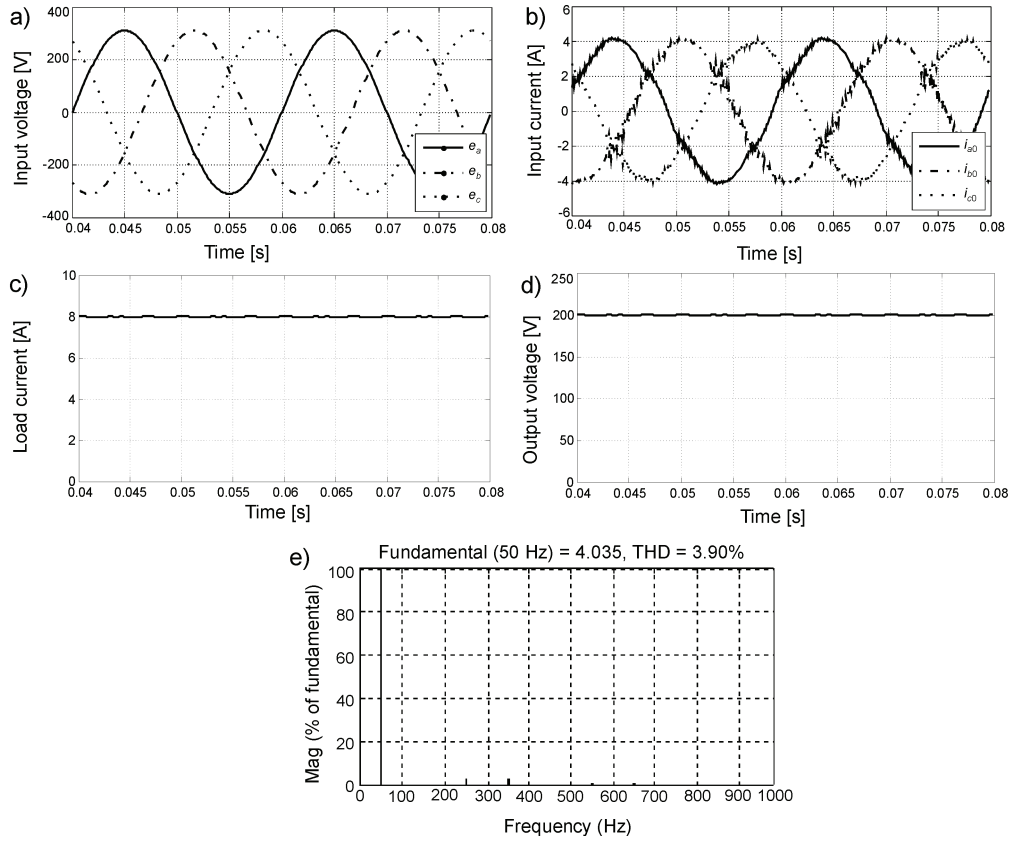

Fig. 9. Normal operation of OCC-MR: (a) input voltage; (b) input current; (c) output current; (d) output voltage; (e) THD of input current i_{a0}

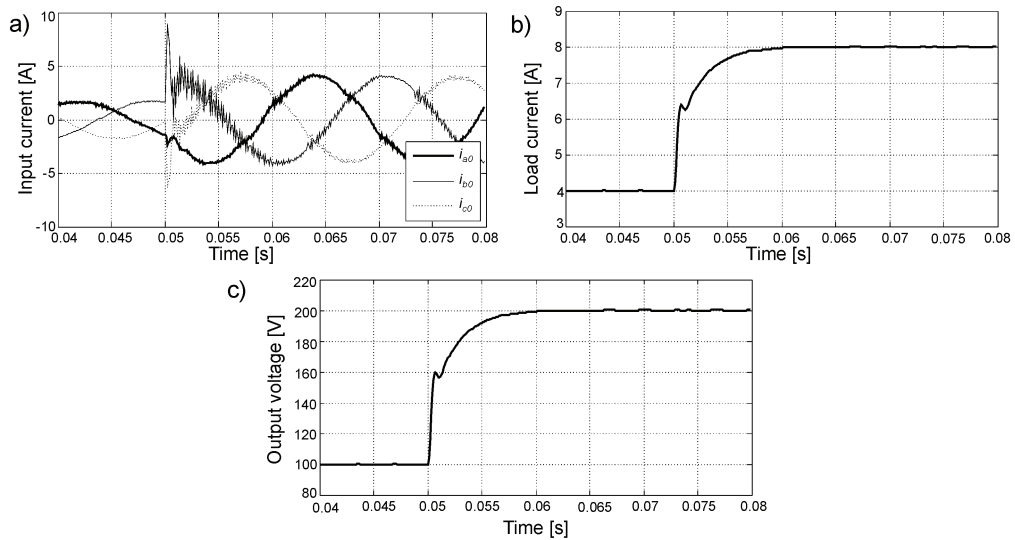

Fig. 10. Control reference following of OCC-MR: (a) input current; (c) output current; (d) output voltage

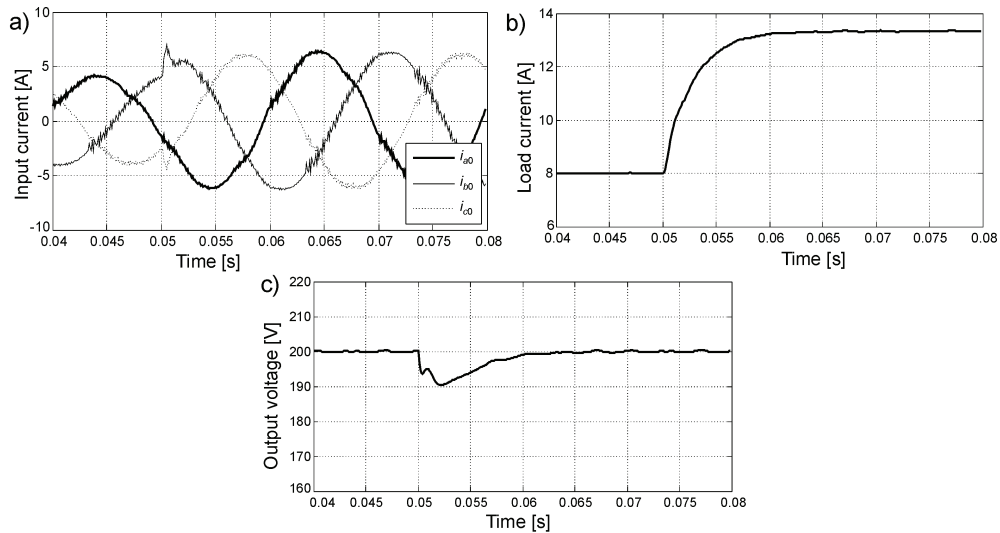

Fig. 11. Load disturbance rejection of OCC-MR: (a) input current; (b) output current; (c) output voltage

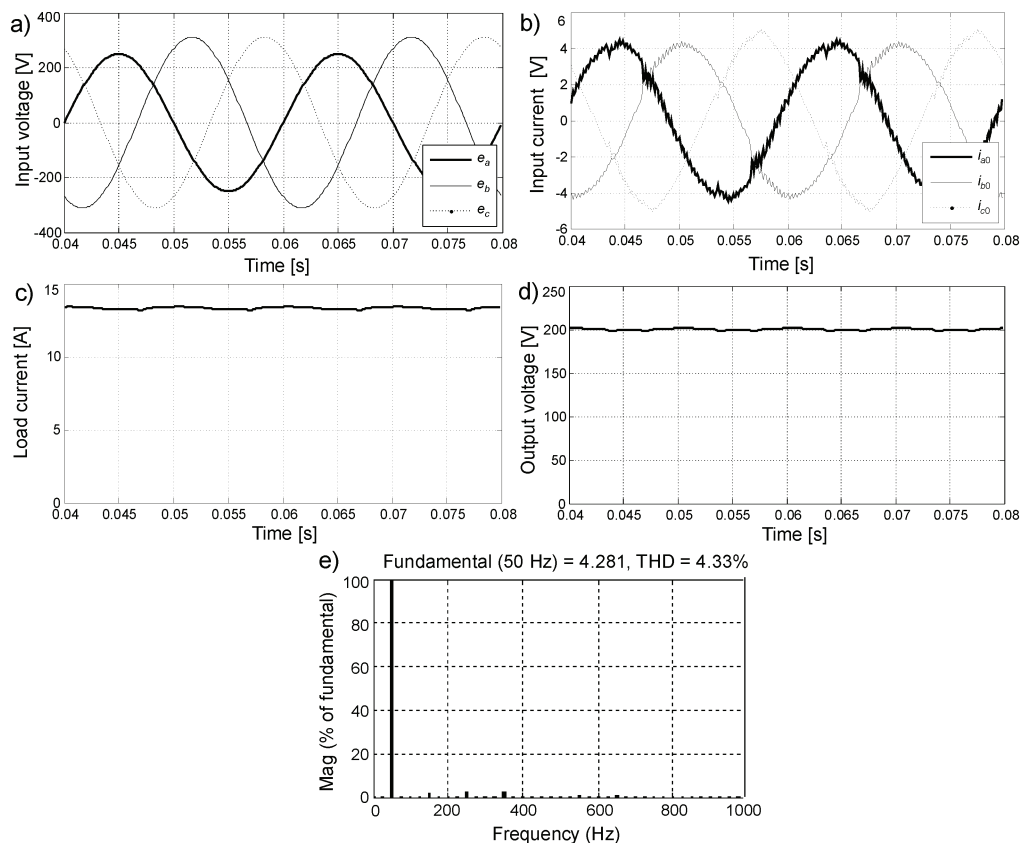

Fig. 12. Vector operation of OCC-MR under unbalanced input voltage source: (a) unbalanced input voltage; (b) input current; (c) output current; (d) output voltage; (e) THD of input current i_{a0} .

Table 2. The parameters of the OCC-MR system

Three phase source	220 VAC
LC filter	$L = 0.5 \text{ mH}$, $C = 5 \text{ uF}$
DC-link inductor	5.5 mH
DC-link voltage	200 V
Sampling frequency	10 kHz
Switching frequency	10 kHz
Resistive load	25 Ω
Voltage regulator	$K_p = 0.1$, $K_i = 30$

Figure 10 gives the dynamic response of OCC-MR. Suppose the load is constant and input voltages are balanced without any perturbation. The voltage control reference is sharply changed from 100 V to 200 V at $t = 0.05\text{s}$. The error between reference and the real value of output voltage causes the change of amplitude of input current reference. With one cycle control, input currents can track their references in each cycle. Therefore, the tracking performance of voltage control reference largely depends on the performance of the voltage regulator. From the simulation results, it can be concluded that the output of OCC-MR reaches new stable state within 0.01 s.

To study the load disturbance rejection of OCC-MR, the load is changed from 25 Ω to 15 Ω at $t = 0.05 \text{ s}$, at the same time the voltage control reference is kept constant and input voltages are balanced without any perturbation. Intrinsically, Since the OCC-MR is a kind of current source rectifier, the output voltage changes exactly and immediately when changes occur in the load. This disturbance is equivalent to the case when the voltage control reference is changed. Therefore, the OCC-MR completely rejects load disturbances to the output voltage, and keeps the output voltage constant. Simulation results are shown in Fig. 11.

Figure 12 shows the vector operation of OCC-MR under un- balanced input voltage source. The phase voltage e_a is reduced by 20%, while the other two phase voltages e_b and e_c are kept unchanged. From the simulation results, it can be seen that, input current i_a is enlarged by 20%, while currents i_b and i_c are not changed. Therefore, the active power of each phase is identical like before. The THD of input current is 4.33%, which is larger than that under normal conditions. The output voltage also follows the control reference. So the OCC-MR can work well no matter the input voltage source is balanced or not. Since the OCC-MR is one kind of buck converter and the maximum linear voltage ratio is only 0.866, it doesn't work as expected if the RMS value of input voltage is less than the desired output voltage.

5. Conclusions

In this paper, a three-phase OCC-MR with vector operation is investigated. This converter provides a simple, effective and reliable rectification method. The OCC-MR use a three-phase

bridge as its power stage and two integrators with reset along with a few logic and linear components as its control core. The OCC controller is used to control input phase currents tracking input phase voltages. The power factor of OCC-MR is unity. By using vector operation, only two phase currents with smaller absolute value are switched at high frequency, while the phase current with the maximum absolute value is fixed ON or OFF in each region. Thus, the switching losses of whole converter are greatly lowered. The OCC-MR has rigid adaptability to the power system whether it is three-phase balanced or unbalanced and is capable of rejecting the load perturbations completely; the input phase currents are able to follow the control references within one cycle; and the switching error is automatically corrected within one cycle. There is neither steady state error nor dynamic error between the control reference and the average value of the input phase currents.

References

- [1] Holmes D.J., Lipo T.A., *Implementation of a Controlled Rectifier Using AC-AC Matrix Converter Theory*. IEEE Trans. on Power Electronics 7(1): 240-249 (1992).
- [2] Ejea J.B., Sanchis-Kilders E., Carrasco J.A. et al., *Implementation of bi-directional AC-DC matrix converter*. IEE Electronics Letters 38(16): 933-934 (2002).
- [3] Czerwinski C.S., *Control of a DC matrix converter*. United State Patent, P-6058028 (2000).
- [4] Yang X.J., Gong Y.M., *Investigations on Modular Three Phase-to-Single Phase Matrix Conversion Technique*. Power Electronics 36(5): 28-31 (2002) (in Chinese).
- [5] Alesina A., Venturini M.G.B., *Analysis and Design of Optimum-Amplitude Nine-Switch Direct AC-AC Converters*. IEEE Trans. On Power Electronics 4(1): 101-112 (1989).
- [6] Yang X.J., Ye P.S., Cai W., Gong Y.M., *Investigation on Switching Function Algorithm and Current SVM Algorithm of Matrix Rectifier*. Proceedings of the CSEE 26(24): 43-49 (2006) (in Chinese).
- [7] Ishiguro A., Furuhashi T., *A novel control method for forced commutated cycloconverters using instantaneous values of input line-to-line voltages*. IEEE Trans. On Industrial Electronics 38(3): 166-172 (1991).
- [8] Wang L., Chen X.Y., Xu D.G., *Research on closed-loop control for matrix converter based on double line-to-line voltages synthesis*. Proceedings of the CSEE 22(1): 74-79 (2002) (in Chinese).
- [9] Liu H.C., Chen X.Y., Feng Y. et al. *A research on common-mode voltage for matrix Converter based on two line voltage synthesis*. Proceedings of the CSEE 24(12): 182-186 (2004) (in Chinese).
- [10] Fang G., Irvani M.R., *Dynamic Model of a Space Vector Modulated Matrix Converter*. IEEE Trans. on Power Delivery 22(3): 1696-1705 (2007).
- [11] Chiang P., Blaabjerg L.F. et al. *Pulsewidth Modulation of Neutral Point Clamped Indirect Matrix Converter*. IEEE Trans. on Industry Applications 44(6): 1805-1814 (2008).
- [12] Bradaschia F., Cavalcanti M.C. et al. *A Modulation Technique to Reduce Switching Losses in Matrix Converters*. IEEE Trans. On Industrial Electronics 56(4): 1186-1195 (2009).
- [13] Muller S., Ammann U. et al. *New time-discrete modulation scheme for matrix converters*. IEEE Trans. on Industrial Electronics 52(6): 1607-1615 (2005).
- [14] Sangshin K., Toliyat H.A., *Development of modulation strategy for two-phase AC-AC matrix converters*. IEEE Trans. on Energy Conversion 20(2): 493-494 (2005).
- [15] Klumpner C., Blaabjerg F., *Modulation method for a multiple drive system based on a two-stage direct power conversion topology with reduced input current ripple*. IEEE Trans. on Power Electronics 20(4): 922-929 (2005).
- [16] Klumpner C., Blaabjerg F. et al. *New modulation method for matrix converters*. IEEE Trans. On Industry Applications 42(3): 797-806 (2006).
- [17] Yoon Y.D., Sul S.K., *Carrier-Based Modulation Technique for Matrix Converter*. IEEE Trans. on Power Electronics 21(6): 1691-1703 (2006).

- [18] Bina M.T., *Generalised direct positioning approach for multilevel space vector modulation: theory and DSP-implementation*. Electric Power Applications, IET 1(6): 915-925 (2007).
- [19] Smedley K.M., Čuk S., *One cycle control of switching converter*. IEEE Trans. On Power Electronics 10(6): 888-896 (1995).
- [20] Chen G.Z., Smedley K.M., *Steady-State and dynamic study of one-cycle-controlled three-phase power-factor correction*. IEEE Trans. On Industrial Electronics 52(2): 355-362 (2005).
- [21] Ghodke D.V., Sreeraj E.S., Chatterjee K., et al. *One-Cycle-Controlled Bidirectional AC-to-DC Converter With Constant Power Factor*. IEEE Trans. On Industrial Electronics 56(5): 1499-1510 (2009).
- [22] Chen Y., Smedley K.M., *One-Cycle-Controlled Three-Phase Grid-Connected Inverters and Their Parallel Operation*. IEEE Trans. On Industry Applications 44(2): 663-671 (2008).
- [23] Qiao C.M., Smedley K.M., *A general three-phase PFC controller for rectifiers with a parallel-connected dual boost topology*. IEEE Trans. On Power Electronics 17(6): 925-934 (2002).
- [24] Qiao C.M., Smedley K.M., *A general three-phase PFC controller for rectifiers with a series-connected dual-boost topology*. IEEE Trans. On Industry Applications 38(1): 137-148 (2002).
- [25] Yang C., Smedley K.M., *Parallel Operation of One-Cycle Controlled Three-Phase PFC Rectifiers*. IEEE Trans. On Industrial Electronics 54(6): 3217-3224 (2007).
- [26] Qiao C.M., Smedley K.M., *Three-phase unity-power-factor star-connected switch (VIENNA) rectifier with unified constant-frequency integration control*. IEEE Trans. On Power Electronics 18(4): 952-957 (2003).
- [27] Jin T.T., Li L.H., Smedley K.M., *A Universal Vector Controller for Four-Quadrant Three-Phase Power Converters*. IEEE Trans. On Circuits and Systems I: Regular Papers 54(2): 377-390 (2007).
- [28] Wheeler P., Grant D., *Optimised Input Filter Design and Low-Loss Switching Techniques for a Practical Matrix Converter*. IEE Electric Power Applications 144(1): 53-60 (1977).
- [29] Kume T., Yamada K., Higuchi T. et al., *Integrated Filters and Their Combined Effects in Matrix Converter*. IEEE Trans. On Industry Applications 43(2): 571-581 (2007).