

## SHORT TIME ALGORITHM OF POWER WAVEFORMS FUNDAMENTAL HARMONIC ESTIMATION WITH USE OF PRONY'S METHODS

Jarosław Zygarlicki<sup>1)</sup>, Janusz Mroczka<sup>2)</sup>

1) Opole University of Technology, Institute of Power Engineering, Prószkowska 76, 45-758 Opole, Poland (✉j.zygarlicki@po.opole.pl, +48 77 40 00 547)

2) Wrocław University of Technology, Chair of Electronic and Photonic Metrology, Bolesława Prusa 53/55, 50-317 Wrocław, Poland (✉janusz.mroczka@pwr.wroc.pl, +48 71 320 62 32)

### Abstract

This paper presents an example of practical use of Prony's method for monitoring of power waveform fundamental harmonic fluctuations, which is required for the analysis of window synchronizations in frequency analyses in power monitoring systems. The example presented offers verification of the authors' theoretical considerations published earlier in articles about Prony's method and its opportunities for practical use for real life signals. The investigations shown are based on the least squares Prony's method, which, in connection with digital filtrations, enables estimations of fundamental frequency at the rate of even tens of times per one fundamental harmonic period.

Keywords: Power quality, Prony's method, harmonics, measurements.

© 2011 Polish Academy of Sciences. All rights reserved

### 1. Introduction

The problem of precise estimation of fundamental harmonic frequency is very important for Fourier's analysis method used in power quality monitoring systems.

The estimating of frequency fluctuations in a short time window enables resampling the analyzed signal normalizing the frequencies of particular components so that they meet the frequencies of harmonics computed in Fourier transform. It is important for more accurate estimations of parameters of all harmonics in power waveforms [1, 2], especially for those systems which have a low stability of fundamental harmonics (power systems of ships and other closed power systems).

The popular algorithms for precise estimation of fundamental harmonic include spectral, adaptive filtering, mixed time and frequency domain, least-squares and eigenvector decomposition algorithms, etc. [3-5].

For precision short time analysis of power waveforms fluctuations, the authors decided to use Prony's method for reasons given below. The Prony analysis is a parametric method of large complexity. This method outperforms its Fourier transform counterpart [6, 7] in the accuracy of signal modeling and analysis for many practical signal processing situations. The advantages of LS Prony's method include precise estimation of frequency, amplitude and phase, in addition to the ability to compute damping coefficients for the signal components, which can be used for transient analysis.

The LS Prony's method is unfortunately very time consuming, because at each step it requires the inversion of large-size matrices, the rooting of a high-order polynomial, etc. In addition, problems occur sometimes with the numerical stability of a solution. The method is also known to behave poorly when a signal is corrupted with additive noise. Despite this fact, there are lots of examples of its application in power quality analysis [8-20].

The rest of this paper is organized as follows: Section 2 presents the LS Prony's method as well as the authors' algorithm for frequency of fundamental harmonic estimation; test simulation environment for the new method is described in Section 3 and performance of the method is also addressed there; new results of the paper are summarized in the conclusions of Section 4.

## 2. Method description

### 2.1. LS Prony's method

The LS Prony's method is based on the representation of a signal as a linear combination of exponential functions [21, 22]:

$$\hat{x}_n = \sum_{k=1}^p a_k \exp((\alpha_k + j2\pi f_k)(n-1)T + j\theta_k), \quad (1)$$

for  $n = 1, 2, \dots, N$ , where  $N$  – the length of signal,  $p$  – the number of exponentials,  $T$  – the sample interval in seconds,  $a_k$  – the amplitude of the complex exponentials,  $\alpha_k$  – the damping factor in seconds<sup>-1</sup>,  $f_k$  – the sinusoid frequency in Hz and  $\theta_k$  – the initial phase of the sinusoid in radians.

The block diagram of the least squares Prony's method is presented in Fig. 1.

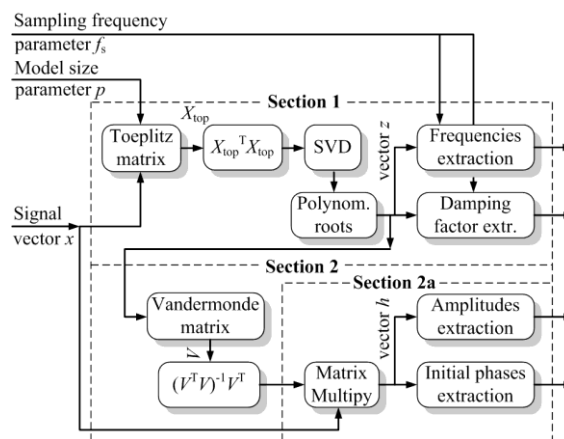

Fig. 1. The least squares Prony's method [8].

The computational algorithm is split into 2 parts. In the first part (Section 1), the Toeplitz matrix is computed, then the Singular Value Decomposition (SVD) is executed and the polynomial roots are extracted ( $z_k$ ). The frequencies and damping factors of the analyzed signal are calculated from the root vector  $z$ . In the next stage (Section 2), the Vandermonde matrix is calculated and the least squares method is used to estimate an unknown parameter vector  $h$ . This vector is used for computation of the amplitudes and initial phases for signal components.

### 2.2. Prony's method and filtering

The presented method, used for short time window power waveform fundamental harmonic estimation, is shown in Fig. 2. The presented algorithm enables also the estimations of the damping factor, as well as amplitudes and phases of analyzed signals, but in this paper only frequency analyses are included. Other analyses will be shown in subsequent

publications. The analysis of fundamental frequency fluctuations consists of, in the first step, signal filtering with adjusted band pass filter and, in the next step, Prony analysis (Section I, as per Fig. 1).

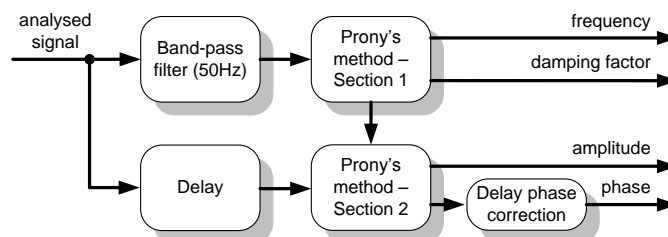

Fig. 2. The idea of precise fundamental harmonics estimation.

Fig. 3 presents Prony analysis of signal. Prony's method works as a moving window of 8 samples size for better harmonic approximations. The size of Prony's model is 2 because only one harmonic is estimated. For a sampling frequency of 25.6 kHz, the length of the analysis window is only  $Ta = 312.5 \mu s$ , which enables fluctuations of frequency harmonic estimations many times in each one-signal period.

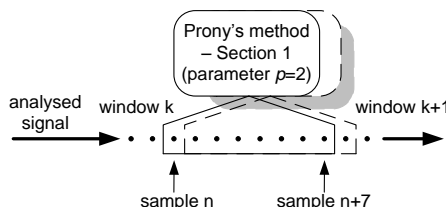

Fig. 3. Prony's method for fundamental harmonics estimation.

For the projected filter for signal analysis the authors made some basic assumptions:

- maximum linearity in the pass band – the authors chose the Butterworth filter,
- pass band around 50Hz – Prony's method is a very sensitive one and therefore absorption of over a dozen dB does not significantly affect harmonic detection,
- a very high stop magnitude for other harmonics eliminations,
- frequency of stop bands below the frequency of next harmonics,
- low order of the filter for fast computations – the authors chose the IIR class of filters.

The parameters of projected filters, adjusted according to presented assumptions, are shown in Table 1. Fig. 4 and 5 shows the magnitude response of the constructed filter.

Table 1. Filter description – Fig. 4, 5.

Filter type	Butterworth IIR filter	
Sampling frequency	$f_s =$	25600 Hz
Stop frequency 1	$f_{stop1} =$	25 Hz
Pass frequency 1	$f_{pass1} =$	49.5 Hz
Pass frequency 2	$f_{pass2} =$	50.5 Hz
Stop frequency 2	$f_{stop2} =$	90 dB
Stop magnitude 1	$A_{stop1} =$	90 dB
Pass magnitude	$A_{pass} =$	1 dB
Stop magnitude 2	$A_{stop2} =$	90 dB
Filter order	$order =$	6
Filter section	$section =$	3

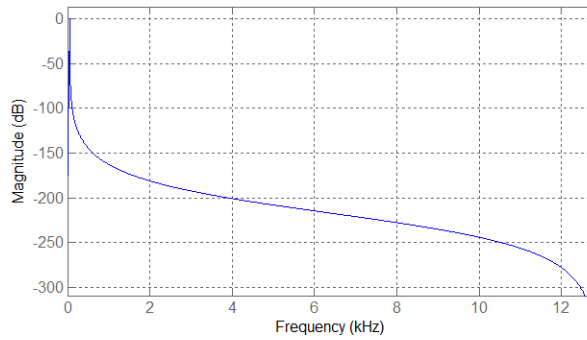

Fig. 4. Magnitude response of band pass filter.

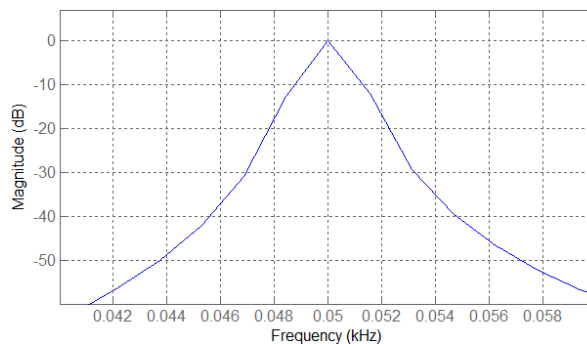

Fig. 5. Magnitude response of band pass filter – zoom in pass band.

### 2.3. Measurement methods

Figs 6 – 8 present three measurement methods used in the investigations:

1. In Fig. 6 the test signal is generated and, after adding noise, analyzed in Matlab – this enables estimation of noise influence.
2. In Fig. 7 the signal is generated in Matlab, then converted from digital to analog with multifunction DAQ, next the analog signal is amplified, then passed through the calibrated voltage divider circuit with galvanic isolation and, in the last steps, converted to digital form and analyzed in Matlab – it enables estimation of the accuracy of the presented method in real life systems.
3. In Fig. 8, the real life power waveform is archived and analyzed with the use of a calibrated voltage divider circuit with galvanic isolation, multifunction DAQ and Matlab environment – it enables the observation of frequency fluctuations in a real life power network system.

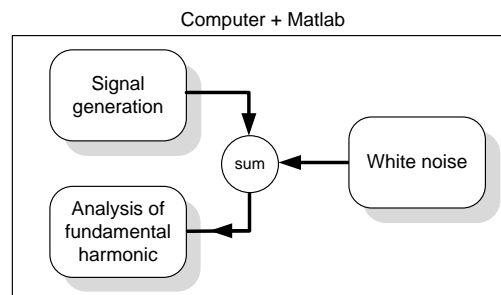

Fig. 6. Waveform generation and analysis system.

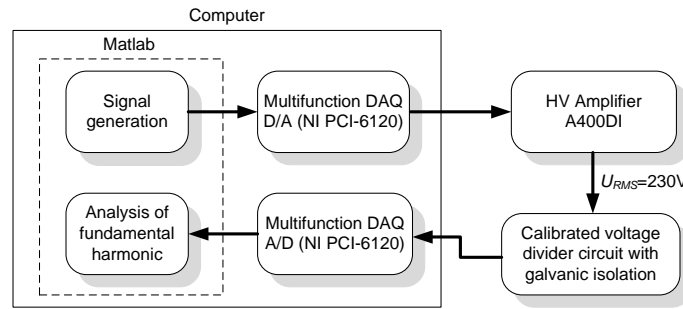

Fig. 7. Power waveforms generation and acquisition system.

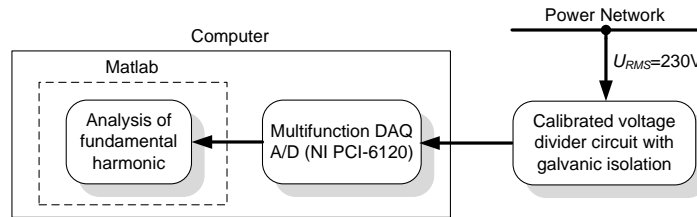

Fig. 8. Power waveforms acquisition system.

### 3. Results

In the articles, the authors focused on the accuracy estimation of the described method, which is the most important for applications presented in the introduction. Analysis of the accuracy of estimation of other parameters such as: amplitudes, damping factors and initial phases will be shown in a subsequent publication. Table 2 shows compositions of estimated frequency precision for different measurement methods and signals. The results obtained prove the high accuracy of the presented method even for a signal with a high level of noise ( $3\sigma = 153.0 \mu\text{Hz}$  for 40dB signal to noise ratio).

Table 2. Estimated precision for a variety of types of measurements and signals (analysis window –  $Ta=312.5 \mu\text{s}$ ).

Signal type	acquisition system	$\sigma$	estimated precision (uncertainty) $3\sigma$
Signal simulated ( $f=50\text{Hz}$ ) without noise	Figure 6	2.60 $\mu\text{Hz}$	7.80 $\mu\text{Hz}$
Signal simulated ( $f=50\text{Hz}$ ) with 40 dB signal-to-noise ratio	Figure 6	51.0 $\mu\text{Hz}$	153.0 $\mu\text{Hz}$
Signal simulated ( $f=50\text{Hz}$ ), generated and recorded with NIDAQ	Figure 7	20.3 $\mu\text{Hz}$	60.9 $\mu\text{Hz}$
Signal simulated ( $f=51\text{Hz}$ ), generated and recorded with NIDAQ	Figure 7	37.3 $\mu\text{Hz}$	111.9 $\mu\text{Hz}$
Signal simulated ( $f=49\text{Hz}$ ), generated and recorded with NIDAQ	Figure 7	31.1 $\mu\text{Hz}$	93.3 $\mu\text{Hz}$

Where:  $\sigma$  – standard deviation of measurements,  $3\sigma$  – uncertainty for 99.73% of values expected.

In comparison, the precision obtained with simply the zero-crossing detection method (Fig. 9) used for fundamental harmonic estimation is about:

$$\Delta \hat{f}_{H0} = |f_{H0} - \hat{f}_{H0}| \approx 97.5 \text{ mHz}, \quad (2)$$

for:

$$\hat{f}_{H0} = 1/\hat{T}_{H0} = 49.90253\text{Hz},$$

$$\begin{aligned} \hat{T}_{H0} &= T_{H0} + T_s = 20.0390625\text{ms} , \\ T_{H0} &= 1/ f_{H0} = 20\text{ms} , \\ T_s &= 1/ f_s = 39.0625\mu\text{s} , \end{aligned}$$

where:

$f_s$  – sampling frequency,  $f_{H0}$ – frequency of fundamental harmonic,  $\hat{f}_{H0}$ – estimated frequency of fundamental harmonic.

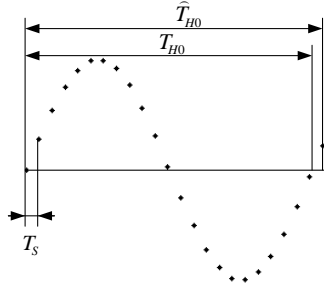

Fig. 9. Zero-crossing detection method for fundamental harmonic frequency estimation.

The results presented show a significant advantage of the discussed method, with accuracy much better than the zero-crossing detection method.

Figs. 10-14 present the recorded frequency fluctuations for simulated signals. Figs. 15-17 present the recorded frequency fluctuations for real life power waveforms. All figures have the same frequency axis range for better observation of differences between individual measurements.

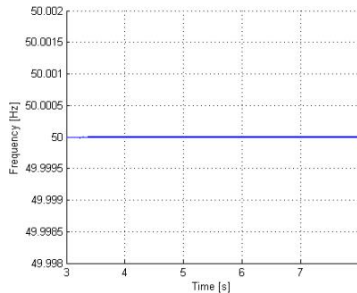

Fig. 10. Recorded frequency fluctuations of simulated signal without noise, (fundamental harmonics  $f=50$  Hz, estimated precision  $3\sigma = 7.80 \mu\text{Hz}$ ).

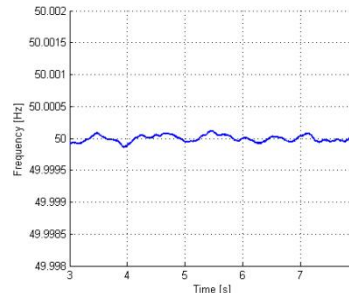

Fig. 11. Recorded frequency fluctuations of simulated signal with white noise, (fundamental harmonics  $f=50$  Hz, estimated precision  $3\sigma = 153.0 \mu\text{Hz}$ ).

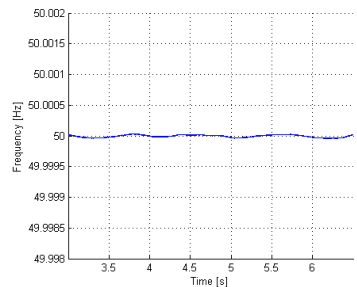

Fig. 12. Recorded frequency fluctuations of generated signal with NIDAQ, fundamental harmonics  $f=50$  Hz, estimated precision  $3\sigma = 60.9 \mu\text{Hz}$ ).

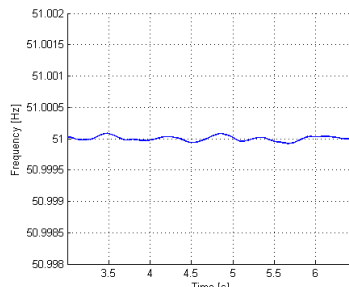

Fig. 13. Recorded frequency fluctuations of generated signal with NIDAQ, (fundamental harmonics  $f=51$  Hz, estimated precision  $3\sigma = 111.9 \mu\text{Hz}$ ).

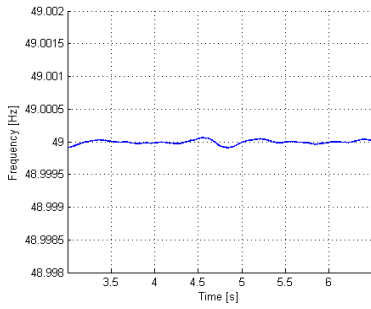

Fig. 14. Recorded frequency fluctuations of generated signal with NIDAQ, (fundamental harmonics  $f=49$  Hz, estimated precision  $3\sigma = 93.3 \mu\text{Hz}$ ).

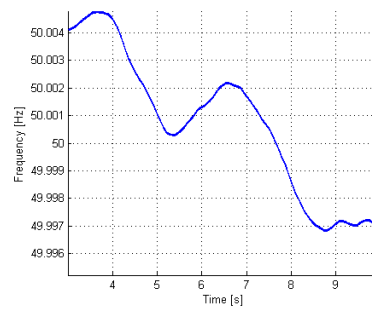

Fig. 15. Recorded frequency fluctuations of real life power waveforms – example 1.

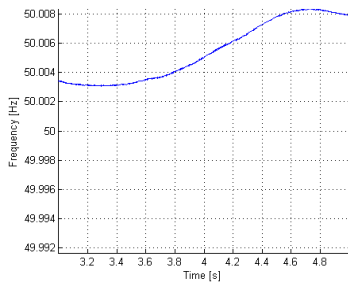

Fig. 16. Recorded frequency fluctuations of real life power waveforms – example 2.

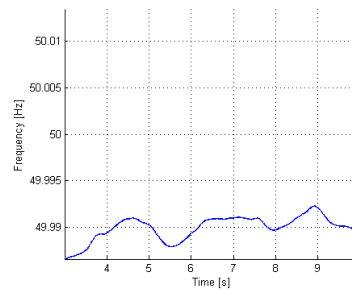

Fig. 17. Recorded frequency fluctuations of real life power waveforms – example 3.

## 4. Conclusions

The problem of precise estimation of fundamental harmonic frequency is very important for Fourier's analysis methods used in power quality monitoring systems. Simple methods such as zero-crossing detection do not offer enough precision, which was proved in the paper. The investigations made show new opportunities to improve the accuracy of measurements for methods currently in use in real time power quality monitoring systems. The estimation of frequency fluctuations in a short time window enables resampling the analyzed signal that normalizes the frequencies of particular components so that they meet those computed in Fourier transform harmonics. It ensures obtaining Fourier analysis window synchronizations on a very high level that is required for precision computation of harmonics parameters, even for difficult frequency fluctuations in the analyzed window. The results lead to subsequent research. Improving the accuracy of measurements conducted under this method for a variety of types of analyzed signals will be the subject of subsequent articles, but these very preliminary investigations show the opportunity for use of the presented method especially in those systems which have a low stability of fundamental harmonics (power systems of ships and other closed power systems), where power quality measurements are a difficult task to perform.

## Acknowledgements

This work was supported by the Ministry of Science and Higher Education, Poland (grant # N N505 557439).

## References

- [1] Szmajda, M., Górecki, K., Mroczka, J. (2010). Gabor transform, SPWVD, Gabor-Wigner transform and wavelet transform - tools for power quality monitoring. *Metrol. and Meas. Syst.*, 16(3), 383-396.
- [2] Ming, Z., Kaicheng, L., Yisheng, H. (2010). DSP-FPGA based real-time power quality disturbances classifier. *Metrol. and Meas. Syst.*, 17(2), 205-216.
- [3] Ramos, P.M., Cruz Serraa, A. (November 2009). Comparison of frequency estimation algorithms for power quality assessment. *Measurement*, 42(9), 1312-1317.
- [4] Liu, S. (October 1998). An adaptive Kalman filter for dynamic estimation of harmonic signals. *8th International Conference On Harmonics and Quality of Power, ICHQP '98*, Athens, Greece, 636-640.
- [5] Joorabian, M., Mortazavia, S.S., Khayyami, A.A. (January 2009). Harmonic estimation in a power system using a novel hybrid Least Squares-Adaline algorithm. *Electric Power Systems Research*, 79(1), 107-116.
- [6] Lobos, T., Leonowicz, Z., Rezmer, J., Schegner P. (February 2006). High-resolution spectrum-estimation methods for signal analysis in power systems. *IEEE Trans. Instrum. Meas.*, 55(1), 219-225.
- [7] Meunier, M., Brouaye, F. (October 1998). Fourier transform, wavelets, Prony analysis: Tools for harmonics and quality of power. *Proc. Int. Conf. on Harmonics Quality of Power*, Athens, Greece, 71-76.
- [8] Zygarlicki, J., Zygarlicka, M., Mroczka, J., Latawiec, K. (April 2010). A reduced Prony's method in power quality analysis – parameters selection. *IEEE Transactions on Power Delivery*, 25(2), 979-986.
- [9] Zygarlicki, J., Mroczka, J. (September 2006). Data compression using Prony's method and wavelet transform in power quality monitoring systems. *Metrol. and Meas. Syst.*, 13(3), 237-251.
- [10] Zygarlicki, J., Zygarlicka, M., Mroczka, J. (December 2009). Prony's method in power quality analysis. *Energy Spectrum*, 4(2), 26-30.
- [11] Zygarlicki, J., Mroczka, J. (September 2009). Analysis of electrical signals using Prony method and the combined M-band filter. *Modeling and simulation of Measurement Systems*, Krynica, 37-46. (in Polish)
- [12] Zygarlicki, J., Zygarlicka, M., Mroczka, J. (2008). Prony's method in power quality analysis. *Proc. 9th Int. Scientific Conf. Electric Power Engineering*, Brno, Czech Republic, 115-119.
- [13] Costa, R.E., de Almeida, L.A.L., Wegelin, E. A., da Costa, E.G. (May 2005). Recursive Prony's Method for Improving the Monitoring of Electrical Machines. *IMTC 2005 - Instrumentation and Measurement, Technology Conference*, Ottawa, Canada, 1498-1502.
- [14] Costa, F.F., Cardoso, A.J.M., Fernandes, Darlan A. (April 2007). Harmonic Analysis Based on Kalman Filtering and Prony's Method. *POWERENG 2007*, Setubal, Portugal, 696-701.
- [15] Costa, F.F., Fernandes, D.A., de Almeida, L.A.L., Naidu, S.R. (2005). Prony's Method versus FFT for Analyzing Power Converters Signals. *EPE – Power Electronics and Applications*, Dresden, 11-14.
- [16] Feilat, E.A. (October 2006). Detection of voltage envelope using Prony analysis-Hilbert transform method. *IEEE Trans. Power Del.*, 21(4), 2091-2093.
- [17] Feilat, E.A. (October 2006). Prony analysis technique for estimation of the mean curve of lightning impulses. *IEEE Trans. Power Del.*, 21(4), 2088-2090.
- [18] Leonowicz, Z., Lobos, T., Rezmer, J. (June 2003). Advanced spectrum estimation methods for signal analysis in power electronics. *IEEE Trans. Ind. Electron.*, 50(3), 514-519.
- [19] Lobos, T., Leonowicz, Z., Rezmer, J., Koglin, H.J. (2001). Advanced signal processing methods of harmonics and interharmonics estimation. *Proc. 7th Int. Conf. Developments in Power System Protection*, Amsterdam, The Netherlands, 315-318.
- [20] Zhijian, Hu, Jianquang, Guo, Mei, Yu, Zhiwei, Du, Chao, Wang. (October 2006). The Studies on Power System Harmonic Analysis based on Extended Prony Method. *2006 International Conference on Power Systems Technology (POWERCON)*, Chongqing, China, 22-26.
- [21] Marple, S., Lawrence, J. (1987). *Digital Spectral Analysis*. Englewood Cliffs, NJ: Prentice-Hall.
- [22] Osborne, M.R., Smith, G.K. (January 1995). A modified Prony algorithm for exponential function fitting. *SIAM J. Scientific Comput.*, 16(1), 119-138.