

VELOCITY MEASUREMENT USING THE FDOA METHOD IN GROUND-BASED RADIO NAVIGATION SYSTEM

Jarosław Sadowski

Gdansk University of Technology, Faculty of Electronics, Telecommunications and Informatics, Department of Radio Communication Systems and Networks, Narutowicza 11/12, 80-233 Gdansk, Poland (✉ jarsad@eti.pg.gda.pl, +48 58 347 17 73)

Abstract

Velocity is one of the main navigation parameters of moving objects. However some systems of position estimation using radio wave measurements cannot provide velocity data due to limitation of their performance. In this paper a velocity measurement method for the DS-CDMA radio navigation system is proposed, which does not require full synchronization of reference stations carrier frequencies. The article presents basics of FDOA (frequency difference of arrival) velocity measurements together with application of this method to an experimental radio navigation system called AEGIR and with some suggestions about the possibility to implement such FDOA measurements in other kinds of asynchronous DS-CDMA radio networks. The main part of this paper present results of performance evaluation of the proposed method, based on laboratory measurements.

Keywords: radio navigation, spread spectrum, velocity estimation, FDOA.

© 2014 Polish Academy of Sciences. All rights reserved

1. Introduction

As a result of development project no. O R00 0049 06 (financially supported by the Polish Ministry of Science and Higher Education), an experimental ground-based radio navigation (radio location) system called AEGIR (in Norse mythology: god of the ocean) was designed and constructed in the form of a technology demonstrator in the laboratory of Department of Radio Communication Systems and Networks in Gdansk University of Technology. This system was designed as a navigational aid for use on navy ships in case of unavailability of position data from other sources, such as satellite navigation systems (GPS/GLONASS). Although this project has been finished in 2011, the radio navigation system is still under development. Main goals of the current work on this system are to improve accuracy of position estimation and to offer new functionality. Both tasks can be met by implementing navigation receiver (ship) velocity measurement. The velocity of the receiver may then be used for two purposes: directly as navigation data for navigation service and as a source of additional independent data for filtering navigational data (measured by the TDOA method) using a Kalman filter.

This paper presents velocity measurement using the FDOA (frequency difference of arrival) method, implemented in radio navigation system AEGIR. In radio navigation systems only two methods of velocity components estimation are used in practice: Doppler shift-based calculation of velocity from changes in observed carrier frequency, and estimation of velocity as a derivative of distance in time. The second method has one significant drawback: as the velocity is calculated from position measurements, it cannot be treated as independent data (with independent measurement error) and used to improve position estimation for example via Kalman filtering. That was the reason for an attempt to modify the

FDOA method to estimate the velocity of a moving receiver from Doppler shift measurements of not fully synchronized base station transmitters.

Although implementation of velocity measurement was not a part of development project which was already finished, frequency estimation procedures required for velocity calculation were designed strictly for radio signals used in this system, so a description of the AEGIR system and structure of radio signals is necessary to clarify limitations of velocity estimation in this implementation. However, the proposed FDOA velocity measurement method does not require the base stations of the radio network (reference stations) to be fully synchronized, so the proposed method and algorithms can be implemented in other synchronous and asynchronous DS-CDMA radio networks, even not designed for radio navigation purposes.

Next parts of this paper focus on velocity estimation from measurements of received signal carrier frequencies and frequency measurements of DS-CDMA signals. The efficiency of the proposed velocity estimation method was evaluated in laboratory tests, which are described in detail at the end of the paper. Also the tests were carried out with the assumption that velocity is measured in the AEGIR system, but the presented results may be used to estimate possible accuracy of velocity measurements in other systems with similar physical layer, such as CDMA cellular phone networks.

2. Ground-based radio navigation system AEGIR

Radio navigation system AEGIR was built as a technology demonstrator composed of three transmitters and one receiver which use direct sequence code division multiple access spread spectrum signals [1][2]. Reference transmitters are not synchronized (they are clocked by free-running rubidium reference oscillators), so in order to allow position calculation based on time difference of arrival (TDOA) measurements, at least one reference station has to be able to receive signals from other stations, measure time differences between characteristic parts in these signals and then transmit time difference data to the navigation receiver [3]. The reference station which is able to receive signals from other stations is called "Full reference station", while "Simplified reference stations" are made only of a DS-CDMA transmitter, without a receiving part (Fig. 1.). It is obvious that in real conditions more than three reference stations may be needed to cover the whole area of operation (e.g. coastal zone of one country), but to offer navigation service, the receiver has to be able to receive signals from at least three stations, while at least one of them is a full reference station. Further analysis in this paper will be presented only for a three-base-stations scenario, however the proposed method of velocity measurement can be easily extended to a higher number of base stations.

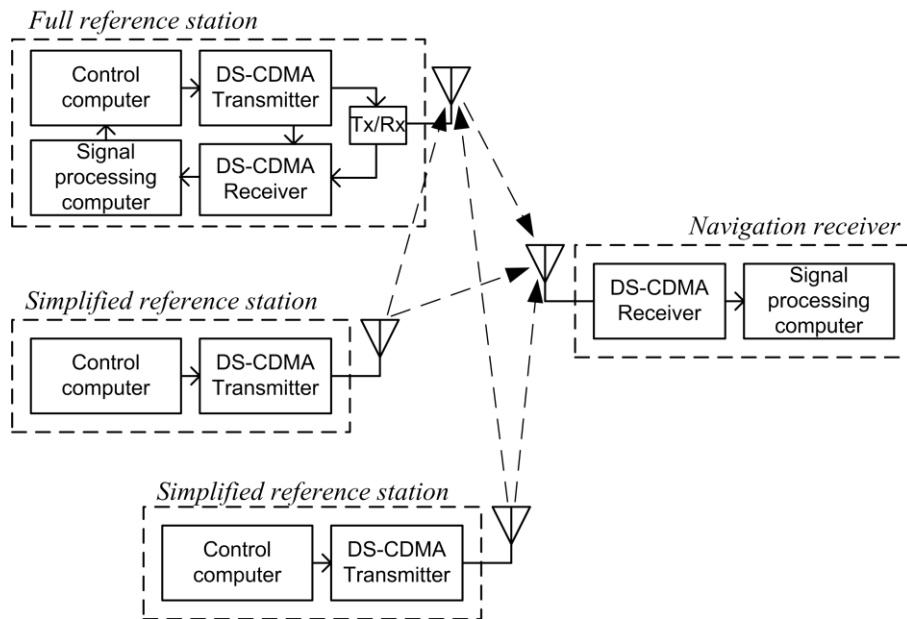

Fig. 1. General structure of AEGIR radio navigation system.

To allow reception of signals from other stations in the full reference station, and also to reduce the impact of near-far problem on the availability of the navigation service in proximity to base stations, transmitters are periodically switched off for a time greater than that required to receive a whole radio packet with important data required for position calculation in the receiver. All reference stations transmit two kinds of data packets in a continuous stream: primary location data (PLD) and extended location data (ELD). The PLD packets in all reference stations contain information about the position of the transmitter and signal parameters. The ELD from a full reference station contain information about time differences between signals transmitted from different stations, while ELD from a simplified reference station is just a copy of the PLD data. Both data packets are divided into 26-bit fragments separated by 13-bit synchronization fields (Barker sequence), which creates a 39-bit elementary frame structure as presented in Fig. 2. All data and sync bits in elementary frame are spread by a 1024-chip long fragment of pseudo-random sequence (39936 chip total length), different for all base stations and different for PLD and ELD data. Data rate is equal to 1kb/s. Channel coding and data encryption are not important in velocity measurements and will not be described here. The proposed velocity measurement method will be also valid for other kind of DS-CDMA radio networks [4].

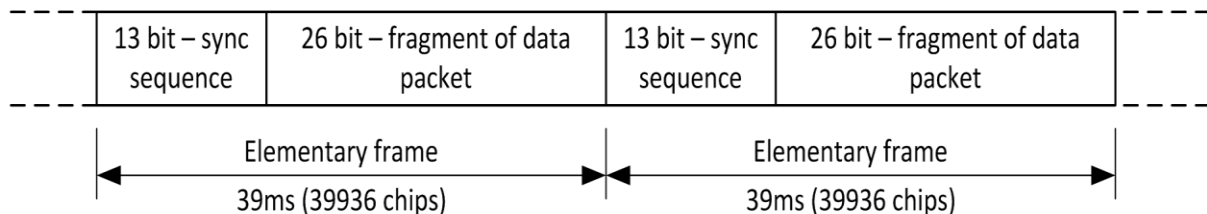

Fig. 2. Time structure of transmitted radio signals.

3. Implementation of velocity estimation in AEGIR system

3.1. Concept of velocity measurement using the FDOA method

Although velocity estimation using frequency difference of arrival method (also known as differential Doppler) is already documented in literature [5], some description of FDOA basics in the proposed implementation is still needed because the AEGIR system is not fully synchronous. Consider a set of three base stations, marked A (full reference station), B and C (simplified reference stations) and navigation receiver, as presented in Fig. 3

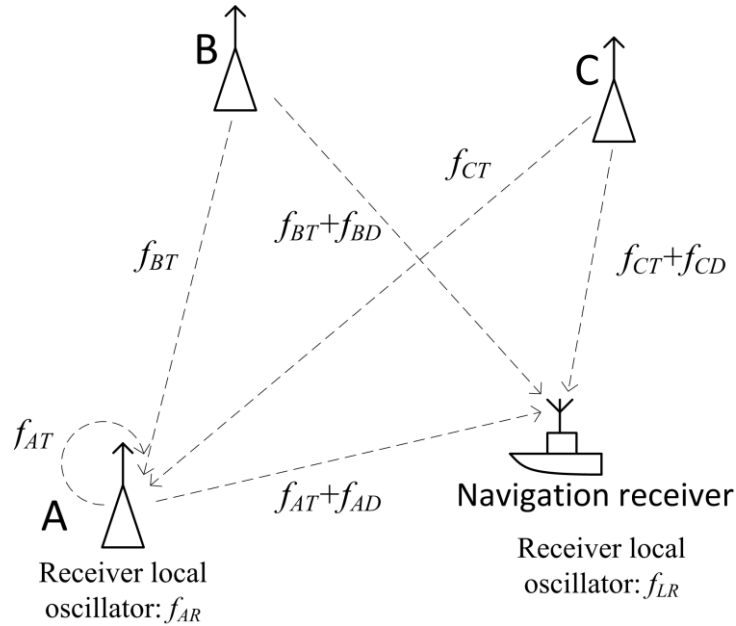

Fig. 3. Illustration of frequencies important in navigation receiver velocity calculation.

The frequency of radio signals received by the navigation receiver differ from transmitted frequencies due to Doppler shift. Frequencies marked in Fig. 3 have the following meaning:

- f_{AT} – transmitter A carrier frequency
- f_{BT} – transmitter B carrier frequency
- f_{CT} – transmitter C carrier frequency
- f_{AR} – local oscillator frequency in receiver in full reference station A
- f_{AD} – Doppler shift of station A frequency due to movement of navigation receiver
- f_{BD} – Doppler shift of station B frequency due to movement of navigation receiver
- f_{CD} – Doppler shift of station C frequency due to movement of navigation receiver
- f_{LR} – local oscillator frequency in navigation receiver

In most of possible receiver structures, the receiver cannot directly measure the frequency of incoming signals with resolution higher than the precision of its reference oscillator, typically 10^{-7} . This resolution is too low for direct measurement of Doppler shift, however it is possible to precisely measure the difference between frequency of the received signal and the frequency of receiver's local oscillator with an accuracy limited by short time stability of this oscillator. In full reference station A it is possible to measure differences:

$$\delta_{AT} = f_{AT} - f_{AR}, \quad (1)$$

$$\delta_{BT} = f_{BT} - f_{AR}, \quad (2)$$

$$\delta_{CT} = f_{CT} - f_{AR}, \quad (3)$$

and in a navigation receiver:

$$\delta_{AR} = f_{AD} + f_{AT} - f_{LR}, \quad (4)$$

$$\delta_{BR} = f_{BD} + f_{BT} - f_{LR}, \quad (5)$$

$$\delta_{CR} = f_{CD} + f_{CT} - f_{LR}. \quad (6)$$

Real frequencies of receivers' local oscillators f_{AR} i f_{LR} are unknown and have to be removed from calculations:

$$(f_{BT} - f_{AR}) - (f_{AT} - f_{AR}) = f_{BT} - f_{AT}, \quad (7)$$

$$(f_{CT} - f_{AR}) - (f_{AT} - f_{AR}) = f_{CT} - f_{AT}. \quad (8)$$

These differences between frequencies of signals transmitted from adjacent stations, measured in station A, should be included in the ELD data packet sent to mobile navigation receivers. A navigation receiver can calculate:

$$(f_{BD} + f_{BT} - f_{LR}) - (f_{AD} + f_{AT} - f_{LR}) = (f_{BD} + f_{BT}) - (f_{AD} + f_{AT}), \quad (9)$$

$$(f_{CD} + f_{CT} - f_{LR}) - (f_{AD} + f_{AT} - f_{LR}) = (f_{CD} + f_{CT}) - (f_{AD} + f_{AT}). \quad (10)$$

Finally, Doppler shift differences $f_{BD}-f_{AD}$ and $f_{CD}-f_{AD}$ can be calculated by subtracting (7), (8) from (9), (10). These frequency differences should be converted to differences in velocity components in directions from receiver to base stations: v_B-v_A and v_C-v_A (Fig. 4).

$$v_B - v_A = c \cdot \frac{f_{BD} - f_{AD}}{f_0}, \quad (11)$$

$$v_C - v_A = c \cdot \frac{f_{CD} - f_{AD}}{f_0}. \quad (12)$$

Frequency f_0 is equal to the nominal centre frequency of transmitted signals (differences between real frequencies f_{xT} and nominal system frequency f_0 are unimportant at this step of calculations).

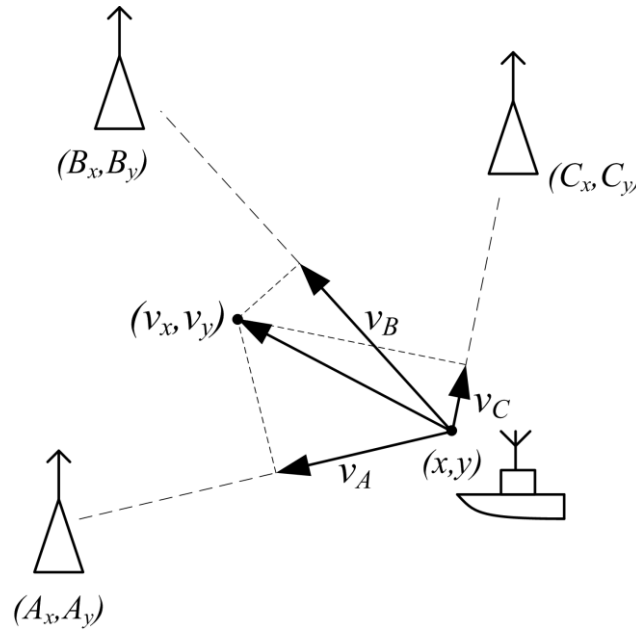

Fig. 4. Geometry of velocity vector components.

Relation between Doppler shift frequencies and the receiver velocity vector depends on the geometry of base stations and the position of the navigation receiver. Assuming that $A_x, A_y, B_x, B_y, C_x, C_y$ are Cartesian coordinates of base stations and x, y are coordinates of the receiver, the following equations are valid:

$$v_B - v_A = \frac{v_x(B_x - x) + v_y(B_y - y)}{\sqrt{(B_x - x)^2 + (B_y - y)^2}} - \frac{v_x(A_x - x) + v_y(A_y - y)}{\sqrt{(A_x - x)^2 + (A_y - y)^2}}, \quad (13)$$

$$v_C - v_A = \frac{v_x(C_x - x) + v_y(C_y - y)}{\sqrt{(C_x - x)^2 + (C_y - y)^2}} - \frac{v_x(A_x - x) + v_y(A_y - y)}{\sqrt{(A_x - x)^2 + (A_y - y)^2}}, \quad (14)$$

where v_x and v_y are Cartesian components of the velocity vector which can be obtained by solving a set of linear equations (13) and (14).

3.2. DS-CDMA carrier frequency measurement in the AEGIR system

From all known methods of carrier signal recovery [6] only few are applicable to DS-CDMA systems. Many important details about carrier synchronization can be read in publications describing GPS receiver structure, but the author decided to implement a carrier frequency measurement method customized to fit the AEGIR system signals' structure. Because the precision of velocity estimation using FDOA methods depends directly on the precision of Doppler frequency shift measurements, this chapter focuses on evaluation of the proposed carrier frequency measurement method.

When the data stream bit sequence is known (during the reception of a known, fixed synchronization sequence or when the data stream is already demodulated in another part of the receiver), the carrier frequency can be calculated as a derivative of despread I/Q symbol phases after phase inversion required to remove modulation. But from the other side: carrier frequency estimation is required to demodulate the unknown part of the received signal (data

stream, between sync fields), so the demodulation and frequency estimation tasks are strictly connected, as presented in the receiver block diagram in Fig. 5.

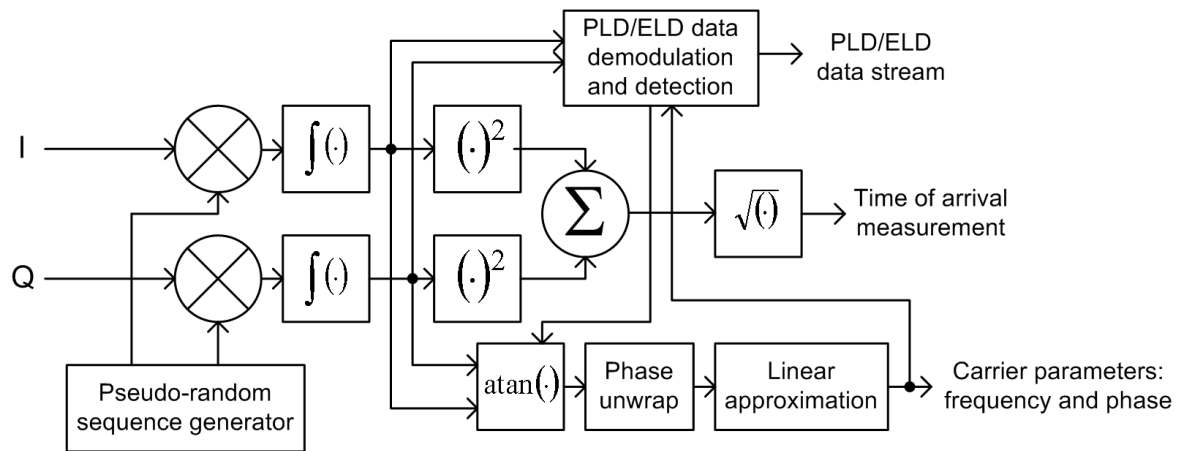

Fig. 5. Proposed block diagram of a receiver with carrier frequency estimation based on linear approximation of symbols' phases.

An AEGIR navigation receiver is able to precisely measure the time of arrival for every 39-bit long part of received DS-CDMA signals and therefore also the position of this receiver can be calculated independently every 39ms. To provide synchronous position and velocity data for the Kalman filter, carrier frequency measurements are made separately for every elementary frame. The sequence of tasks performed by the navigation receiver to estimate Doppler shift and by the receiver in a full reference station to estimate carrier synchronization errors between base stations is as follows (example of reception of a DS-CDMA signal from one station, PLD and ELD data stream):

- Despread signals I and Q separately for every 39 symbols, using PLD and ELD pseudorandom sequences,
- Roughly estimate the carrier frequency and initial phase basing on 13-bit synchronization sequence (calculate the difference between ideal and received symbol phases, unwrap phases and approximate by a linear equation),
- Demodulate and detect the remaining 26 bits in a PLD and ELD data stream using carrier estimation from the previous step,
- Remove modulation from symbol phases ($\pm\pi$ correction depending on detected data),
- Unwrap phases beyond the $\pm\pi$ limit,
- Approximate phases by a linear equation using the least squares method (PLD and ELD independently).

The required carrier frequency estimation is equal to averaged PLD and ELD phases linear approximation coefficient.

Because base stations are clocked by a rubidium frequency source, differences in carrier frequencies measured by the receiver in a full reference station are varying very slowly. To reduce velocity estimation errors caused by $f_{BT}-f_{AT}$ and $f_{CT}-f_{AT}$ in (9) and (10), frequency differences from the reference receiver are filtered in a moving average filter with at least 30s averaging time before sending them to a navigation receiver in ELD packets. Carrier frequencies measured by the navigation receiver are being used directly to calculate current velocity, without additional filtering.

4. Laboratory measurement set

In order to evaluate the precision and accuracy of the proposed FDOA velocity measurement method, a laboratory source of AEGIR base station signals was built using an arbitrary waveform generator R&S AFQ100. A set of I/Q samples, prepared by dedicated software, can represent any positions of reference stations, with any carrier frequency error in a range of $\pm 250\text{Hz}$ and relative power of signals from different stations in a range of $\pm 40\text{dB}$. The baseband signal from the arbitrary waveform generator is up-converted to the nominal frequency of $431,5\text{MHz}$ (frequency assigned to the AEGIR technology demonstrator by the Polish Office of Electronic Communications) in the R&S SMBV100 vector signal generator. To ensure high frequency stability, the same frequency source FS725 which was a part of AEGIR transmitters, is used to clock both generators.

To measure the immunity of the proposed FDOA method to navigation receiver local oscillator frequency error, an EM550 receiver (main part of both navigation receiver and reference receiver in a full reference station) is connected to an additional RF generator, which may be used to clock the EM550 by a reference clock with controlled frequency error. The receiver reference frequency can be set with a $0,01\text{Hz}$ step (10^{-9} relative resolution of EM550 local oscillator frequency settings).

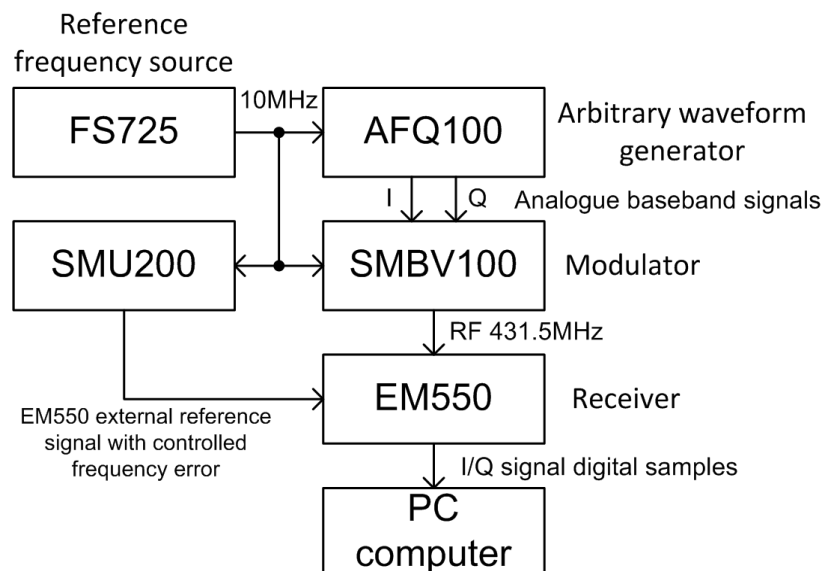

Fig. 6. Laboratory equipment used to evaluate precision and accuracy of FDOA velocity measurement.

5. Evaluation of carrier frequency measurement in laboratory conditions

All base station transmitters in the AEGIR system are clocked by free-running rubidium reference oscillators (no synchronization), but installation of such a highly stable reference clock in navigation receivers is impractical due to its size, weight and cost. To ensure that the assumption of short-term receiver local oscillator stability is valid, additional measurement of EM550 receiver local oscillator frequency was conducted using the equipment presented in Fig. 6. During this measurement, the SMBV100 was generating a continuous wave signal with a frequency of 431.50005MHz while the EM550 was tuned to 431.5MHz . A set of I/Q samples from the receiver was used to measure the frequency shift by looking for the highest value of DFT (Discrete Fourier Transform) separately in every $0,5\text{s}$ period. The measured frequency shift for a receiver clocked by an internal reference clock varied from $11,29\text{ Hz}$ to $12,24\text{ Hz}$ with a mean value of $11,74\text{ Hz}$, while the receiver synchronized by an external

rubidium clock had a frequency offset from $-0,003$ Hz to $+0,003$ Hz with a mean value -5×10^{-6} Hz.

Although a receiver internal oscillator frequency changes during receiver warming, its short term stability defined as the difference between maximal and minimal value of frequency shift in a short period (e.g. 10s), $\Delta f_{max} - \Delta f_{min}$ referred to carrier frequency f_0 is approximately constant and ten times higher than for a receiver synchronized by a rubidium clock (Fig. 7). Oscillator stability may be also expressed by means of the Allan variance [7][8]. Skipping the first 60 seconds of measurements (fast frequency change period of the internal oscillator) the Allan variance for the receiver's internal reference clock was equal to $1.56 \times 10^{-4} \text{ Hz}^2$ while for a receiver synchronized to an external clock this variance was equal to $1.22 \times 10^{-5} \text{ Hz}^2$. Both values are low enough to ignore the clock instability in FDOA measurement error analysis.

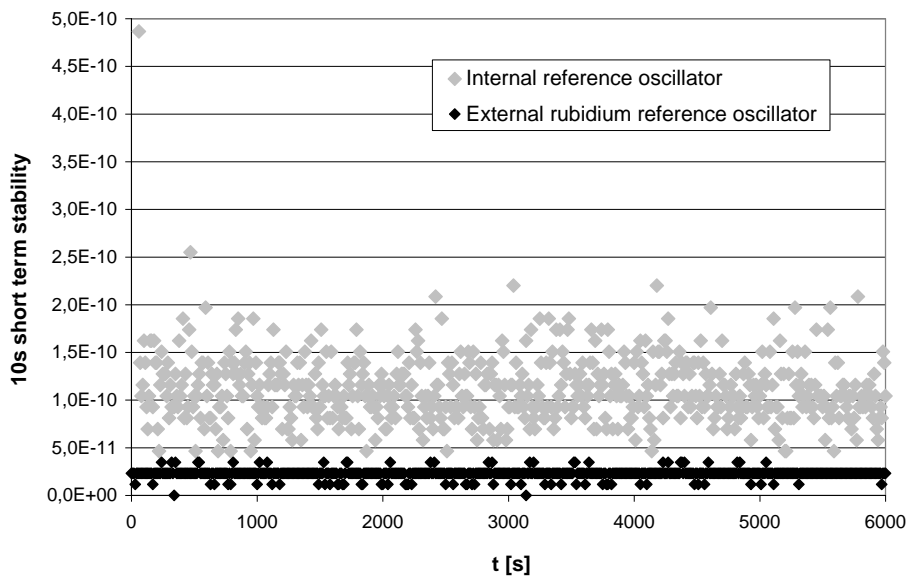

Fig. 7. Receiver oscillator relative frequency stability in time.

In DS-CDMA radio communication systems, the quality of reception depends on the signal to noise ratio for low signal power at the input of the receiver, and on the signal to interference ratio for stronger signals. Because the same rules apply to radio location and navigation systems, mean error and standard deviation of carrier frequency shift measurements were tested in the laboratory for different levels of base station signals. Fig. 8 presents the frequency shift measurement errors as a function of signal level at the input of the receiver, equal for all three stations. One station signal consists of two streams: PLD and ELD with equal power, the power of the signal presented in Fig. 8 refers to the total power of one station PLD/ELD signal. During this measurement the EM550 receiver was synchronized by an external reference clock.

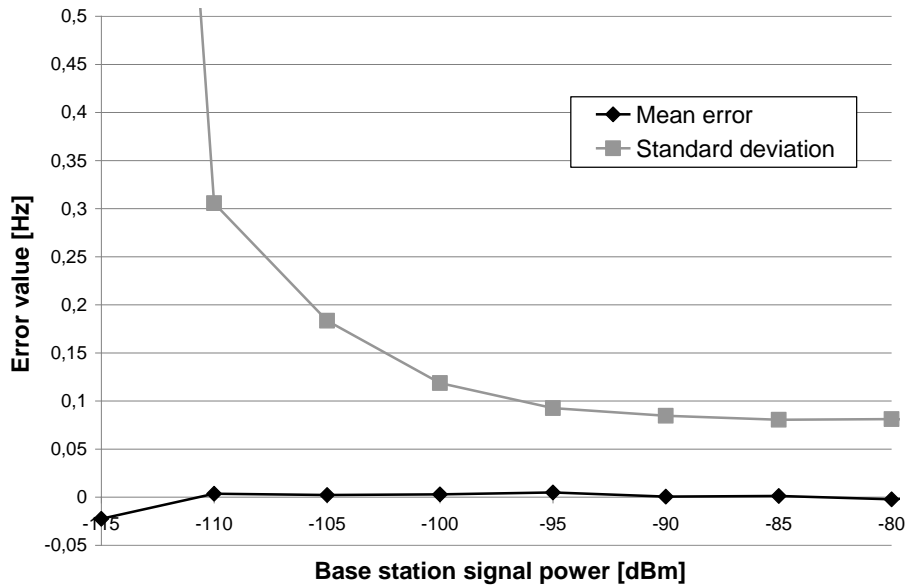

Fig. 8. Mean error and standard deviation of carrier frequency measurement as function of received base station signal power.

For received signal power greater than -95dBm and equal for all base stations, the accuracy of carrier frequency measurement does not depend on signal power. In that case the main source of errors is the signal to interference ratio, because only one DS-CDMA signal (PLD/ELD) is useful during frequency measurement and all remaining signals (from the other two base stations in this example) are interference signals. Fig. 9 presents frequency measurement errors as a function of the ratio between measured base station signal level and the level of two other interfering signals, while the interference level was set to a fixed value -70dBm at the input of the receiver. Please note that the ratio between the measured signal and the total level of interference is 3dB lower due to two interfering signals with equal power.

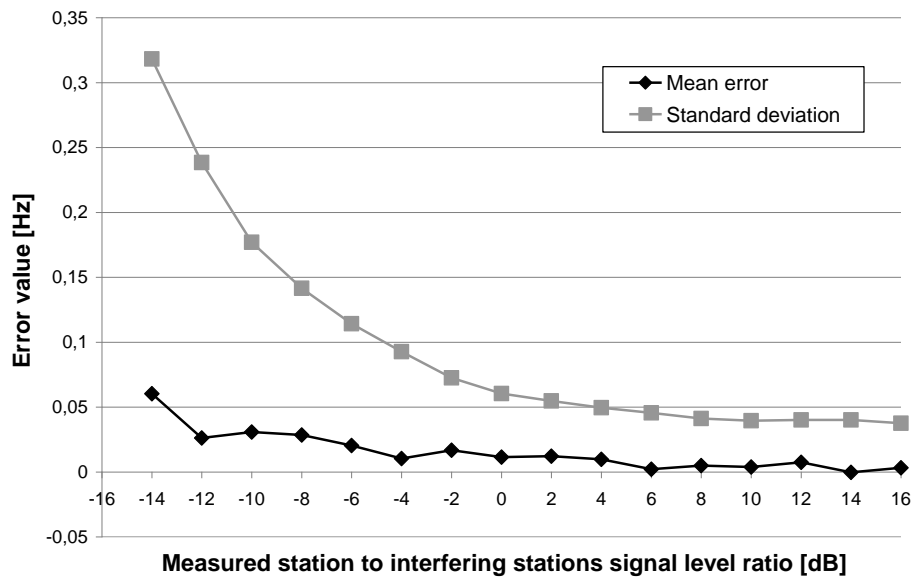

Fig. 9. Mean error and standard deviation of carrier frequency measurement as a function of measured station to interfering stations power ratio.

6. FDOA velocity measurement

The evaluation of carrier frequency estimation errors, described in Chapter 5, cannot present all of the properties of the FDOA velocity measurement method. To take into account the impact of base stations and receiver positions geometry together with the impact of receiver local oscillator instability, a compound signal of three base stations with time and frequency relations corresponding to real conditions in the area of the Gulf of Gdansk was generated in the laboratory using the measurement set presented in Fig. 6. In that case the precision of measurements was estimated on the basis of velocity components v_x and v_y , not on the observed carrier frequencies.

The immunity of FDOA velocity measurement to receiver local oscillator frequency error was tested using signals corresponding to reception point no. 1 (Fig. 10), which was close to the centre of the area bounded by base stations (best accuracy of position measurements using the TDOA method). The Doppler frequency shift for all base stations was chosen to emulate the movement of a receiver with velocity components $v_x=8\text{m/s}$ and $v_y=4\text{m/s}$ while the receiver was clocked by an external reference signal with controlled frequency error from 0 to 1×10^{-7} . Results of error measurements (in X and Y axis separately) made with a receiver clocked by an external reference signal with a different frequency error are presented in Fig. 11 (data marked as “ext. clock”). This chart includes also results of velocity measurement error analysis for receiver clocked by an internal oscillator (data marked as “int. clock”).

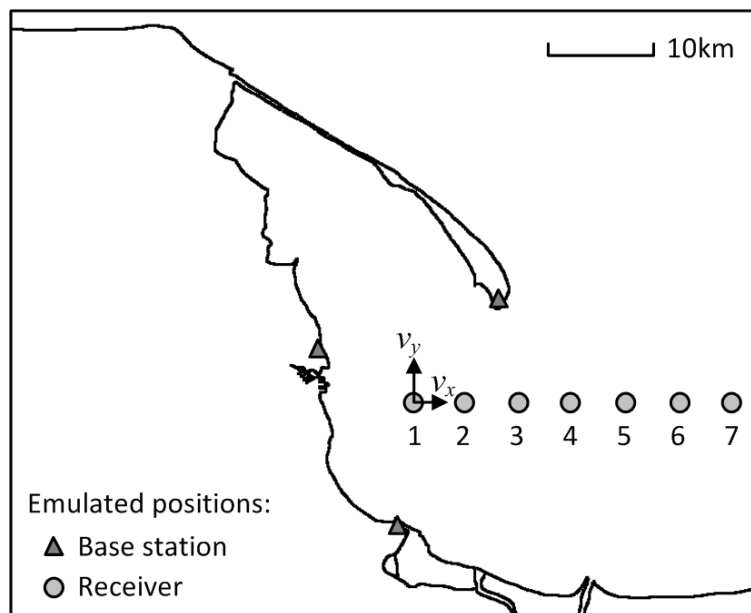

Fig. 10. Map of Gulf of Gdansk with positions of base stations and measurement points emulated in the laboratory.

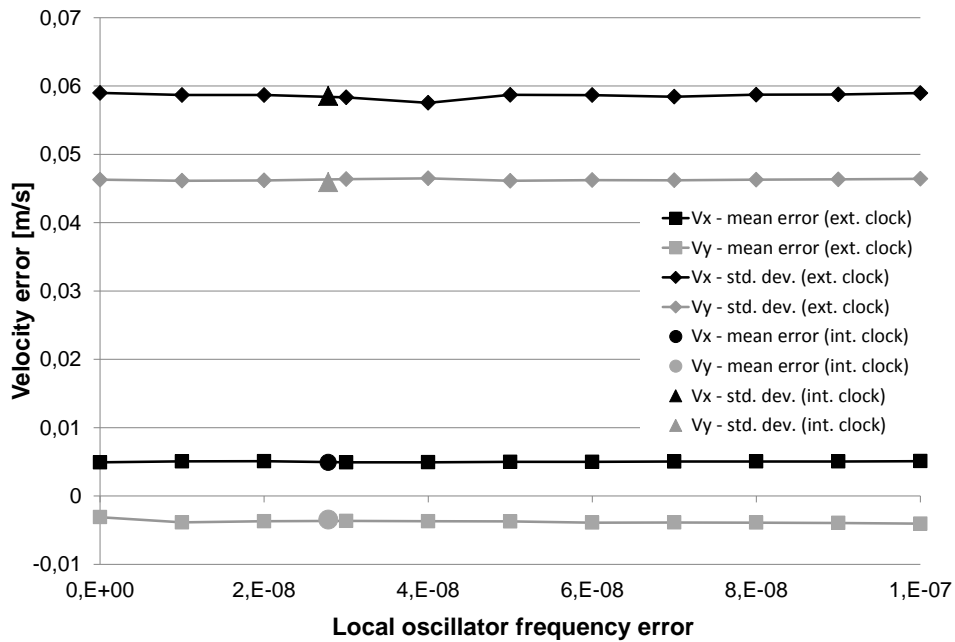

Fig. 11. Velocity measurement error analysis (mean errors and standard deviations) as a function of receiver local oscillator frequency error (internal and external clock source).

From the chart presented in Fig. 11, two conclusions can be drawn:

- the accuracy and precision of proposed implementation of FDOA velocity measurement does not depend on receiver local oscillator frequency shift,
- the stability of EM550 receiver internal reference oscillator is sufficient for FDOA measurements (error values for measurements with internal and external reference oscillator are similar).

The geometry of velocity vector components, presented in Fig. 4, suggests that propagation of carrier frequencies Doppler shift measurement errors into velocity errors depends on the values of angles between the axis joining the navigation receiver and base stations. In that case the precision of velocity measurements will degrade as the receiver moves away from the centre of the area covered by the navigation service. The degradation of velocity measurement performance caused by geometrical relationships in radio navigation system was measured by emulation of seven different positions of the navigation receiver, arranged in a straight line, as presented in Fig. 10. The distance between emulated adjacent measurement points was equal to 5km. Mean error values and standard deviation of errors of velocity components v_x and v_y are plotted in Fig. 12.

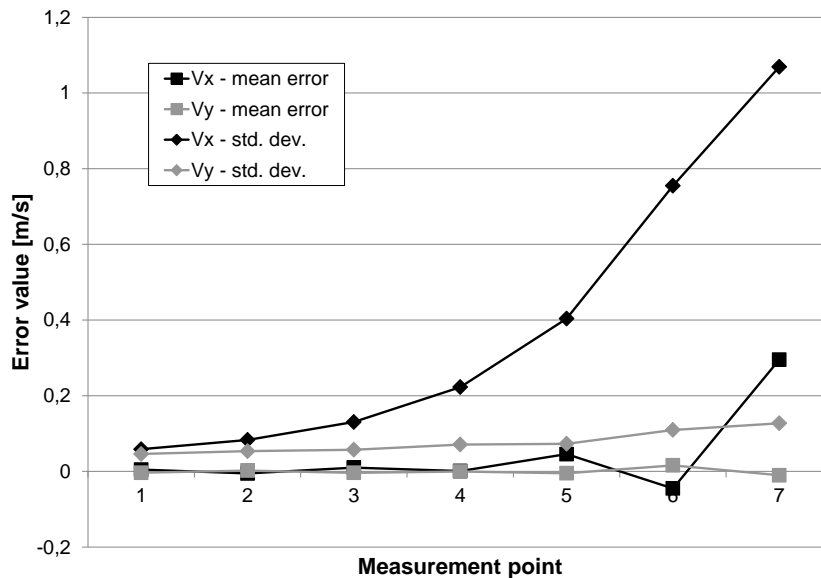

Fig. 12. FDOA velocity measurement error analysis for a receiver moving away from the centre of the area covered by the navigation service.

Measurements proved that accuracy and precision of velocity estimation is position-dependent, but for measurement points distant from the centre of the area covered by the navigation service the degradation of performance is not the same for velocity components v_x and v_y . In that example v_x can be named “radial” velocity component in the axis to-from the centre of good geometry, while v_y is the “circular” component ($\sigma_{v_x}=1.06$ m/s, $\sigma_{v_y}=0.12$ m/s in position “7”). Measurements in other positions of the receiver (30 km north of the point marked “1” in Fig. 10) proved that the performance of velocity estimation using the FDOA method is worse for the “radial” component than for “circular” component ($\sigma_{v_x}=0.08$ m/s, $\sigma_{v_y}=1.04$ m/s in that position).

7. Conclusions

The proposed implementation of velocity estimation in a ground-based radio navigation system provides fast measurement using simple transformation of data already available in a DS-CDMA correlation receiver. This allows to add the velocity estimation feature even to asynchronous radio navigation systems (such as AEGIR), without any changes in the physical layer – only some new information about base station carrier frequency differences needs to be transmitted from reference stations to navigation receivers using a data communication channel. Therefore in most implementations the hardware in base stations and receivers may remain unchanged, only software update will be necessary.

Performance of the FDOA velocity measurement method in a DS-CDMA based radio navigation system can be further improved at least in two ways:

- by reduction of crosstalk caused by non-zero cross correlation function of pseudo-random sequences used in base stations, using multiuser detection algorithms [9–10],
- by additional filtering of position/velocity data which fits ship dynamics of motion, because most ships (vehicles) cannot change their velocity in a time of milliseconds.

References

- [1] Ambroziak, S., Katulski, R., Sadowski, J., Siwicki, W., Stefanski, J. (2012). AEGIR – Asynchronous Radiolocation System. In *Proc. of The Eight International Conference on Wireless and Mobile Communications*. Venice, Italy, 103–109.
- [2] Ambroziak, S., Katulski, R., Sadowski, J., Siwicki, W., Stefanski, J. (2012). Ground-based radiolocation system – AEGIR. In *Proc. 8th International Symposium on Mechatronics and its Applications*. Sharjah, UAE, 1–5.
- [3] Katulski, R., Stefanski, J., Siwicki, W., Sadowski, J., Ambroziak, S. (2011). *Asynchronous system and method for estimating position of persons and/or objects*. European patent application no. 11460023.
- [4] Stefanski, J. (2012). *Radio link measurement methodology for location service applications*. *Metrology and Measurement Systems*, 19(2), 333–342.
- [5] Berger, F.B. (1957). The Nature of Doppler Velocity Measurement, *IRE Trans. on Aeronautical and Navigational Electronics*, Vol. ANE-4, Iss. 3, 103–112.
- [6] Nicoloso, S. (1997). An investigation of carrier recovery techniques for PSK modulated signals in CDMA and multipath mobile environments, MSc thesis, The Bradley Department of Electrical Engineering.
- [7] Rutman, J., Walls, F.L. (1991). Characterization of Frequency Stability in Precision Frequency Sources, *Proceedings of the IEEE*, Vol. 79, No. 6, 952–960.
- [8] Barnes, J. et al, (1971). Characterization of frequency stability, *IEEE Transactions on Instrumentation and Measurement*, Vol. IM-20, Iss. 2, 105–120.
- [9] Verdu, S. (2003). *Multiuser Detection*, Cambridge University Press.
- [10] Honig, M. (2009). *Advances in Multiuser Detection*, John Wiley & Sons.