

archives

of thermodynamics

Vol. 31(2010), No. 3, 55–72

DOI: 10.2478/v10173-010-0014-9

A new method for determining allowable medium temperature during transient operation of thick-walled elements in a supercritical power plant

PIOTR DUDA*
DARIUSZ RZĄSA

Cracow University of Technology, Department of Thermal Power Engineering,
al. Jana Pawła II 37, 31-864 Kraków, Poland

Abstract Construction elements of supercritical power plants are subjected to high working pressures and high temperatures while operating. Under these conditions high stresses in the construction are created. In order to operate safely, it is important to monitor stresses, especially during start-up and shut-down processes. The maximum stresses in the construction elements should not exceed the allowable stress limit. The goal is to find optimum operating parameters that can assure safe heating and cooling processes [1–5]. The optimum parameters should guarantee that the allowable stresses are not exceeded and the entire process is conducted in the shortest time. In this work new numerical method for determining optimum working parameters is presented. Based on these parameters heating operations were conducted. Stresses were monitored during the entire processes. The results obtained were compared with the German boiler regulations – Technische Regeln für Dampfkessel 301.

Keywords: Steam boilers; Total stresses; Heat transfer; Optimization

Nomenclature

$\mathbf{H}, \mathbf{J}, \delta$	–	matrices
\mathbf{x}	–	vector of searched parameters
k	–	thermal conductivity, W/(m K)
p_w	–	working pressure of medium, MPa

*Corresponding author. E-mail address: pduda@mech.pk.edu.pl

R_e	–	yield strength, MPa
S	–	sum of squares
t	–	time, s
T_{f0}	–	initial temperature of medium, °C
T_w	–	working temperature of steam, °C
v_T	–	rate of medium temperature change, K/min

Greek symbols

ε	–	convergence criterion
σ_a	–	allowable stresses, MPa
$\sigma_x, \sigma_y, \sigma_z$	–	total stresses in respective direction, MPa

1 Introduction

During start-up and shut-down operations high stresses in the power unit construction elements are created. These stresses are caused by internal pressure and temperature gradient in the wall of components that changes during heating and cooling operations. Therefore, it is important to conduct these operations in such way that the total stresses remain within the permissible stress limit, specified by boiler regulations.

German boiler regulations – Technische Regeln für Dampfkessel 301 (TRD 301) [6] – control the operation of steam boilers. According to these regulations medium temperature change rates v_{T_1} , v_{T_2} and allowable stresses σ_a are calculated. TRD 301 regulations assume quasi-steady one dimensional temperature distribution in the entire component. However, the quasi-steady state does not occur, especially, that the heating and cooling operations are transient processes. Thus, the operations conducted with parameters estimated according to TRD 301 may cause stresses that exceed stress limit σ_a .

Paper [3] presents the two-stage numerical method for determining optimum medium temperature transients, which ensures that the thermal stresses in the whole construction element does not exceed the allowable value. Firstly, change rate of medium temperature, based on the golden search method, is calculated. Next, the initial temperature step, utilizing the Levenberg-Marquardt formula is found. Paper [4] presents numerical optimization procedure, based on the Levenberg-Marquardt algorithm that allows to find the change rate of medium temperature and initial temperature step, simultaneously. This procedure is based on the assumption that the thermal stresses in the entire construction elements do not exceed the allowable stresses. This work presents a new numerical method for deter-

mining optimum medium temperature transients, based on the assumption that the total stresses in the power block devices are kept within the stress limit. Implementation of the proposed method is presented for heating operations of outlet header and separator. These construction elements are mounted in supercritical power plants.

Outlet header is mounted in the power unit of 460 MW and is designed for pressure $p_w = 29$ MPa and steam temperature $T_w = 559$ °C. The simplified model is presented in Fig. 1. Next element analyzed is separator, which works with steam pressure $p_w = 29.8$ MPa and steam temperature $T_w = 465$ °C. The geometry with basic dimensions is illustrated in Fig. 2.

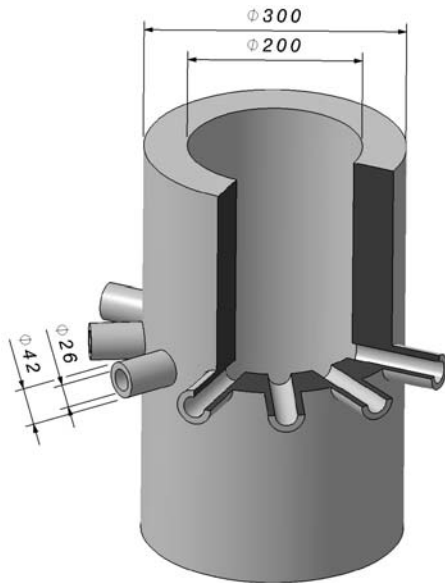

Figure 1. Geometry of outlet header in mm.

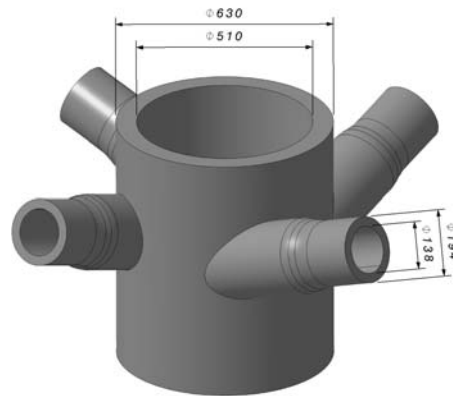

Figure 2. Geometry of separator in mm.

The elements presented are thick-walled elements made of ferritic alloy steel X10CrMoVNb9-1 (P91). The steel P91 is commonly used in the construction of supercritical power plants. It retains desirable material properties while operating with high temperatures and pressures. Selected thermal and mechanical properties [7] are presented in Figs. 3 and 4.

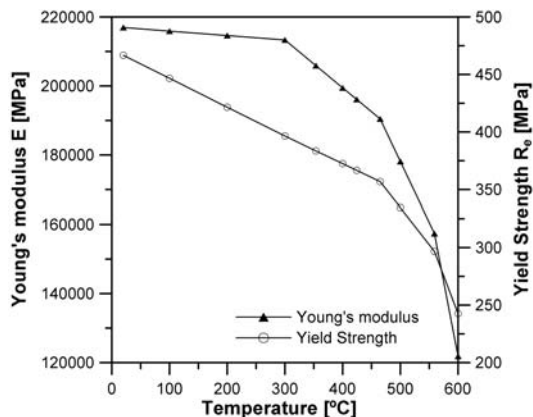

Figure 3. Mechanical properties of X10CrMoVNb9-1 (P91) steel.

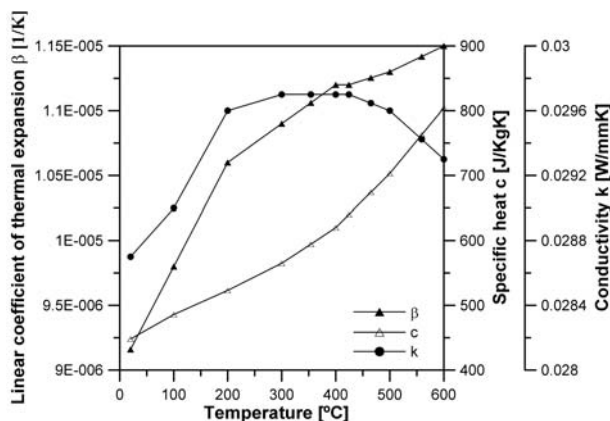

Figure 4. Thermal properties of X10CrMoVNb9-1 (P91) steel.

2 Formulation of the method

During the start-up process high stresses in the construction elements are created. Thus, it is recommended to find parameters that can maintain maximum stresses within the stress limit, whereas the heating time is shortest. These parameters were found based on the Levenberg-Marquardt (L-M) algorithm [8,9]. For optimization purpose of outlet header four optimum parameters T_{f_1} , v_{T_1} and T_{f_2} , v_{T_2} were found. Parameters v_{T_1} , v_{T_2} denote optimum rates of temperature change and T_{f_1} , T_{f_2} optimum fluid temperature steps. These parameters are found when the following equation is satisfied:

$$\sigma_a - \sigma_{\max}(T_{f_1}, v_{T_1}, T_{f_2}, v_{T_2}, t_i) \cong 0, \quad i = 1, \dots, m, \quad (1)$$

where σ_{\max} denotes the highest value of total stresses in the whole construction element, m denotes the number of time points during the heating process. Again, minimizing the sum

$$S(x) = \sum_{i=1}^m [\sigma_a - \sigma_{\max}(T_{f_1}, v_{T_1}, T_{f_2}, v_{T_2}, t_i)]^2 \cong 0, \quad i = 1, \dots, m, \quad (2)$$

allows to establish the optimum parameters.

In the optimization procedure of heating process of separator only two parameters were found. Therefore, Eq. (2) reduces to the following form

$$S(x) = \sum_{i=1}^m [\sigma_a - \sigma_{\max}(T_{f_1}, v_{T_1}, t_i)]^2 \cong 0, \quad i = 1, \dots, m. \quad (3)$$

The parameters are updated at every k -th iteration step based on the following rule

$$\mathbf{x}^{(k+1)} = \mathbf{x}^{(k)} + \boldsymbol{\delta}^{(k)}. \quad (4)$$

The searched parameters of \mathbf{x} are denoted as $x_1 = T_{f_1}$, $x_2 = v_{T_1}$, $x_3 = T_{f_2}$, $x_4 = v_{T_2}$ for outlet header and $x_1 = T_{f_1}$, $x_2 = v_{T_1}$ for separator, whereas

$$\boldsymbol{\delta}^{(k)} = \left(\mathbf{H}^{(k)} + \lambda \text{diag} \mathbf{H}^{(k)} \right)^{-1} \left(\mathbf{J}^{(k)} \right)^T \left[\sigma_a - \sigma_{\max} \left(x^{(k)} \right) \right], \quad k = 0, 1, \dots. \quad (5)$$

The \mathbf{H} and \mathbf{J} denote Hessian and Jacobian matrices, respectively. They are expressed as follows:

$$\mathbf{J}^{(k)} = \left. \frac{\partial \sigma_{\max}(x)}{\partial x^T} \right|_{x=x^{(k)}} = \left[\begin{array}{ccc} \frac{\partial \sigma_1}{\partial x_1} & \cdots & \frac{\partial \sigma_1}{\partial x_n} \\ \cdots & \cdots & \cdots \\ \cdots & \cdots & \cdots \\ \frac{\partial \sigma_m}{\partial x_1} & \cdots & \frac{\partial \sigma_m}{\partial x_n} \end{array} \right] \Bigg|_{x=x^{(k)}} \quad (6)$$

and

$$\mathbf{H}^{(k)} = \left. \frac{\partial^2 \sigma_{\max}(x)}{(\partial x^T)^2} \right|_{x=x^{(k)}} = \left[\begin{array}{ccc} \frac{\partial^2 \sigma_1}{\partial x_1 \partial x_1} & \cdots & \frac{\partial^2 \sigma_1}{\partial x_1 \partial x_n} \\ \cdots & \cdots & \cdots \\ \cdots & \cdots & \cdots \\ \frac{\partial^2 \sigma_m}{\partial x_n \partial x_1} & \cdots & \frac{\partial^2 \sigma_m}{\partial x_n \partial x_n} \end{array} \right] \Bigg|_{x=x^{(k)}}. \quad (7)$$

The optimum parameters are found if the assumed convergence criterion

$$x_i^{(k+1)} - x_i^{(k)} \leq \varepsilon, \quad i = 1, \dots, n \quad (8)$$

is fulfilled.

3 Outlet header

In this section the start-up operation of outlet header was carried out. This operation was conducted according to German boiler regulations – Technische Regeln für Dampfkessel 301 (TRD 301) and the proposed numerical method. For both cases the medium temperature was determined. In order to monitor stresses in the construction during heating process, numerical method based on finite element method (FEM) was used. The outlet header geometry was divided into eight-node finite elements. Since the element is symmetrical 1/2 was modeled and analyzed as shown in Fig. 5.

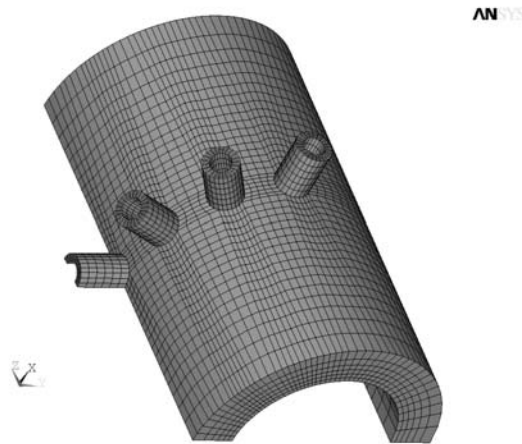

Figure 5. The outlet header divided into finite elements.

3.1 Technical rules for steam boilers — TRD 301

The German boiler regulations – Technische Regeln für Dampfkessel 301 (TRD 301) – control heating and cooling processes of power blocks. TRD procedure allows estimating the allowable rates of medium temperature change and allowable stresses during start-up and shut-down operations.

The allowable heating parameters calculated for the outlet header are: $v_{T_1} = 7.1$ K/min and $v_{T_2} = 18.85$ K/min. Parameters v_{T_1} and v_{T_2} denote the change rates of medium temperature at the beginning and at the end of process, respectively. The allowable compressive stresses during heating operation are $\sigma_a = -126.7$ MPa, tensile stresses $\sigma_a = 337$ MPa. Figure 6 shows temperature and pressure transients during the start-up process. For calculated temperature and pressure history thermal-strengths analysis was performed. The heating operation was conducted until working parameters $p_w = 29$ MPa and $T_w = 559$ °C were reached. During this phase high compressive stresses on the heated surface were observed. These stresses are caused by temperature gradient along the thickness of the wall and high internal pressure. The variation of stresses during that process is presented in Fig. 7.

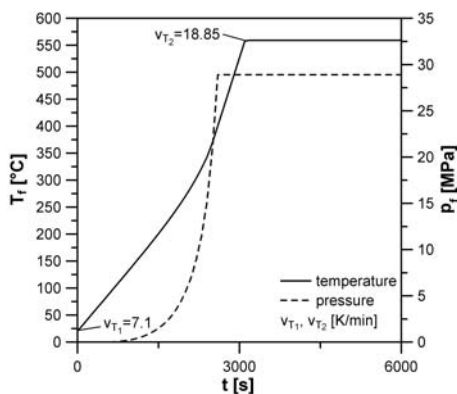

Figure 6. Temperature and pressure history during heating operation based on TRD 301 regulations.

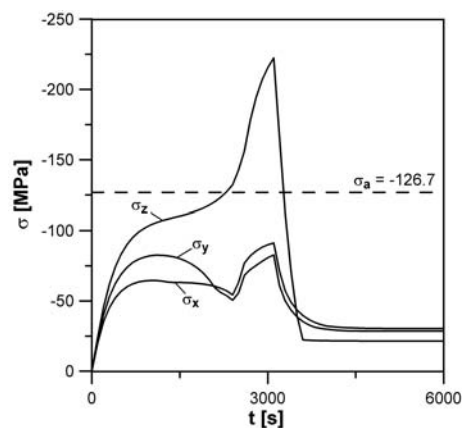

Figure 7. Maximum compressive stress history during start-up process according to TRD 301 regulations.

The maximum compressive stresses occurred at time $t = 3100$ s and reached value above -222 MPa. It can be seen that the allowable stress $\sigma_a = -126.7$ MPa was exceeded. Figures 8 and 9 show maximum compressive and tensile stress areas during start-up process.

The maximum compressive stresses were found on the inner surface near the opening edges. The highest tensile stresses were recorded on the outer surface and reached value of 182.6 MPa.

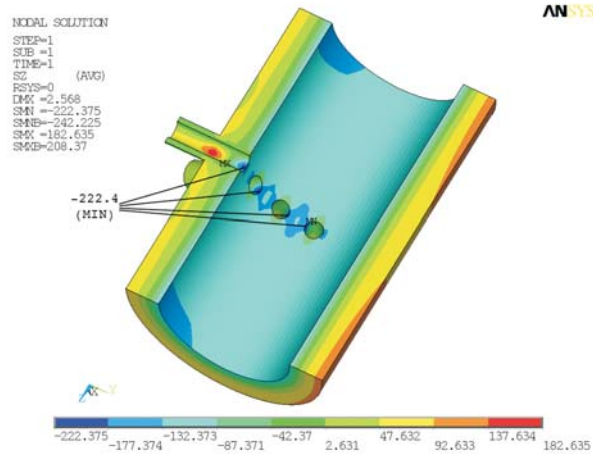

Figure 8. Maximum compressive stress σ_z distribution in MPa for $t = 3100$ s.

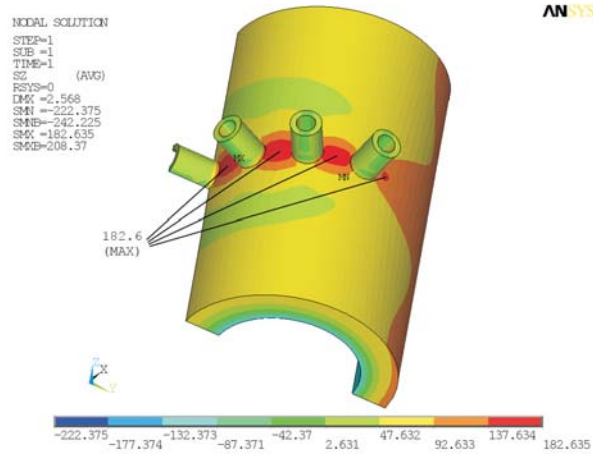

Figure 9. Maximum tensile stress σ_z distribution in MPa for $t = 3100$ s.

3.2 Optimization method

Numerical finite element analysis proved that heating operation of outlet header based on the German boiler regulations TRD 301 causes stresses in the construction that exceed the allowable stress $\sigma_a = -126.7$ MPa (Fig. 7). Thus, it is important to find the start-up parameters that can keep maximum stresses in the outlet header within stress limits and the entire operation is conducted in the shortest time. This paper presents a new developed numerical method that is used to optimize heating operation based on total stress limitation. Using the proposed method the four start-up parameters $T_{f_1}, v_{T_1}, T_{f_2}, v_{T_2}$ were found, where T_{f_1}, T_{f_2} are step changes of temperature and v_{T_1}, v_{T_2} denote the temperature change rates.

Consider the heating process where only two start-up parameters T_{f_1}, v_{T_1} are known. The outlet header has a uniform temperature $T_0 = 20$ °C. Next, hot fluid enters the inner space of the component with initial temperature $T_{f_1} = 66$ °C. Subsequently, temperature of fluid changes with constant rate of temperature change $v_{T_1} = 8.2$ K/min. Working medium pressure p_f is assumed to be a function of temperature until time t_1 , where the working pressure $p_w = 29$ MPa is reached (Fig. 10).

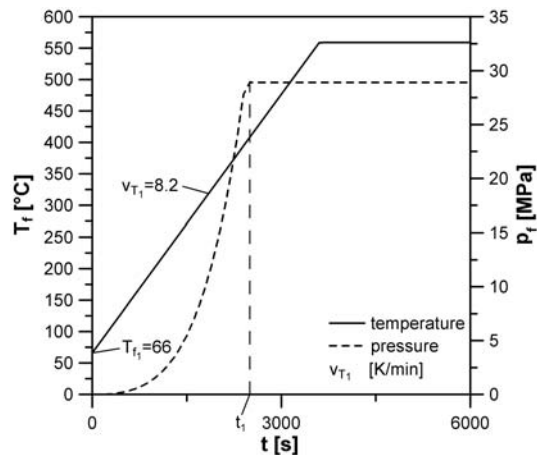

Figure 10. Temperature and pressure history for two optimum parameters.

Stress analysis conducted for presented in Fig. 10 temperature and pressure history proved that during heating operation high compressive stresses are created. These stresses decrease with increasing pressure as shown in Fig. 11.

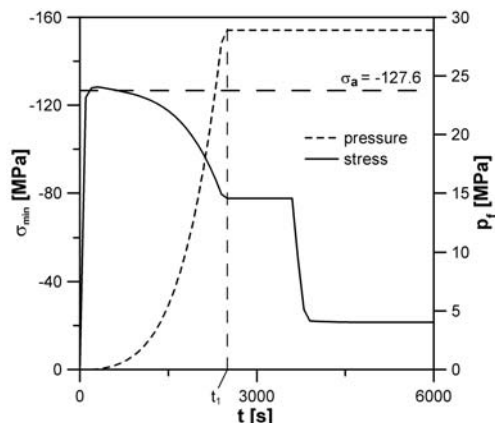

Figure 11. Maximum compressive stress history during heating operation based on two optimum parameters.

Since the maximum compressive stresses are below the allowable stress $\sigma_a = -126.7$ MPa, heating process can be conducted with higher rates of temperature change. Thus, two additional parameters $T_{f_2} = 444$ °C, and $v_{T_2} = 11.4$ K/min were introduced, where T_{f_2} is the second step change of temperature and v_{T_2} denotes the second rate of temperature change. The introduction of these parameters is possible after time t_1 , where the working medium pressure does not depend on the temperature. The temperature and pressure history for four optimum parameters is presented in Fig. 12.

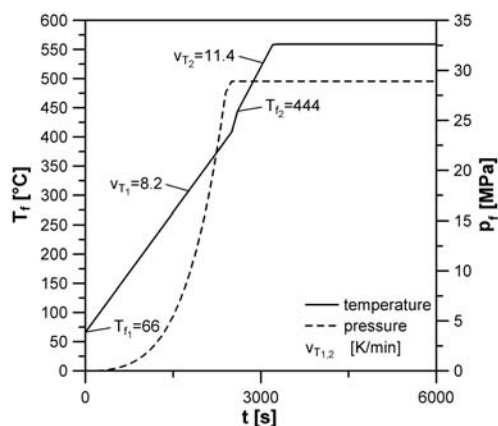

Figure 12. Temperature and pressure history for four optimum parameters.

Figure 13 presents maximum compressive stress variations that were recorded during start-up process conducted with four optimum parameters. The highest compressive stresses were observed at time $t = 2800$ s at the opening edges on the inner surface as plotted in Fig. 14. Figure 15 shows maximum tensile stress areas located on the outer surface with the highest value of 149.5 MPa.

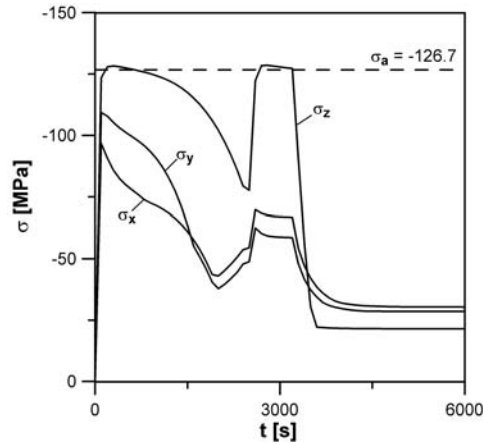

Figure 13. Maximum compressive stress history during start-up process according to optimization method.

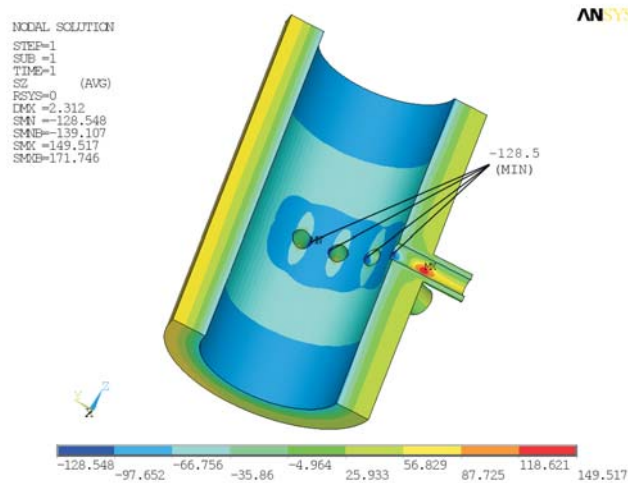

Figure 14. Maximum compressive stress σ_z distribution on the inner surface in MPa for $t = 2800$ s.

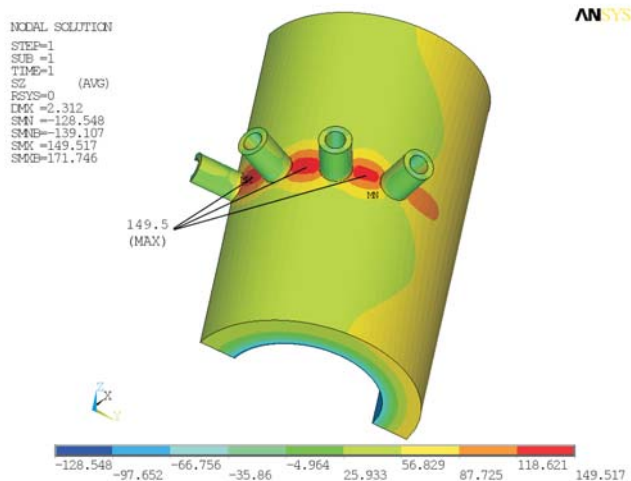

Figure 15. Maximum tensile stress σ_z distribution on the outer surface in MPa for $t = 2800$ s.

Stress variation during heating process based on TRD regulations and optimization method is illustrated in Fig. 16.

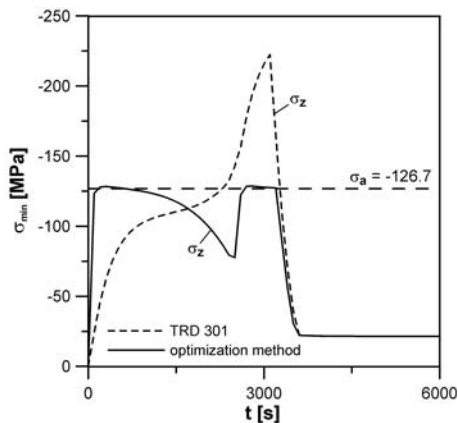

Figure 16. Maximum compressive stress history during heating process based on optimization method in comparison with TRD 301 regulations.

4 Separator

This section presents the start-up operation of separator. The operation was conducted according to German boiler regulations – Technische Regeln für Dampfkessel 301 (TRD 301) and the proposed numerical method. For subsequent analysis the allowable medium temperature was determined. Stresses in the construction during heating process were monitored with the use of numerical analysis based on finite element method (FEM). The separator geometry was divided into eight-node finite elements. Since the element is symmetrical 1/4 was modeled and analyzed as shown in Fig. 17.

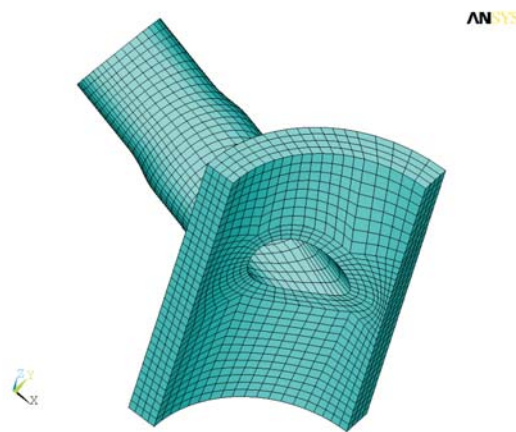

Figure 17. Separator divided into finite elements.

The allowable heating parameters $v_{T_1} = 5.6$ K/min and $v_{T_2} = 23.8$ K/min for separator were calculated based on the German boiler regulations (TRD 301). Parameters v_{T_1} and v_{T_2} denote the change rates of medium temperature at the beginning and at the end of process, respectively. The allowable stresses during the heating operation are $\sigma_a = -126.2$ MPa. Figure 18 shows temperature and pressure transients during the start-up process.

For presented temperature and pressure history the thermal-strengths analysis was performed. The heating operation was carried out until operation parameters $p_w = 29.8$ MPa and $T_w = 465$ °C were reached. During this phase high compressive stresses caused by temperature gradient along the thickness of the wall and high internal pressure were observed. The variation of stresses during that process is presented in Fig. 19.

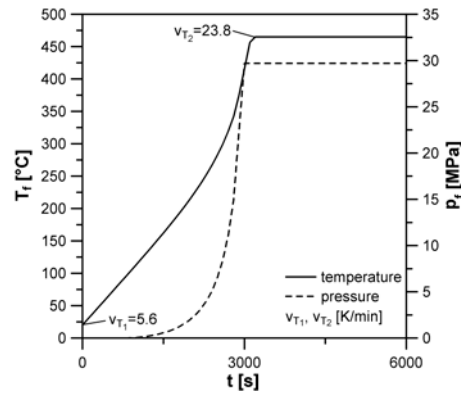

Figure 18. Temperature and pressure history during heating operation based on TRD 301 regulations.

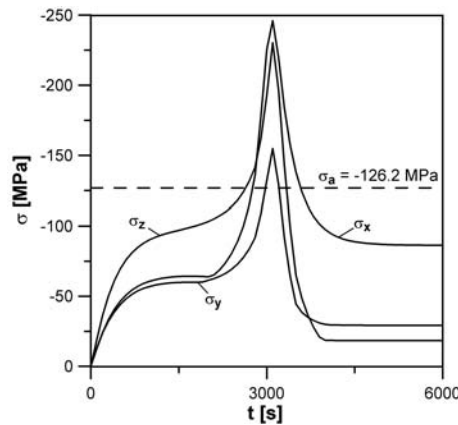

Figure 19. Maximum compressive stress history during start-up process according to TRD 301 regulations.

The maximum compressive stresses occurred at time $t = 3100$ s and reached value above -246 MPa. It can be noticed that allowable stress $\sigma_a = -126.2$ MPa was exceeded. The maximum compressive stress areas are presented in Fig. 20.

They were found on the inner surface near the opening edges. The highest tensile stresses were recorded on the outer surface and reached value of 312.3 MPa.

Previous finite element analysis proved that heating operation of separator based on the German boiler regulations TRD 301 causes stresses in the

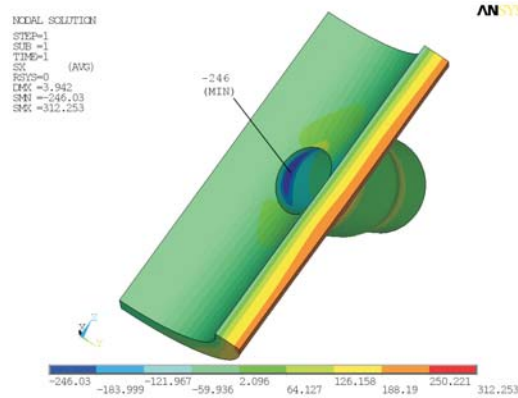

Figure 20. Maximum compressive stress σ_x distribution in MPa for $t = 3100$ s.

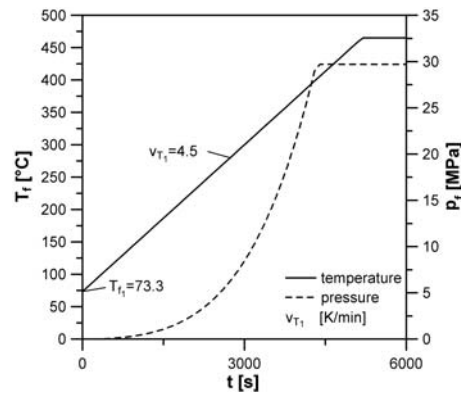

Figure 21. Temperature and pressure history for two optimum parameters.

construction that exceed the stress limit $\sigma_a = -126.2$ MPa (Fig. 19). Therefore, optimum start-up parameters are searched, that can reduce maximum stresses in the separator to the allowable stresses and decrease operation time to minimum. For separator two optimum start-up parameters T_{f1} , v_{T1} were found. Here T_{f1} is step change of temperature and v_{T1} denotes temperature change rate.

The separator has a uniform temperature $T_0 = 20$ °C. Next, hot working medium enters the inner space of the construction element with initial temperature $T_{f1} = 73.3$ °C. Subsequently, temperature of fluid changes with constant rate of temperature change $v_{T1} = 4.5$ K/min. Working medium pressure p_f is assumed to be a function of temperature (Fig. 21). The op-

eration is performed until nominal working parameters are reached. Compressive stress variation for presented in Fig. 21 temperature and pressure history is shown in Fig. 22.

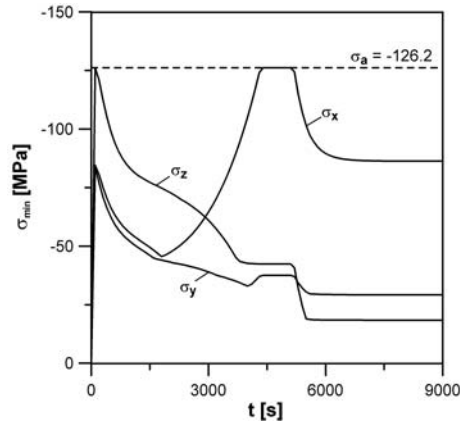

Figure 22. Maximum compressive stress history during start-up process according to optimization method.

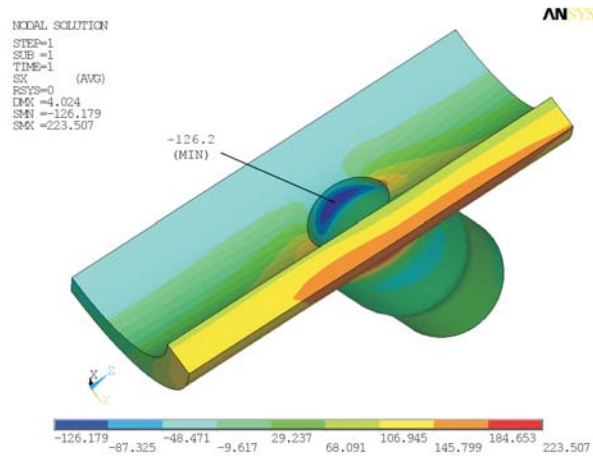

Figure 23. Maximum compressive stress σ_x distribution on the inner surface in MPa for $t = 4400$ s.

The highest compressive stresses were observed at time $t = 4400$ s at the opening edges on the inner surface as plotted in Fig. 23. Maximum tensile stress areas occurred on the inner surface with the highest value of

351.4 MPa. Stress variation during heating process based on TRD regulations and optimization method is illustrated in Fig. 24.

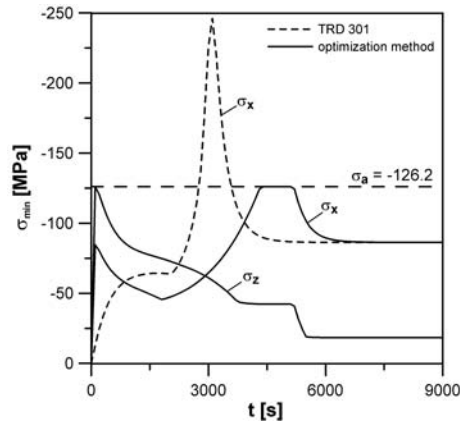

Figure 24. Maximum compressive stress history during heating process based on optimization method in comparison with TRD 301 regulations.

5 Conclusions

The start-up operations of outlet header and separator were presented. During these operations stresses in the construction elements were monitored. It was proved that during heating operation, conducted according to german boiler regulations TRD 301, high compressive stresses were formed. These stresses exceeded the allowable stress σ_a . Next, the new numerical method based on the Levenberg-Marquardt algorithm was presented. Using this method optimum start-up parameters were found. Heating operations conducted with optimum parameters showed that the maximum stresses in the components were limited to allowable stresses.

Operating steam boilers with optimum working parameters does not diminish the lifespan of components and reduces the start-up and shut-down losses. The new proposed method can be also implemented in the optimization of heating and cooling processes of conventional power unit devices.

Acknowledgement Part of this work was done within the confines of cooperation between TÜV NORD EnSys Hannover GmbH & Co. KG and Cracow University of Technology.

Received 15 June 2010

References

- [1] TALER J., DUDA P.: *Solving Direct and Inverse Heat Conduction Problems*. Springer-Verlag, Berlin Heidelberg 2006.
- [2] TALER J., DZIERWA P.: *A new method for determining allowable medium temperature during heating and cooling of thick walled boiler components*. Proceedings of the Congress on Thermal Stresses, Taipei 2007.
- [3] DUDA P., DWORNICKA R.: *Optimization of heating and cooling operations of steam gate valve*. Struct Multidisc Optim **40** (2010), 529–535.
- [4] DUDA P., RZASA D.: *Optimization of steam gate valve heating operation using Levenberg-Marquardt method*. Proc. of the 8th Int. Congress on Thermal Stresses, Vol. 2, Urbana – Champaign 2009, 399–402.
- [5] TALER J., WĘGŁOWSKI B., GRĄDZIEL S., DUDA P., ZIMA W.: *Monitoring of thermal Stresses in pressure components of large Steam Boilers*. VGB KraftwerksTechnik **1**, 2002.
- [6] TRD 301, *Technische Regeln für Dampfkessel*. Carl Heymans Verlag, Köln und Beuth-Verlag, Berlin 1986, 98–138.
- [7] RICHTER F.: *Physikalische Eigenschaften von Stählen und ihre Temperaturabhängigkeit*. Mannesmann Forschungberichte 930, Düsseldorf 1983.
- [8] SEBER GAF., WILD CJ.: *Nonlinear Regression*. John Wiley & Sons, New York 1989.
- [9] PRESS W.H., TEUKOLSKY SA, VETTERLING WT, FLANNERY BP.: *Numerical Recipes, The Art of Scientific Computing*. Cambridge University Press, 1997.