

Membrane separation of carbon dioxide in the integrated gasification combined cycle systems

JANUSZ KOTOWICZ
ANNA SKOREK-OSIKOWSKA*
KATARZYNA JANUSZ-SZYMAŃSKA

Silesian University of Technology, Institute of Power Engineering and Turbomachinery, Faculty of Energy and Environmental Engineering, Konarskiego 18, 44-100 Gliwice, Poland

Abstract Integrated gasification combined cycle systems (IGCC) are becoming more popular because of the characteristics, by which they are characterized, including low pollutants emissions, relatively high efficiency of electricity production and the ability to integrate the installation of carbon capture and storage (CCS). Currently, the most frequently used CO₂ capture technology in IGCC systems is based on the absorption process. This method causes a significant increase of the internal load and decreases the efficiency of the entire system. It is therefore necessary to look for new methods of carbon dioxide capture. The authors of the present paper propose the use of membrane separation. The paper reviews available membranes for use in IGCC systems, indicates, inter alia, possible places of their implementation in the system and the required operation parameters. Attention is drawn to the most important parameters of membranes (among other selectivity and permeability) influencing the cost and performance of the whole installation. Numerical model of a membrane was used, among others, to analyze the influence of the basic parameters of the selected membranes on the purity and recovery ratio of the obtained permeate, as well as to determine the energetic cost of the use of membranes for the CO₂ separation in IGCC systems. The calculations were made within the environment of the commercial package Aspen Plus. For the calculations both, membranes selective for carbon dioxide and membranes selective for hydrogen were used. Properly selected pressure before and after membrane module allowed for minimization of energy input on CCS installation assuring high purity and recovery ratio of separated gas.

*Corresponding author. E-mail address: Anna.Skorek@polsl.pl

Keywords: IGCC; CCS; Membrane separation

Nomenclature

A_m	–	membrane surface area, m ²
J_i	–	permeate stream, kmol/s
n	–	molar stream, kmol/s
N_{el}	–	electrical power, MW
p	–	pressure, bar, MPa
P_i	–	permeability of i -th component, m ³ (STP)/(m · h · bar), Barrer
X_i, Y_i	–	molar share of i -th component

Greek symbols

δ	–	membrane thickness, m
----------	---	-----------------------

Subscripts

C	–	compressors
F	–	feed
P	–	permeate
R	–	retentate
VP	–	vaccum pump

1 Introduction

Over 50% of all electricity in the EU comes from burning the fossil fuels, especially from burning coal and natural gas. Combustion of these fuels is accompanied by emissions of large amounts of pollutants into the atmosphere, including mainly CO₂, SO₂, NO_x and dust. Some of these pollutants, including carbon dioxide, methane, nitrous oxide and water vapor are considered to be so-called greenhouse gases, causing the greenhouse effect. In order to counteract the anthropogenic emissions to the atmosphere, EU member states have adopted, inter alia, climate package [20], which determines several objectives to achieve:

- reduce greenhouse gases emissions by 20% compared to the baseline year (1990),
- reduce energy consumption by 20% compared to the forecasts for the EU for the year 2020,
- increase the share of renewable sources to 20% of the total energy consumption in the EU.

These and other regulations (e.g. emissions trading scheme [21]) cause, that in the near future, electricity producers will be forced to further reduce the amount of emitted pollutants, including primarily carbon dioxide. For years, studies on such use of coal technologies, that would enable the reduction of emissions of sulfur oxides, nitrogen, carbon dioxide, heavy metals and other pollutants with simultaneous high efficiency of energy production have been conducted. These are the so-called Clean Coal Technologies. One such technology, which allows to reduce the emission of harmful compounds, is gasification of coal in the integrated gasification combined cycle systems (IGCC) integrated with the installation of carbon capture and storage (CCS). Integration of IGCC with CCS system may in future allow for economically viable adherence to severe standards on CO₂ emissions to the atmosphere.

In IGCC systems coal is usually gasified with the use of air or oxygen and water vapor. The resulting gas is composed mainly of carbon monoxide and hydrogen. Gas is purified from the particulate matter, sulfur compounds and other pollutants. At this stage it is also possible to remove carbon dioxide. Captured CO₂ is transported to the storage site and the purified gas is directed to the electricity production system.

Currently, the main objective of the ongoing research is the capture of carbon dioxide to provide a minimum of 90% CO₂ capture. At the same time such methods of CO₂ separation are searched, in which the increase of electricity production costs will not be higher than 10% compared to existing systems without CO₂ capture [5,7]. In IGCC systems, carbon dioxide is usually separated before combustion (so called pre-combustion methods), from purified synthesis gas. There are several methods of capturing CO₂ from IGCC systems, which include physical and chemical absorption, adsorption, as well as cryogenic and membrane separation. Technologies that reached full maturity yet are only the methods of physical and chemical absorption. However, increasing interest is directed towards the techniques of CO₂ membrane separation, which is caused by its many advantages [4].

The main purpose of the paper is to review the available membranes for the use in IGCC systems and the analysis of the influence of basic parameters of membrane on the purity and the degree of permeate recovery. The energy input associated with the membrane separation technique for capture of carbon dioxide is also determined.

2 Membrane separation of CO₂ in the IGCC systems

The main advantages of IGCC systems are primarily a relatively high efficiency of energy production (currently in the range of 35–42% without CO₂ capture, and 31.5–40% with CCS installation [8]), low pollutants emissions (the lowest from all available coal technologies [9]) and high fuel flexibility (the possibility of using fuels of different quality).

Technologies of carbon dioxide capture from gases have for long been known and used in the chemical industry (e.g. in the process of natural gas cleaning), but captured carbon dioxide is usually discharged into the atmosphere. In a few cases, captured CO₂ is injected, for example, into exploited oil fields in order to intensify the extraction recovery (EOR – Enhanced Oil Recovery). Exemplary diagram of the IGCC system integrated with the installation of carbon dioxide capture is shown in Fig.1. The diagram indicates particular components of such a system, including those that must be taken into account in order to carry out the process of CO₂ capturing, which is primarily the shift reactor (conversion of CO to CO₂), carbon dioxide separation installation and the installation for CO₂ compression. Shift process proceeds according to the reaction:

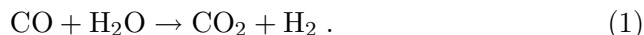

In the IGCC systems, carbon dioxide is captured before the combustion process – from synthesis gas, which consists mainly of carbon monoxide and hydrogen. To capture CO₂ from the synthesis gas different processes, which are based on chemical or physical absorption, adsorption, cryogenic or membrane separation may be used [10]. These processes are at different stages of technological development and the possibility of their implementation in the IGCC systems is different. Technologically mature are currently only processes based on physical and chemical absorption. Within chemical absorption processes the most frequently used absorbent is monoethanolamine (MEA), diethyloamine (DEA) and methyldiethanolamine (MDEA). Absorption processes require gas of high purity as well as large amounts of heat for separation of CO₂ from solvent. Due to high energy demand, processes based on cryogenic separation are not taken into account as a future for IGCC systems [10]. Whereas, attractive in terms of cost and energy demand appear to be processes of membrane separation of CO₂. Membrane gas separation techniques are known and used for many years in

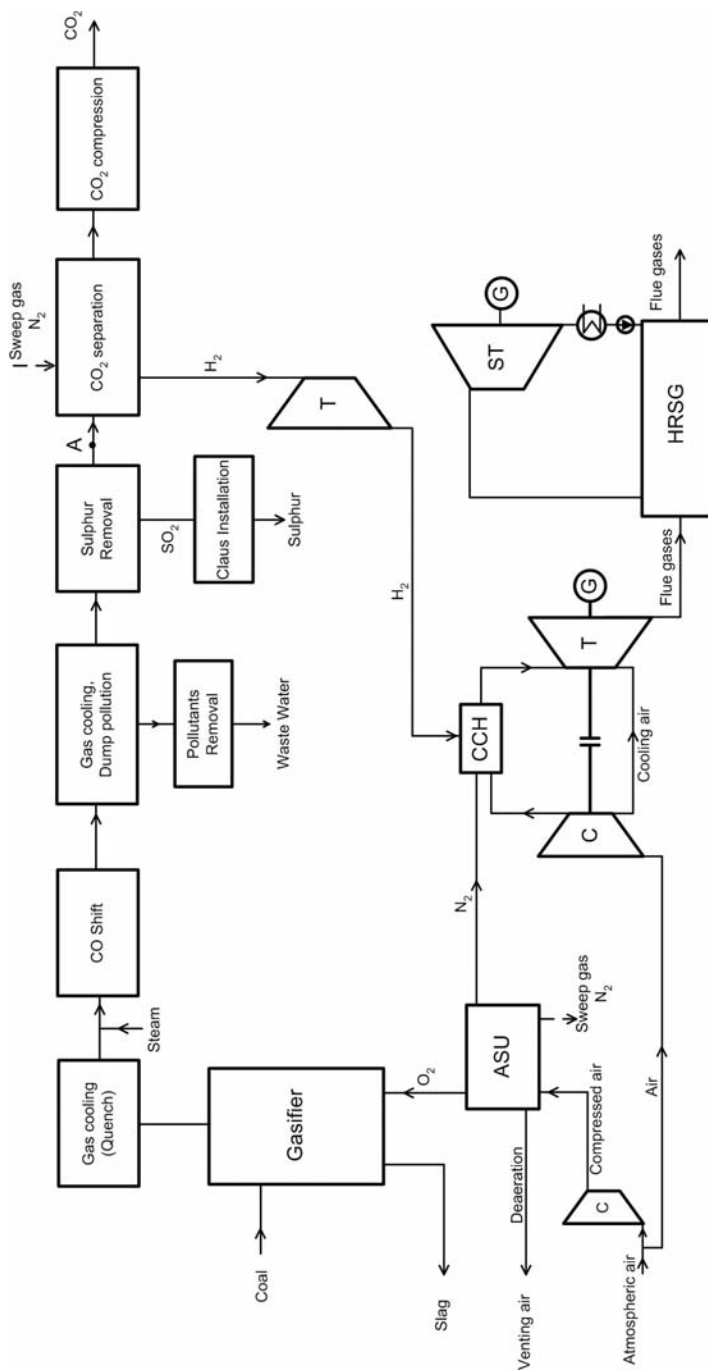

Figure 1. Scheme of the IGCC system integrated with carbon dioxide capture installation; Denotations: C – compressor, T – turbine, CCH – combustion chamber, HRSG – heat recovery steam generator, ASU – Air Separation Unit.

the petrochemical industry, but also for the purification of natural gas or for separation of oxygen from the air.

Membrane is a phase barrier that is used for separation of two different phases, allowing for the selective permeation of selected components. The stream supplied to the membrane module is divided to the permeate and the retentate stream. Permeate is the part of the feed stream, that penetrated through membrane, whereas the part of the stream that remained before the membrane is called the retentate. The most important parameters determining the effectiveness of the membrane separation process is its permeability and selectivity. Permeability defines the stream of the component of the mixture, which penetrated through the membrane, while the selectivity is defined as the ratio of permeability of the various components of the mixture through a membrane [12]. The scheme of the membrane is shown in Fig. 2.

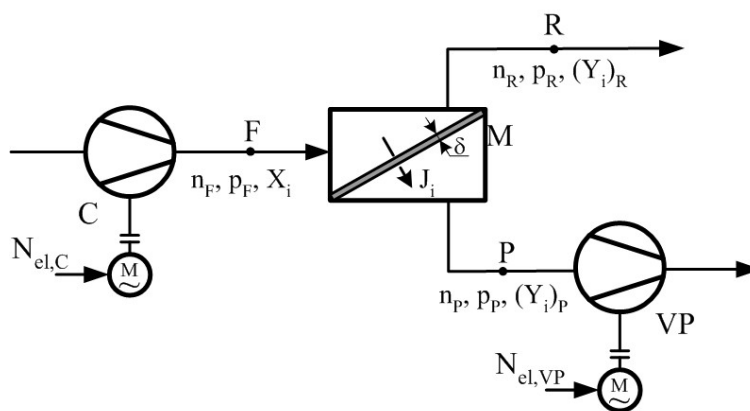

Figure 2. Permeation model through membrane (F – feed, P – permeate, R – retentate, M – membrane module, VP – vacuum pump, C – compressor).

Selectivity of membranes for gas separation depends primarily on the properties of the material from which they are made. In this respect synthetic and natural membranes can be distinguished, whereas when considering structure, porous membranes, non-porous and liquid can be enumerated [12,14]. Depending on the type of membrane different is the separation mechanism of individual components of the mixture. In the membrane separation technique differences between physical and chemical properties of particular components of the gaseous mixture and the separative membrane are used, which contributes to the permeation of gas through the membrane

material with different velocities. Flow through the separative membrane is forced by the partial pressure difference between the components on both sides of the membrane [14].

Membranes for gases separation are characterized by many advantages. One of them is that the substance remains in the gas phase (there is no phase change from the gas phase to the liquid). In addition, membrane installations are characterized by relatively small size (high package density of membranes), which may be relevant for the implementation of CO₂ capture systems for new and existing power plants. One disadvantage of membranes is that because of the possibility of membrane damage or deterioration of its properties they usually require prior deep purification of raw gas from dust, sulfur compounds and other pollutants. Due to the fact, that each process is characterized by a specific gas mixture composition, for its separation the appropriate type of membrane should be applied (e.g. for purification of natural gas – membranes separating CH₄ from the mixture of CH₄ and CO₂, described as CH₄/CO₂, for capturing of CO₂ after combustion process – N₂/CO₂ membrane). In the case of IGCC system synthesis gas is composed primarily of hydrogen and carbon monoxide (which, after the shift reaction turns into CO₂), thus membranes used in these systems are usually H₂/CO₂ membranes, although the separation can be carried out before the shift process, in that case a H₂/CO membranes should be applied [7].

The use of membranes in energy systems is possible thanks to the development of the separation technology and the creation of new composite membranes. In order to be able to use membranes in IGCC systems ensuring capturing of approximately 90% of the CO₂ selectivity of membranes must be above 30–40 [5]. For this purpose the most suitable are polymeric membranes, dense metallic membranes, ceramic and composite (ceramic-metallic). Because of its properties, currently the most widely used are polymeric membranes [7]. They are characterized by selectivity of usually less than 100. Their big advantage is the possibility to produce them in the form of hollow fibers of large surface area, what allows for a significant reduction of the size of the membrane and relatively low production cost [6]. The authors in [15] and [2] indicate the advantages of PBI membranes (polibenzimidazol) for carbon dioxide capturing before the combustion process, due to, inter alia, the opportunity to work at high temperatures (200–400 °C). Recently, special attention is paid to the palladium and hybrid membranes (a combination of ceramics with palladium or nickel), which are characterized by the work at very high temperatures (320–900 °C) [5], as well as the

selectivity coefficient above 1000. A big advantage of using of membranes is possibility to ensure a concentrated stream of CO₂ at high pressure (usually 40–55 bar), which reduces the amount of energy needed for the compression and further transportation [15].

Cost-effectiveness of membrane separation depends to a high degree on the properties of membranes, especially the degree of permeability and selectivity. The ideal membranes should be characterized by high values of both these parameters for the specific component of the gaseous mixture. For most of the membranes with higher permeability, the selectivity decreases and vice versa [14].

Membrane for gases separation may be placed in various locations of IGCC systems, depending on the nature of the membranes. It depends on many factors, including the properties of the membrane (if it is selective for hydrogen, carbon monoxide or carbon dioxide), membranes operation temperatures and tolerance on the presence of various components in the separated gas [5]. Due to the fact that the captured CO₂ must be compressed to about 15 MPa [15], it is beneficial to capture CO₂ under high pressure. Therefore, it is better to apply membranes selective to hydrogen. It is possible to use membrane resistant to high temperature – then the separation is at the so-called hot/dirty end, and subjected to separation gases are not completely cleaned, or to use separating membranes at lower temperatures – then separation is at the so-called cold/clean end [5]. Process parameters (temperature, pressure and gas composition) are different in different locations of the system and therefore the placement of the membrane will determine the conditions that must be met. Choosing the right location in the membrane is very important for the effective separation of carbon dioxide, and it is unlikely that one type of membrane can be used in each of the indicated sites. The basic locations of the membrane installation includes [5]:

1. After the shift reactor (Fig. 3a). This is the location at which currently CO₂ capture using absorption methods is carried out. Subjected to the separation synthesis gas is cleaned from all impurities. Current technologies require cooling of gas after exiting the shift reactor, what causes condensing of steam and reduces the efficiency of the system.
2. Between compression stages (Fig. 3b). The advantage of such location is the fact, that the high feed gas pressure increases the driving force for the transport of H₂ through the membrane. It maximizes the H₂ recovery or minimizes the surface of membrane. Additional benefits

may result from the use of sweep gas, which may be e.g. nitrogen from ASU. In this configuration, it is theoretically possible to capture 98% of H_2 [5]. Also, in such system the amount of energy required for CO_2 compression is minimized. Furthermore, hydrogen can be supplied to the gas turbine under sufficient pressure, without the need for its recompression. Such configuration, like the one described earlier, needs the purification of the gas before separation on the membrane.

3. Between degrees of the shift reactor (Fig. 3c). In this context, the reaction equilibrium is shifted toward the membrane separation of hydrogen. Membrane and catalyst of the shift reaction must be resistant to the presence of sulfur compounds in the gas (mainly H_2S). Such a placement of the membrane allows to minimize the amount of catalyst (and thus reducing the amount of shift reactors). In order to increase the effectiveness of the process it is required to provide steam for the producer gas and to reduce the use of interstage cooling. The use of high temperature gas cleaning would remove sulfur compounds before the membrane and the catalyst of shift reaction.
4. Between cooling stages (Fig. 3d). In this configuration, the reactions occur at elevated temperature. Such configuration causes, that membranes must have high tolerance to such impurities as sulfur compounds, nitrogen compounds or trace amounts of metals that are present in the gas from generator. Such location causes exploitation difficulties and puts the greatest requirements on the membrane.

Gas leaving the gasification reactor is at high pressure. After cleaning the raw gas from ashes, sulfur compounds and other pollutants, and after the shift process, resulting gas is directed to the separation process. The synthesis gas has still high pressure, in the range of 10–21 bar. This pressure is the driving force for membrane separation process. The pressure on the permeate side can also be reduced, what will affect the stream permeating through the membrane. This results from the equation [12]:

$$dJ_i = \frac{P_i}{\delta} (p_F X_i - p_P Y_i) dA_m . \quad (2)$$

Stream permeating through the membrane will thus depend on the coefficient of permeability of the component, the concentration of the component in the feed gas and permeate, and the thickness of the membrane, but also of the partial pressure difference of the permeating component.

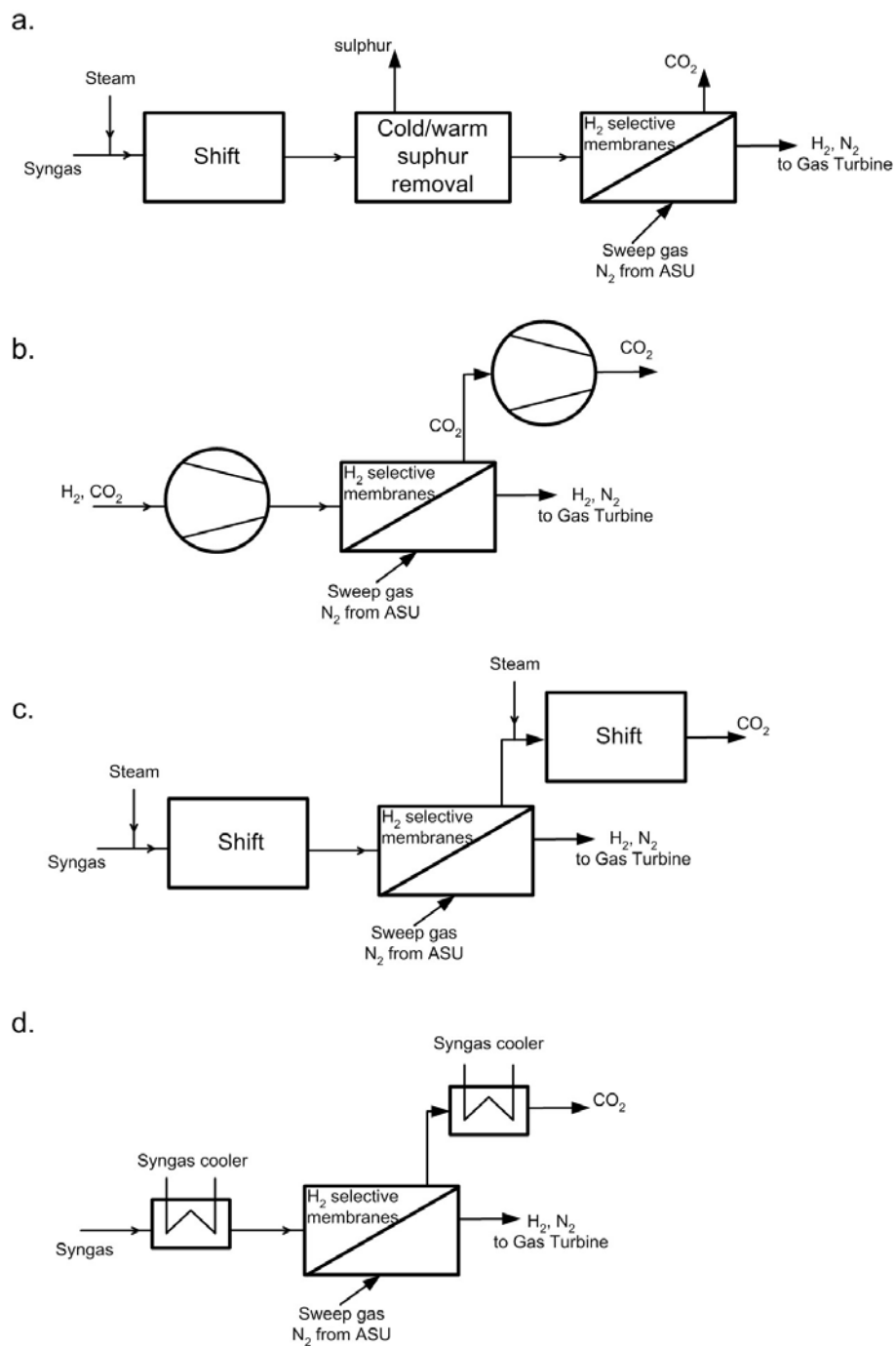

Figure 3. Integration of membrane in the IGCC systems [5].

Permeability coefficient depends mainly on the type of membrane material and the type of permeating gas component. If Eq. (2) is written separately for the two gaseous components such as CO₂ and H₂, the ratio of these elementary streams will be proportional to the ratio P_{CO_2}/P_{H_2} . This quantity is defined as the ideal selectivity coefficient:

$$\alpha^* = \frac{P_{CO_2}}{P_{H_2}}. \quad (3)$$

An important factor influencing the size of the gas stream that is penetrating through the membrane is also its thickness. Membrane thickness is limited by their mechanical strength to the pressure variations and their difference on both sides of the membrane, as well as technical difficulties in producing uniform polymer layer on the entire surface of the membrane. Achieving the membrane thickness equal to 2 μm is a realistic goal in the development of membrane technology.

For the evaluation of the CO₂ separation process from the exhaust gases two quantities are especially important:

- molar share of CO₂ in the permeate (permeate purity),
- carbon dioxide recovery ratio, specifying how much of carbon dioxide from flue gas or synthesis gas is present in the permeate flux, and expressed by the equation:

$$R = \frac{n_P (Y_{CO_2})_P}{n_F (X_{CO_2})_F}. \quad (4)$$

In the literature (e.g. [22]) it is shown, that the purity of the separated CO₂ should be in the range 0.8–0.95, and carbon dioxide recovery ratio should be greater than 0.9. The larger these ratios the lower the emission of carbon dioxide into the atmosphere. At the same time the costs associated with compression, transport and deposition (storage) of CO₂ are decreasing [23].

3 Description of separation models and results of calculations

Calculations of carbon dioxide capture process based on membrane gases separation were carried out with the use of Aspen software. Modeling of the separation process was based on several assumptions. The analysis was performed on the membrane module, of which the internal structure is made

from capillary tube of the cross flow. Flowing through the membrane module synthesis gas was treated as a semi-ideal gas. Furthermore, it was assumed, that the process proceeds in a constant temperature of 40 °C, which allowed for accepting for the analysis of fixed rates of gas permeability. The analysis also assumed, that the purity of separated carbon dioxide should be at the level of 95%. It was assumed, that through the module with variable area flows the synthesis gas composed of: CO₂ = 38.8%, H₂ = 50.4%, N₂ = 8.6% and CO = 2.2% [22], with the mole flow rate of 100 kmol/h. Decision variables of the process were synthesis gas pressure and permeate pressure. The pressure was changed within 21 bar $p_F \geq 10$ bar and 0.5 bar ≥ 1 bar p_p . This allowed for selection of such conditions of the process, for which the power demand for the process of separation of CO₂ was the smallest, thus a high degree of CO₂ recovery was maintained.

In IGCC systems synthesis gas is composed primarily of hydrogen and carbon monoxide (which, after the shift reaction turns into CO₂), so the membrane used in these systems is usually selective for hydrogen (H₂/CO₂ separation) or selective for carbon dioxide (CO₂/H₂). A process of separating hydrogen from synthesis gas before the shift process can also be carried out, then membranes for H₂/CO separation are applied. In such a case two streams of combustible gas are obtained, whereas the stream rich in CO should be combusted in oxygen in order to obtain exhaust gases consisting mainly of CO₂.

Two types of membranes were used in the study. The first selected for the process membranes are polymer membranes made from polyvinylamine FSC (fixed site carrier polyvinyleamine membrane), with the permeability coefficients for CO₂ equaled to 0.05 m³(STP)/(m²·h·bar) and hydrogen selectivity $\alpha^* = 100$ [1]. Others selected for the analyses membranes were composite ceramic membranes made from silica/alumina with the permeability of hydrogen at 0.9685 m³(STP)/(m²·h·bar) and carbon dioxide selectivity $\alpha^* = 1500$ [19]. These membranes have permeability coefficient for nitrogen equal to 0.0004 m³(STP)/(m²·h·bar). Selection of membranes was carried out in such a way, that one of the membranes were selective for carbon dioxide and the other for hydrogen. This means, that in the first case carbon dioxide is obtained at atmospheric pressure, while hydrogen is under high pressure. Whereas, the application of ceramic membranes allows to recover carbon dioxide under high pressure, which translates into lower power requirement for its subsequent compression in order to transport to a storage place.

The use of polymer membranes FSC with privileged transport of carbon dioxide allowed to achieve both high purity of separated CO_2 equal to 0.95 and high recovery rate within the limits $R = 0.74\text{--}0.91$ depending on the applied pressure. The effect of decision variables on the recovery ratio and membrane surface is shown in Fig. 4. Such conduction of the process also led to receiving a second stream (retentate) rich in hydrogen. Retentate stream was composed of more than 70% (depending on the pressure in the permeate even 77%) of hydrogen at the level of hydrogen recovery rate above 97%.

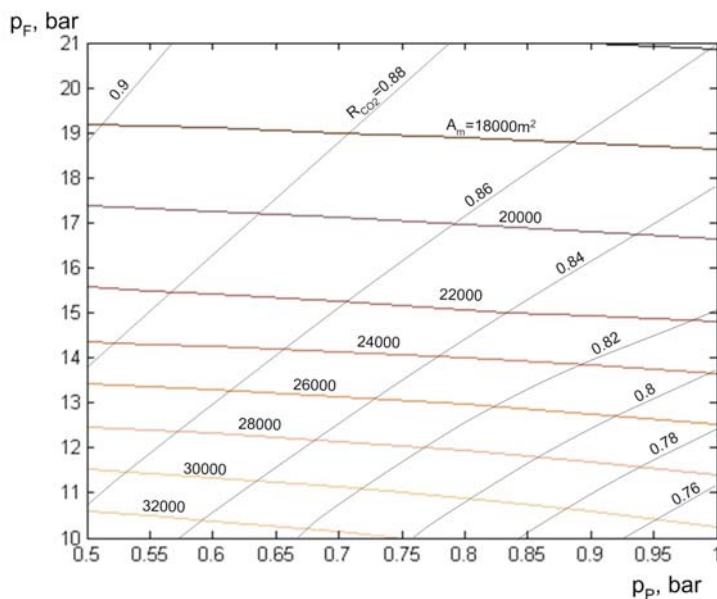

Figure 4. The influence of the synthesis gas and permeate pressure on the CO_2 recovery ratio and the membrane surface for polymeric membrane FSC selective for carbon dioxide.

In turn, the application of ceramic membranes with active silica/alumina layer with privileged transport of hydrogen led to the achievement of permeate of a very high purity (over 90% of hydrogen), while the recovery rate was at 97%. However, the purity of separated CO_2 for these membranes did not achieve the assumed level of 95%. According to the calculations the highest possible purity of carbon dioxide equal to 76%. Other components of the retentate stream was primarily nitrogen ($\text{N}_2 = 0.172$), carbon monoxide (0.045), and the rest was hydrogen. The carbon dioxide recovery ratio in this case is very high, within the range 91–99%. In order to obtain

high purity and recovery ratio of permeate the use of a vacuum pump is not needed. The decrease of pressure on the permeate side slightly improves hydrogen recovery ratio, but in the same time the purity of hydrogen is decreasing, what causes that the power need for vacuum pump is considerably increasing. High pressure of syngas allows for minimizing of the required membrane area for one module in order to maintain both, high recovery ratio and permeate purity.

For permeate collected at ambient pressure and for feed pressure over $p_F = 17$ bar the required membrane surface area is up to 10 000 m², while when synthesis gas pressure decreases, the surface area of membrane is rapidly growing. For example, for pressure $p_F = 10$ bar, the surface of the membrane increases to over 100 000 m². The results of the analysis on the influence of the feed and permeate pressure on the desired membrane surface and the purity and hydrogen recovery ratio is shown in Fig. 5.

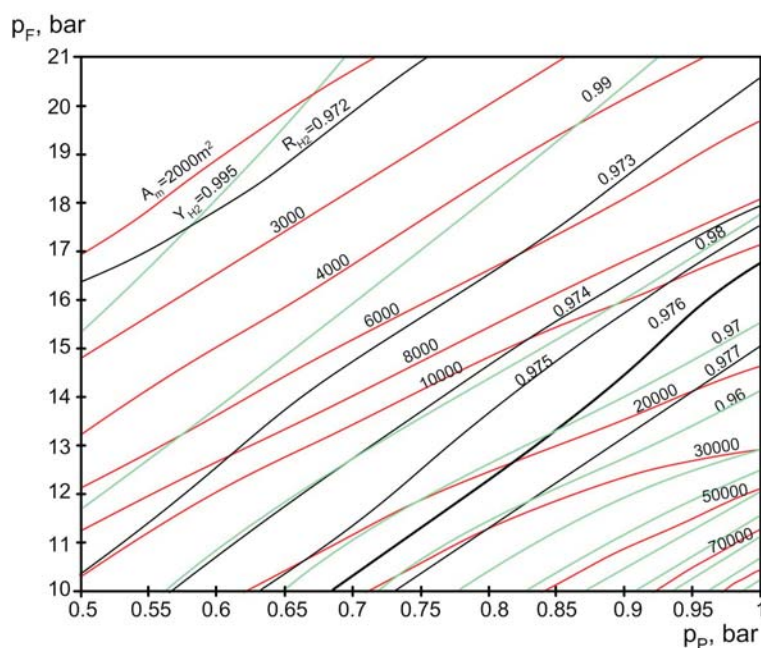

Figure 5. Influence of the synthesis gas and permeate pressure on the recovery ratio and hydrogen purity, and on surface area of the membrane for ceramic silica/alumina membranes selective for hydrogen.

Apart from purity and carbon dioxide recovery ratio, an important issue in the selection of membranes is the electricity demand for conducting

a separation process. Consumption of electricity in a carbon dioxide capture plant increases the plant's auxiliary power and thereby reduces the efficiency of the entire system. Reducing of pressure on the permeate side is connected with energy inputs on the vacuum pump. Electric power is also needed for compressors of separated CO₂ as well as for the compressor that will prepare hydrogen for combusting in gas turbine.

It was assumed, that hydrogen pressure should be equal to 21 bar, while compression of CO₂ needs 2 compressor (with the same compression ratio) to achieve desired pressure equal to 150 bar. Between compression stages heat exchangers are used in order to cool the gas before further compression. The temperature of gas, both before and after compressors and vacuum pumps, as well as already compressed CO₂ was maintained at 40 °C.

Giving consideration to all these assumptions, the power demand for CCS installation will be equal to:

$$N_{el,CCS} = N_{el,VP} + N_{el,C} + N_{el,C1} + N_{el,C2} . \quad (5)$$

Scheme of the CCS installation with membrane module (M), vacuum pump (VP), compressors (C, C1, C2) and heat exchangers for polymer membrane is shown in Fig. 6, while in Fig. 7 a scheme of the installation with ceramic membranes is presented.

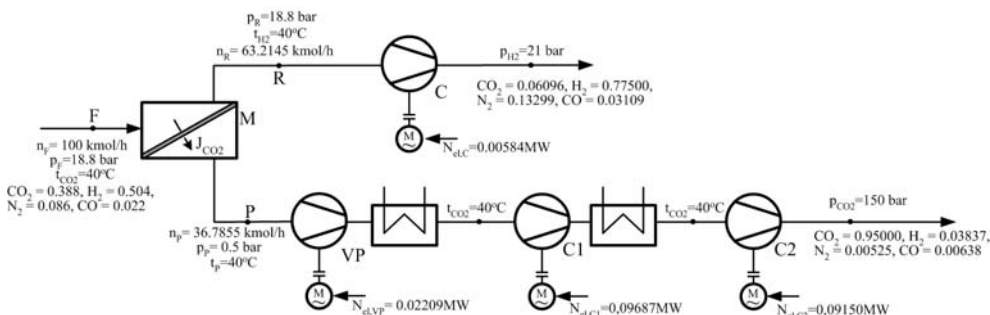

Figure 6. Scheme and parameters of the separation process for polymer membranes FSC selective for carbon dioxide.

From the analysis of Fig. 6 it results, that for polymer membranes FSC, CO₂ stream of permeate rich in carbon dioxide and retentate stream can be obtained. Permeate stream containing 95% of CO₂ (the rest consists of hydrogen 3.83%, carbon monoxide 0.64% and nitrogen 0.53%) is collected under the pressure 0.5 bar, generated by a vacuum pump, and then is compressed by compressors C1 and C2 to the pressure 150 bar. The pressure

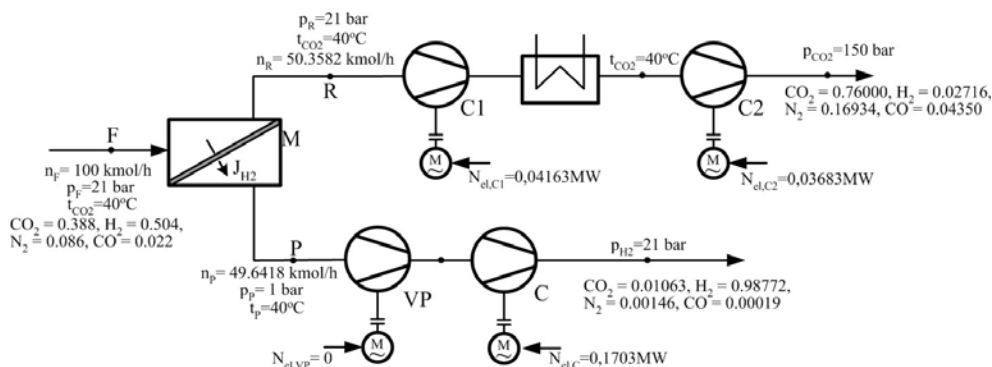

Figure 7. Scheme and parameters of the separation process for ceramic silica/alumina membranes selective for hydrogen.

after membrane equals to 50 kPa assures high recovery ratio of carbon dioxide, at the level of 90%. Retentate, collected under high pressure, is fuel stream for gas turbine. It consists of hydrogen of the share 77.5%, nitrogen 13.3%, carbon dioxide 6.1% and carbon monoxide 3.1%. The power demand for CCS installation with the assumption, that for the stream of gas 100 kmol/h (gas obtained from generator after shift process and purification – point A in Fig. 1) was calculated and equals to $N_{el,CCS} = 0.2163$ MW for synthesis gas pressure 18.8 bar. The power demand depends mainly on the power need for carbon dioxide compressors (C1,C2), that have to assure required pressure for gas turbine system. Whereas, while the separation process proceeds under feed pressure at 21 bar – compression of the gas supplied to the gas turbine is not needed, but only the use of vacuum pump and CO₂ compressor in the CCS installation. In this case the overall power need for the process is equal to 0.2065 MW (vacuum pump generating pressure of 56 kPa, what will assure recovery ratio 90% and purity 95%).

From the analysis of Fig. 7 it results, that when using ceramic membranes the permeating stream is rich in H₂. In this case, a compressor must be used in order to compress separated H₂ to the pressure 21 bar. Permeate stream is collected in ambient pressure (there is no power need for a vacuum pump). The purity of this stream for hydrogen equals to 98.78%, the rest consists of CO₂ = 1.06%, N₂ = 0.15 and CO = 0.02%, and hydrogen recovery ratio is equal to 97%. Remaining under high pressure retentate consists in 76% of CO₂ with recovery ratio 95%, the rest contains nitrogen 16.9%, carbon monoxide (4.4%) and hydrogen (2.7%). This stream requires

significantly lower energy input to compress it to the pressure 150 bar. Total energy requirements for CCS installation $N_{el,CCS} = 0.2488$ MW. Membranes used in carbon dioxide capture processes should in higher degree permeate nitrogen, so that in the permeate stream was mixture of hydrogen and nitrogen. It will allow to increase the purity of CO_2 in the stream designated for storage.

Energy consumption in the separation process for the membranes used in analysis is at the same level, thus, the main factor that will decide about the selection of proper membrane will be the purity of the received gases. When high purity carbon dioxide is needed (around 95%), polymer membranes should be used, while when hydrogen is needed at high purity, ceramic membranes would be employed.

4 Summary and conclusions

Carbon dioxide capture and storage is considered as one of the main potential for reducing of emissions to the atmosphere within the next 40 years [17], besides e.g. increased use of renewable energy sources or increased efficiency of systems. Although none of the existing IGCC system recover CO_2 from the process, this technology is considered to be the best prepared for implementation. At the same time the obligation to capture and storage CO_2 will cause, that the IGCC systems will be able to compete in terms of investments with conventional systems [18]. Implementation of CCS installations is not only connected with additional investment costs, but also with energetic cost (increase of the power plant auxiliary power and thus, efficiency decrease).

Selection of an appropriate membrane requires the selection of membrane itself (type, size and other parameters) and its location in the system. It is also important to determine, for which gases it should be selective (hydrogen, carbon monoxide or carbon dioxide). The choice of membranes is very important, due to the fact, that it is associated with certain consequences, including purity of separated CO_2 , the recovery ratio or the surface of the membrane (investment costs). When using membranes selective for carbon dioxide, permeate can be obtained at high purity and recovery rate, however, CO_2 is recovered at low pressure, what increases the power need for compression it to the proper for transport pressure. The main advantage of using of membranes selective for hydrogen is receiving of hydrogen at relatively high pressure, what decreases the energy requirements for its

compression. However, in this case, it is difficult to obtain high-purity gas. Collected CO₂ stream at high pressure allows for receiving of the purity at the level of 76%. Obtained in this case purity is not sufficient for capturing process, thus, it is needed to apply additional installation (e.g. another membrane module), which will allow for increasing of the share of carbon dioxide in separated stream. An alternative to these solutions may be the use of membranes CO/H₂ type, which may allow for eliminating of the shift reactor (conversion of carbon monoxide to carbon dioxide). In this case captured CO is an additional fuel, but which should be combusted in pure oxygen, in order to obtain mainly CO₂ as a product. Production of high purity oxygen is associated with high investment and exploitation cost, however, in the IGCC systems oxygen is usually produced for gasification purposes, what can limit additional energy input.

Membrane separation has the advantages that make it a future-proof technology in the context of CO₂ capture. Studies show, that the membrane can compete in terms of cost and energy demand with absorption processes, or cryogenic separation, while causing smaller efficiency loss of the entire system. Membrane separation is still less attractive than physical absorption processes based on Selexol technology (especially in terms of purity of separated CO₂ [11]). Hence, the research, among others, on the selection of the appropriate type of membrane, membrane integration in the IGCC system and optimization of the entire process is needed.

Acknowledgments Presented investigations have been carried out within the frame of the research project No. 3605/B/T02/2009/37, financed by the Ministry of Education and Science.

Received 15 June 2010

References

- [1] GRAINGER D., HAGG M.B.: *Techno-economic evaluation of a PVAm CO₂-selective membrane in an IGCC power plant with CO₂ capture*. Fuel **87** (2008), 14–24.
- [2] PESIRI D., JORGENSEN B., DYE R.: *Thermal optimization of polybenzimidazole meniscus membranes for the separation of hydrogen, methane, a carbon dioxide*. Journal of Membrane Science **218** (2003), 11–18.
- [3] SKOREK-OSIKOWSKA A., KOTOWICZ J.: *Purification technologies in the integrated gasification combined cycle (IGCC) installations — review and outlook*. Power engineering and environment 2009. Ostrava, 7–8 September 2009, 67–72.

- [4] ŚCIAŹKO M., CHMIELNIAK T.: *The principles of operation and constructions of generators for coal gasification for IGCC systems*. Conference on Development Strategies for Energy Conversion Machinery and Systems in Power Engineering. The Energy Problems Committee of the Polish Academy of Sciences & The Institute of Power Engineering and Turbomachinery of the Silesian University of Technology, Gliwice 2009 (in Polish).
- [5] MARANO J., CIFERINO J.: *Integration of gas separation membranes with IGCC identifying the right membrane for the right Job*. Energy Procedia **1** (2008), 361–368.
- [6] THAMBIMUTHU K.V.: *Gas cleaning for advanced coal-based power generation*. IEACR/53. March 1993. IEA Coal Research, London.
- [7] IPCC: *IPCC Special Report on Carbon Dioxide Capture and Storage*. Prepared by Working Group III of the Intergovernmental Panel on Climate Change, B Metz, *et al.* (eds.). Cambridge University Press, Cambridge – New York 2005, 442.
- [8] MAURSTAD O.: *An overview of coal based Integrated Gasification Combined Cycle (IGCC) Technology*. September 2005. MIT LFEE 2005-002 WP.
- [9] RATAFIA-BROWN J. *et al.*: *Major Environmental aspects of gasification-based power generation technologies*. National Energy Technology Laboratory U.S. Department of Energy. December 2002.
- [10] KANNICHE M., GROS-BONNIVARD R. *et al.*: *Pre-combustion, post-combustion and oxy-combustion in thermal power plant for CO₂ capture*. Applied Thermal Engineering, 2009.
- [11] KALDIS S.P., SKODRAS G., SAKELLAROPOULOS G.P.: *Energy and capital cost analysis of CO₂ capture in coal IGCC processes via gas separation membranes*. Fuel Processing Technology **85** (2004) 337–346.
- [12] BODZEK M., BOHDZIEWICZ J., KONIECZNY K.: *Membranes Technologies in Environmental Protection*. Wydawnictwo Politechniki Śląskiej, Gliwice 1997 (in Polish).
- [13] *Gasification World Database2007 — Current Industry Status. Robust Growth Forecast*. Department of Energy USA, National Energy Technology Laboratory, October. 2007. www.netl.doe.gov
- [14] KOTOWICZ J., JANUSZ K.: *The Basis of the membrane gases separation*. Rynek Energii **73** (2007)6, 29–35 (in Polish).
- [15] KRISHNAN G., STEELE D., O'BRIEN K., *et al.*: *Simulation of a process to capture CO₂ from IGCC syngas using a high temperature PBI membrane*. Energy Procedia **1** (2009), 4080–4088.
- [16] REZVANI S., HUANG Y., MCILVEEN-WRIGHT D., *et al.*: *Comparative assessment of coal fired IGCC systems with CO₂ capture using physical absorption, membrane reactors and chemical looping*. Fuel **88** (2009), 2463–2472.
- [17] *Carbon Capture and Storage: Meeting the Financing Challenge*. Presentation to: Workshop on Carbon Capture and Storage Financing Challenges and Opportunities. London, September 2008.
- [18] KALDIS S.P., SKODRAS G., SAKELLAROPOULOS G.P.: *Energy and capital cost analysis of CO₂ capture in coal IGCC processes via gas separation membranes*. Fuel Processing Technology **85**(2004), 337–346.

-
- [19] LEE D., ZHANG L., OYAMA S., NIU S., SARAF R.: *Synthesis, characterization, and gas permeation properties of a hydrogen permeable silica membrane supported on porous alumina*. Journal of Membrane Science **231** (2004), 117–126.
- [20] BEDNARSKA A.: *European plans for improvement of the energy efficiency*. Web sites of URE: www.ure.gov.pl, 2008 (in Polish).
- [21] *Directive of the European Parliament and the Council 2009/29/WE of 23 April 2009 amending directive 2003/87/WE in order to improve and extend the European system of greenhouse gas emission allowances trade*. Official Journal of the European Union, L 140/63.
- [22] DAVIDSON J, THAMBIMUTHU K.: *Technologies for capture of carbon dioxide*. Proceedings of the Seventh Greenhouse Gas Technology Conference, Vancouver, International Energy Association (IEA), Greenhouse Gas R&D Programme, 2004.
- [23] KOTOWICZ J., CHMIELNIAK T., JANUSZ-SZYMAŃSKA K.: *The influence of membrane CO₂ separation on the efficiency of a coal-fired power plant*. Energy **35** (2010), 841–850.